



INSTRUCTIONS

-J05999

REV. 2014-02-06

FOUR-POINT DETACHABLE DOCKING HARDWARE KIT

GENERAL

Kit Number

52300353, 52300354

Models

For model fitment information, see the P&A retail catalog or the Parts and Accessories section of www.harley-davidson.com (English only).

Installation Requirements

Separate purchase of other parts or accessories are required for proper installation of this kit on certain model motorcycles. See the P&A retail catalog or the Parts and Accessories section of www.harley-davidson.com (English only) for a list of required parts or accessories for a specific model.

Loctite® 262 Threadlocker and Sealant - Red (Part No. 94759-99) **and** Loctite 243 Medium Strength Threadlocker and Sealant - Blue (Part No. 99642-97) **are** required for proper installation of this kit.

WARNING

The rider's safety depends upon the correct installation of this kit. Use the appropriate service manual procedures. If the procedure is not within your capabilities or you do not have the correct tools, have a Harley-Davidson dealer perform the installation. Improper installation of this kit could result in death or serious injury. (00333a)

NOTE

This instruction sheet refers to service manual information. A service manual for this year/model motorcycle is required for this installation. One is available from a Harley-Davidson dealer.

Kit Contents

See Figure 2 and Table 1.

PREPARATION

WARNING

To prevent accidental vehicle start-up, which could cause death or serious injury, remove main fuse before proceeding. (00251b)

NOTE

- **WITH security siren:** With security fob present, turn ignition switch ON. After system is disarmed, turn ignition switch OFF. **IMMEDIATELY** remove the main fuse per the service manual.
- **WITHOUT security siren:** See the service manual to remove the main fuse.

INSTALLATION

Install Docking Brackets

1. See the service manual to remove the saddlebags.
2. See Figure 2. Remove two screws (B) from the saddlebag support on each side. Lift the slot cover inserts (A) from the slots in the supports.

NOTE

The docking plates are side-specific. The longer pin (C) mounts toward the front of the vehicle.

3. Insert each **new** docking plate assembly (1 or 2) into the slot in the correct-side saddlebag support.
4. Place a washer (8) over the threads of each of the **larger** screws (7) from the kit. Apply 2 or 3 drops of Loctite 262 Threadlocker and Sealant - Red to the screw threads.
5. Install the screws through the docking plates (1 or 2) and saddlebag supports, and into the frame extension threaded holes on each side. Tighten to 20 ft-lbs (27 Nm).

NOTES

See Figure 1.

- Install the docking points (1) to the docking plates (5) with the thicker flange (2) facing inward.
- The black plastic docking point insert is elliptical, with two notches 180 degrees apart indicating the largest diameter. With notches horizontal (3), docking point fit is loosest. With notches vertical (4), docking point fit is tightest.

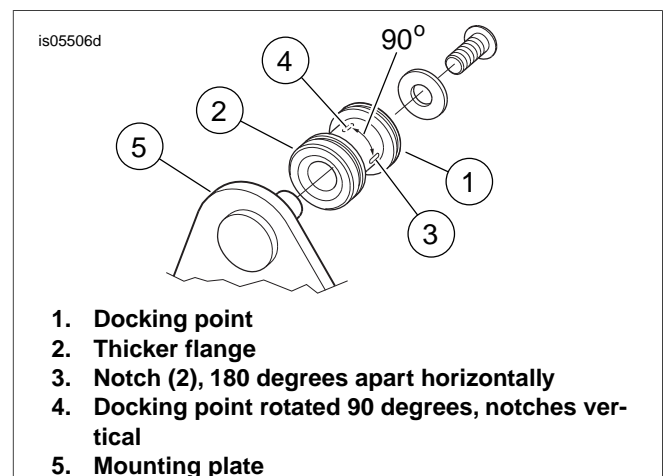

Figure 1. Docking Point Installation

6. See Figure 2. Slide a spacer (3) onto the longer pin (C) of each docking plate. Slide a docking point (4), **thicker** flange first, onto each docking plate pin.

7. Install the screws (6) into the docking plate pins. Rotate each docking point to position the notches horizontally (Figure 1, item 3). Tighten the screws until snug.

Check Docking Point Alignment and Tightness

8. Install a detachable accessory per the instructions in **that** kit.

If the docking points are spaced too wide:

- a. Remove the accessory.
- b. See Figure 2. Remove screw (6) and docking point (4) from all four docking point pins.
- c. Install docking point (**thinner** flange first) onto each docking plate pin.
- d. Apply 2 or 3 drops of Loctite 243 - Blue to the threads of each screw (6). Install screws. Rotate each docking point to position the insert notches horizontally (Figure 1, item 3). Tighten screws until snug.

If the docking points are spaced too narrow:

- a. Remove the accessory.
 - b. See Figure 2. Remove screw (6), docking point (4) and spacer (3) (if installed) from all four docking point pins.
 - c. Install washers (5) to each docking point. Install spacer and docking point (**thicker** flange first) to each docking point pin.
 - d. Apply 2 or 3 drops of Loctite 243 - Blue to the threads of each screw (6). Install screws. Rotate each docking point to position the insert notches horizontally (Figure 1, item 3). Tighten screws until snug.
9. Install the detachable accessory per instructions.
If the accessory does not attach tightly to the docking points,
 - a. Loosen the screws.
 - b. See Figure 1. Rotate the docking points (1) slightly away from horizontal until a tight fit is achieved at each location.

Complete Docking Bracket Installation

10. See Figure 2. Tighten the docking plate pin screws (6) to 10.5 ft-lbs (14.2 Nm).

11. See the service manual to install the saddlebags.

COMPLETION

NOTE

*To prevent possible damage to the sound system, verify that the ignition is OFF **before** installing the main fuse.*

1. See the service manual to install the main fuse.

MAINTENANCE

In time docking points wear, causing the installed detachable accessory to become loose and rattle. Tighten the fit using the following method.

1. See Figure 2. Record the current notch position for each docking point. Remove the screw (6) from all four docking point pins.
2. Remove threadlocker from the docking point screws and mounting hole threads before applying Loctite 243 - Blue to the screw threads. Install the docking points, screws and washers. Tighten finger-tight.
3. If the notches **are not** in vertical position (F), rotate the docking points slightly, moving the notches toward (F) until a tight fit of the detachable accessory is achieved at each location.
4. Tighten the docking point screws to 10.5 ft-lbs (14.2 Nm).
5. If the docking point insert notches **are** in vertical position (F):
 - a. Remove the screw (6) from all four docking point pins.
 - b. Rotate each docking point until the **second** notch reaches position (E).
 - c. Remove threadlocker from the docking point screws and mounting hole threads before applying Loctite 243 - Blue to the screw threads. Install the screws and washers. Tighten finger-tight.
 - d. Check the detachable accessory at each docking point, rotating the notch toward (F) until a tight fit of the detachable accessory is achieved at each location. Tighten the screws to 10.5 ft-lbs (14.2 Nm).
6. After multiple adjustments, if the detachable accessory continues to rattle or remains loose, replace the docking points.

SERVICE PARTS

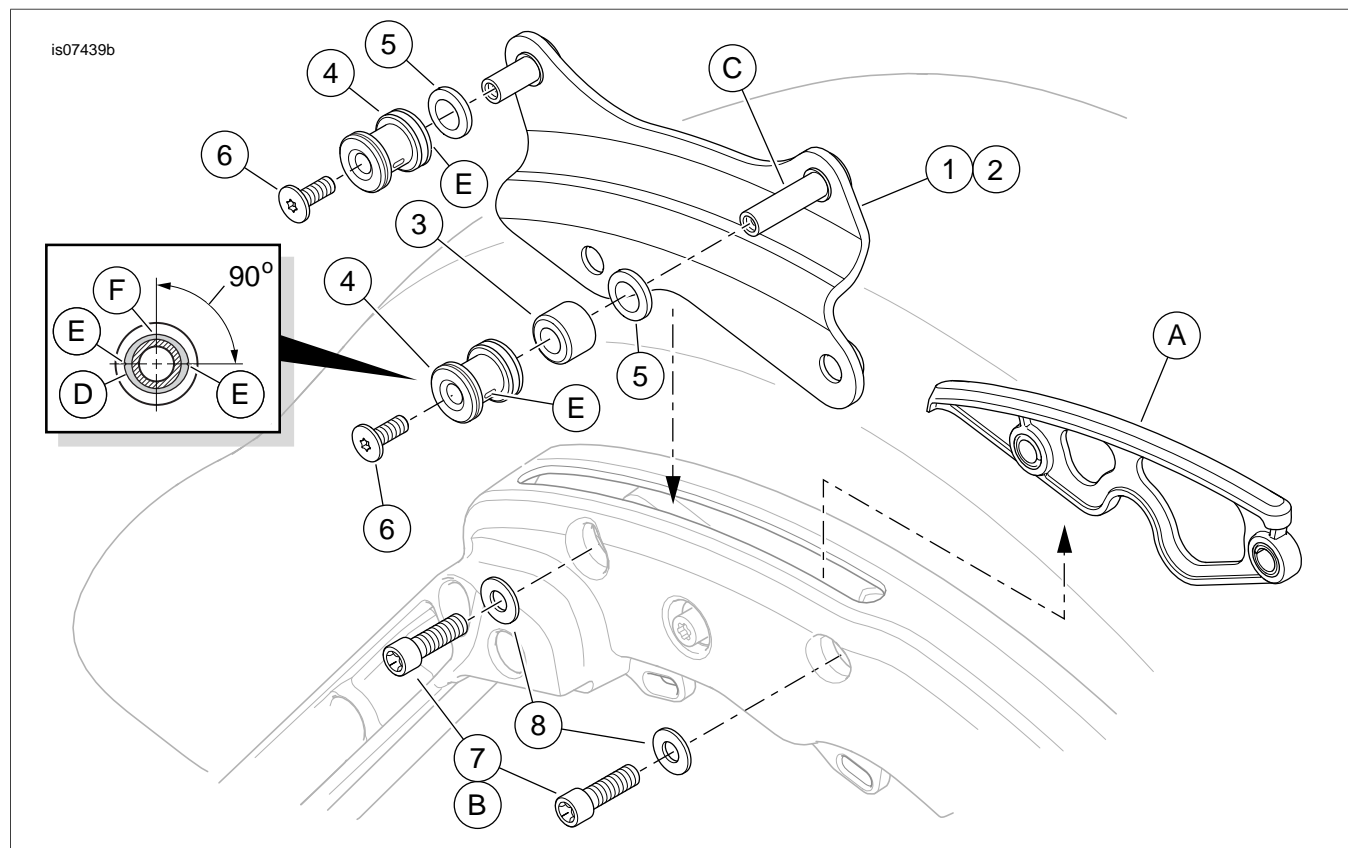

Figure 2. Service Parts, Four-Point Detachable Docking Hardware Kit

Table 1. Service Parts

Item	Description (Quantity)	Part Number
1	Docking plate assembly, chrome (right side, shown)	52300348
	Docking plate assembly, black (right side, shown)	52300355
2	Docking plate assembly, chrome (left side, not shown)	52300349
	Docking plate assembly, black (left side, not shown)	52300356
3	Spacer, docking point (2)	12400059
4	Docking point (4)	52300345
5	Plain washer, chrome (4)	10300079
6	Cap screw, flat head TORX, 1/4-20 x 5/8 in (16 mm) long (4)	10200322
7	Cap screw, TORX head, 5/16-18 x one in (25 mm) long (4)	10200157
8	Plain washer, zinc finish (4)	6302
Items mentioned in text:		
A	OE slot cover insert (2)	
B	Slot cover insert attaching screw (4)	
C	Long docking plate pin (2)	
D	Docking point plastic insert (elliptical shape exaggerated for clarity)	
E	Notch in plastic insert (2)	
F	90 degree maximum docking point adjustment range (x2)	