

SERVICE BULLETIN



M-1324

May 16, 2012

DYNA MODEL MOTORCYCLE VIBRATION

Purpose

The purpose of this bulletin is to educate the technician on the best method for resolving excessive vibration on Dyna model motorcycles. The Dyna Glide engine isolator function can be impaired by insufficient front engine isolator top radius clearance and mount misalignment. The purpose of this procedure is to create more clearance in the isolator system and improve the isolator performance.

NOTES

- *The Dyna engine isolators will stretch over time. For this reason, replacing the isolator may not provide the best results as the existing mount has already stretched.*
- *The Dyna engine isolator system does not eliminate all vibration. These procedures are intended to address vibration characteristics which are in excess of typical Dyna model motorcycles.*

Vehicles Affected

All 1990 and later Dyna model motorcycles.

Markets Affected

This bulletin affects all markets.

Required Dealer Action

1. Verify the severity of the vibration.
2. If vehicle has a severe vibration, inspect frame, front fork and rear fork for damage before proceeding.

NOTES

- **FLD only:** See Figure 1. Verify the exhaust isolator, located in the muffler support bar, is not distorted by over-tightening and inspect the support bar. Replace muffler support bar if clearance between pin with flange nut (1) and muffler support bar (3) is less than 0.100 in (2.54 mm).
 - *Inspect for any added accessories or vehicle modifications. Some aftermarket accessories can negatively affect vibration levels.*
3. Check rear belt tension. Adjust if necessary.
 4. Verify the shock and front fork damping adjustments, if equipped. If the suspension is not correct, adjust as necessary. See the service manual.

5. Check the torque on the following fasteners:
 - a. Verify the stabilizer link fasteners are tightened to 18-22 ft-lbs (24.4- 29.8 Nm).
 - b. Verify the two cylinder head bracket fasteners are tightened to 35-40 ft-lbs (47.5-54.2 Nm).
 - c. **FLD, FXDF and FXDWG models:** Verify the exhaust support bracket to transmission case fasteners are tightened to 17-21 ft-lb (23.0-28.4 Nm).

NOTE

Removal of jiffy stand pivot block pin is easier when front engine isolator is removed.

6. Verify jiffy stand pivot block pin is oriented so head of pin is near crankcase bolt head. If it is not, remove pin and rotate as necessary.
7. Leave the powertrain and the chassis unsupported so that the weight of the powertrain is hanging freely from the chassis.
8. See Figure 2. Use a feeler gauge (3) to measure clearance between front engine isolator top radius (2), located on top of the front engine isolator (1), and front engine bracket (4).
9. You can obtain additional clearance as follows:
 - a. Loosen front engine bracket fasteners to the front engine isolator.
 - b. Using a suitable device, raise powertrain slightly to limits of bracket holes.
 - c. Tighten fasteners to 22-27 ft-lbs (29.8-36.6 Nm).
10. If the clearance is not 0.020-0.040 in (0.508-1.016 mm), remove and modify the front engine isolator to create sufficient clearance.

NOTE

In the interest of preserving customer safety and satisfaction, always check for outstanding recalls whenever any motorcycle is brought into your dealership for either maintenance or service.

| ROUTING | SERVICE MANAGER | SALES MANAGER | PARTS MANAGER | WARRANTY PROCESS MANAGER | LEAD TECHNICIAN | TECHNICIAN NO. 1 | TECHNICIAN NO. 2 | TECHNICIAN NO. 3 | RETURN THIS TO |
|--------------|-----------------|---------------|---------------|--------------------------|-----------------|------------------|------------------|------------------|----------------|
| INITIAL HERE | | | | | | | | | |

©2012 H-D

11. See Figure 2. The required clearance can be added by removing a small amount of material from the front engine isolator top radius.
 - a. If the clearance was zero, remove 0.045 in (1.143 mm) from top of front engine isolator top radius to obtain clearance.
 - b. Measure the height of the mount and record the value.
 - c. Subtract the amount of clearance needed from the height to get the desired clearance.
 - d. Remove front engine isolator.
 - e. Place the engine isolator in a vise and use a file for best results.
12. Install the front engine isolator, Repeat the measurement process.
 - a. Tighten the front engine isolator to the proper specification and allow the powertrain to relax in the chassis for a few minutes.
 - b. If the clearance is not 0.020-0.040 in (0.508-1.016 mm), remove front isolator again and modify to create sufficient clearance.
13. Align front and rear engine isolators:
 - a. Using a suitable lifting device, raise rear wheel off floor. Lift under frame only. Do not place lifting device under powertrain.
 - b. Loosen fasteners securing front and rear isolators to frame mounts, 2-3 turns.
 - c. Start engine and run 15-30 seconds.
 - d. Beginning with front engine isolator, tighten front and rear engine isolator fasteners. Tighten to 22-27 ft lbs (29.8-36.6 Nm).
14. Using an inclinometer, verify that both front and rear brake discs are in alignment with each other. See service manual.
15. Test ride vehicle to assess vibration level.

NOTES

- Remove the mount and install promptly back in the chassis and attach to the powertrain so that the mount does not recover to an original un-stretched (relaxed) state.
- **IMPORTANT!** Excessive clearance will negatively impact chassis performance. Do not exceed 0.040 in (1.016 mm) clearance.

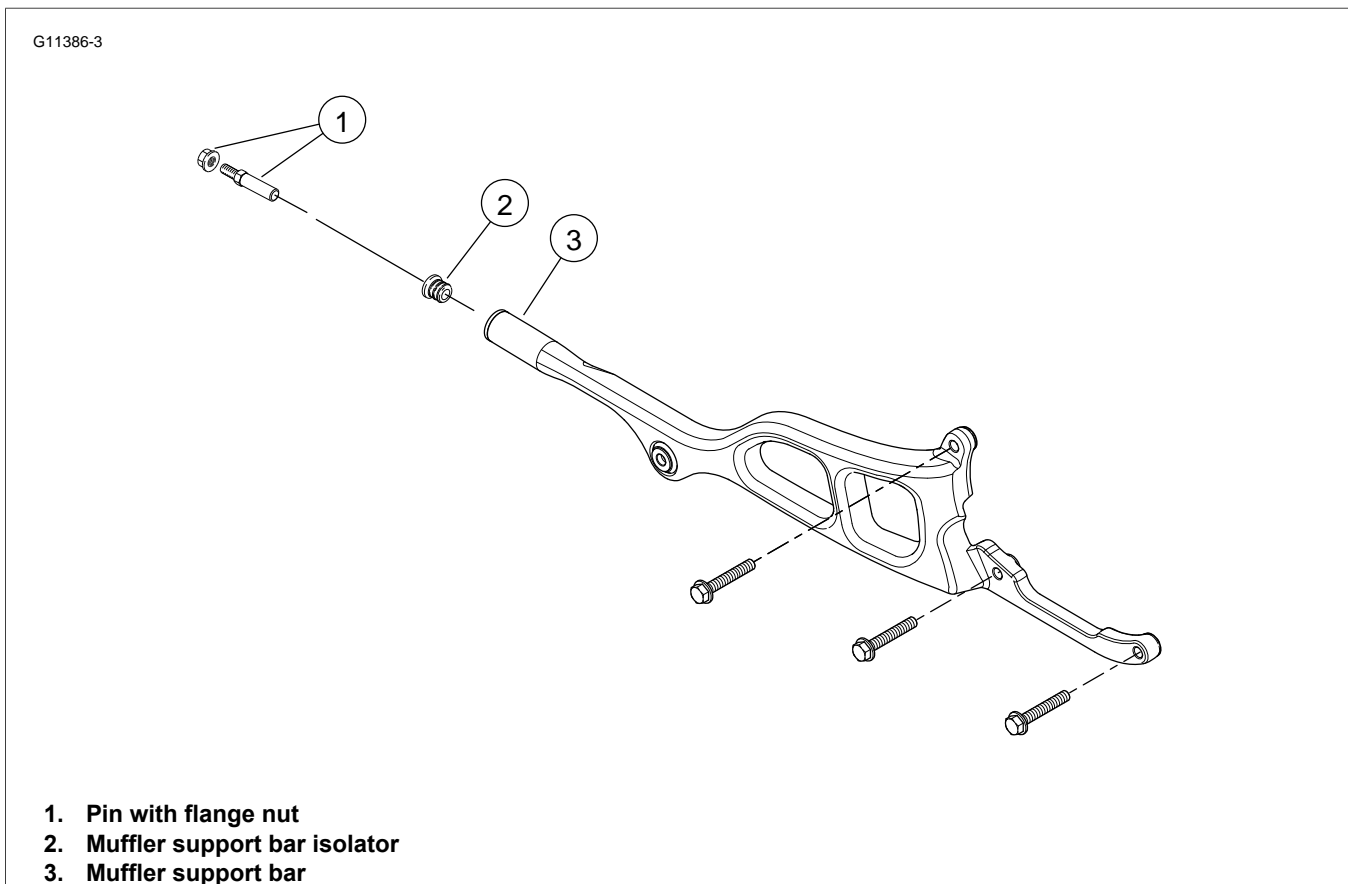
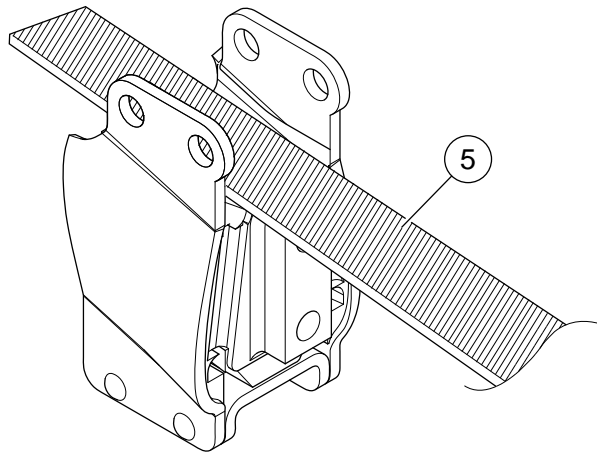
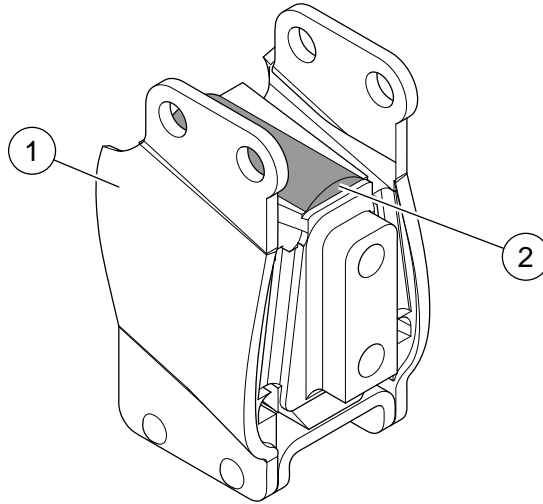
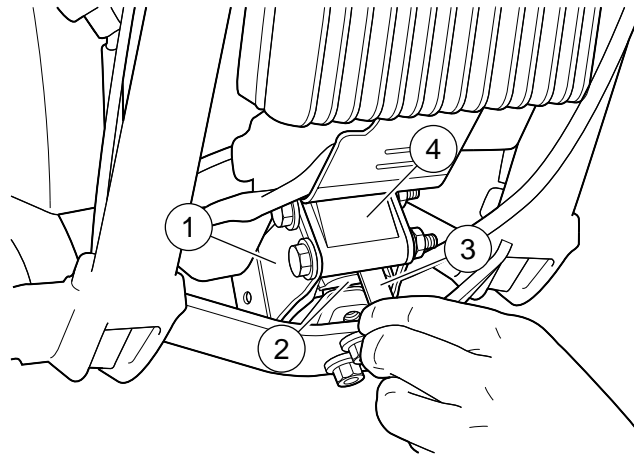

Figure 1. Muffler Support Bar Isolator Assembly



- 1. Front engine isolator
- 2. Front engine isolator top radius
- 3. Feeler gauge

- 4. Front engine mount bracket
- 5. File

Figure 2. Checking the Clearance of Front Isolator