



INSTRUCTIONS

-J04441

REV. 2009-06-26

AUTOMATIC COMPRESSION RELEASE OVERLAY HARNESS

GENERAL

Kit Number

70623-08

This harness is a component of Screamin' Eagle 110 cubic inch (1800 cc) Engine Conversion kits. Refer to those kits for fitment information.

Models

For model fitment information, see the P&A Retail Catalog or the Parts and Accessories section of www.harley-davidson.com (English only).

WARNING

The rider's safety depends upon the correct installation of this kit. Use the appropriate service manual procedures. If the procedure is not within your capabilities or you do not have the correct tools, have a Harley-Davidson dealer perform the installation. Improper installation of this kit could result in death or serious injury. (00333a)

NOTE

This instruction sheet references service manual information. A service manual for your model motorcycle is required for this installation and is available from a Harley-Davidson dealer.

Additional Parts Required

Separate purchase of a Micro Pack 64[®] Terminal Remover (HD-45928) is required for installation of this kit.

WARNING

The rider's safety depends upon the correct installation of this kit. Use the appropriate service manual procedures. If the procedure is not within your capabilities or you do not have the correct tools, have a Harley-Davidson dealer perform the installation. Improper installation of this kit could result in death or serious injury. (00333a)

NOTE

A service manual for your model motorcycle is available from your Harley-Davidson dealer.

Kit Contents

See Figure 6 and Table 1.

REMOVAL

Prepare for Service

NOTES

Complete these steps if this is a replacement to an existing ACR Overlay Wire Harness Kit. Otherwise, proceed with the INSTALLATION section.

If vehicle is equipped with Harley-Davidson Smart Security System, see owner's manual for instructions to disarm the system.

1. Position motorcycle on a suitable lift following the instructions in the service manual.
2. Remove seat according to the instructions in the service manual.
3. Refer to service manual to remove left saddlebag and side cover.

WARNING

To prevent accidental vehicle start-up, which could cause death or serious injury, disconnect negative (-) battery cable before proceeding. (00048a)

4. Disconnect battery cables, negative (-) battery cable first.

WARNING

When servicing the fuel system, do not smoke or allow open flame or sparks in the vicinity. Gasoline is extremely flammable and highly explosive, which could result in death or serious injury. (00330a)

5. Remove fuel tank according to the instructions in the service manual.

Removing Terminal Wires from Fuse Blocks

1. Refer to the service manual for wire terminal removal procedures.

INSTALLATION

Remove Electrical Components

1. *Replacement Only:* Separate ACR front and rear connectors from the ACR assemblies on the cylinder heads.
2. See Figure 1. Remove electronic control module (ECM) assembly (1) from caddy located under seat area.
3. See Figure 2. Disconnect ECM harness connector (3) by pushing on tab (1) and rotating lock (2) clockwise.



1. ECM
2. ECM harness connector

Figure 1. Electronic Control Module (ECM)



1. Tab
2. Lock
3. ECM harness connector

Figure 2. ECM Harness Connector Lock

4. Remove ECM caddy and battery from motorcycle.
5. Remove fuse block caddy mounting screws.
6. Remove battery box front mounting screw.
7. Lift battery box slightly to allow disengagement of fuse block caddy/battery box interlock.
8. Remove fuse block from caddy. Cut and remove cable straps as necessary.
9. See Figure 3. Remove cover from main wire harness trough on the frame backbone. Cut cable straps as necessary.

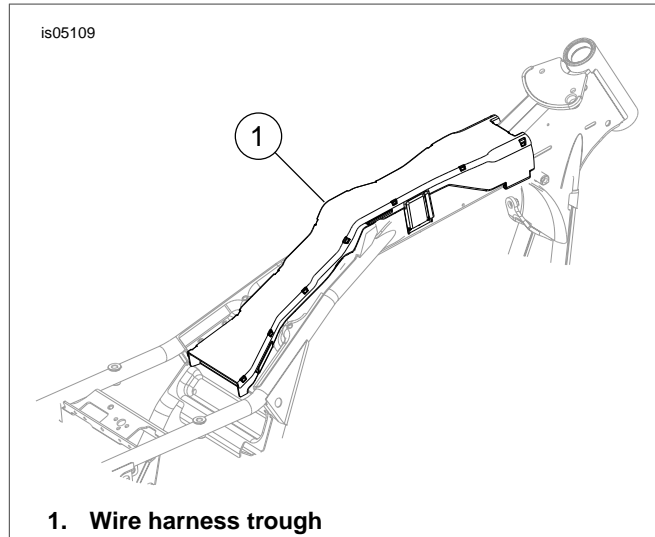

1. Wire harness trough

Figure 3. Wire Harness Trough

Install ACR Overlay Wire Harness

1. Connect ACR overlay harness connectors to ACR leads on cylinder heads.
2. Route overlay harness up and through main harness trough and back to fuse block.
3. See Figure 4. Remove fuel pump fuse (1) from fuse block.
4. **For 2009-Later Models Only:**
 - a. Remove exhaust control fuse from cavities 3A (2) and 3B (3).
 - b. Refer to service manual for instructions to use a terminal pick to remove the R/BK wire terminal from exhaust control cavity 3A. Assemble the R/BK terminated wires into empty cavity 3E.
 - c. Remove the LGN/R wire terminal from cavity 3B. Assemble the LGN/R terminated wires into empty cavity 3F.
 - d. Install exhaust control fuse into cavities 3E (4) and 3F (5).
5. Refer to service manual for instructions to use a terminal pick to remove the Y/GN wire terminal from fuel pump fuse cavity 4A.
6. Assemble Y/GN wire terminal from Step 5 into vacant fuse cavity 3A.
7. Assemble Y/GN terminated wires from ACR overlay harness into original fuel pump cavity 4A and remaining cavity 3B from Step 6.
8. Install fuse block to caddy and replace cable straps in original locations as necessary.
9. See Figure 4. Install original fuel pump fuse and install fuse provided in kit to new circuit in fuse block cavities 3A and 3B.
10. Cut cable strap on ECM connector and remove cap from connector.
11. Remove secondary lock following the procedure in the service manual.

12. Identify cavity 19 and remove plug. Refer to service manual for procedure.

If this is a service replacement of overlay harness, then use Micro Pack 64 Terminal Remover to remove terminal in cavity 19.

13. Install V/GY pin terminal wire from ACR overlay harness into cavity 19 of ECM connector.
14. Install secondary lock following the procedure in the service manual.
15. Install cap to ECM connector and install new cable strap. Reconnect to ECM.
16. Replace cable straps where previously removed and ACR harness as necessary. Allow slack in ACR harness at cylinder heads for relative motion; otherwise cinch up extra lengths and harness as needed to keep from rubbing on gas tank, battery box and frame.
17. Replace cover on main harness wiring trough and replace cable straps previously removed.
18. Install fuse block to caddy. Replace cable straps previously removed.
19. Lift battery box slightly to allow installation of fuse block caddy/battery box interlock.
20. Install battery box front mounting screw.
21. Install fuse block caddy mounting screws.
22. Tighten battery box and fuse block caddy screws to 6-8 ft-lbs (8.1-10.8 Nm).
23. Install ECM caddy and battery to motorcycle frame.

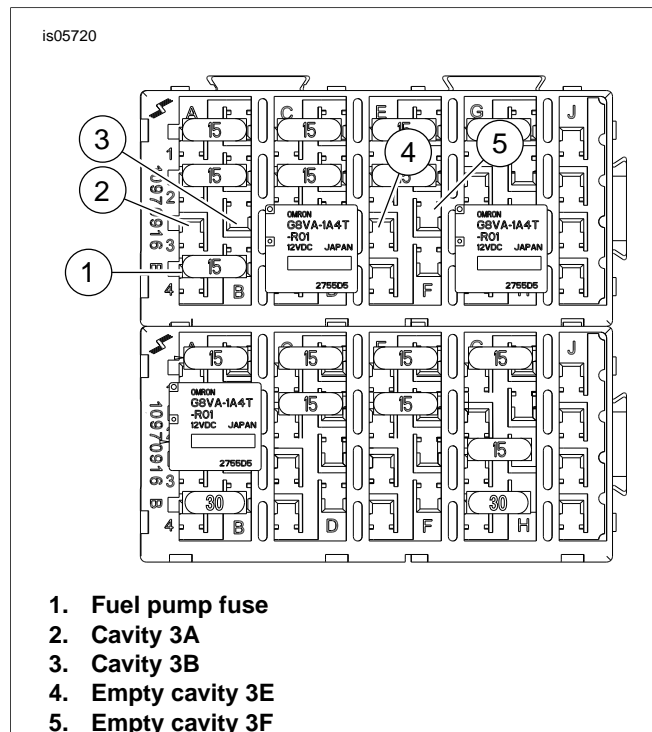

Figure 4. Fuse Block (2008-Earlier Models Shown)

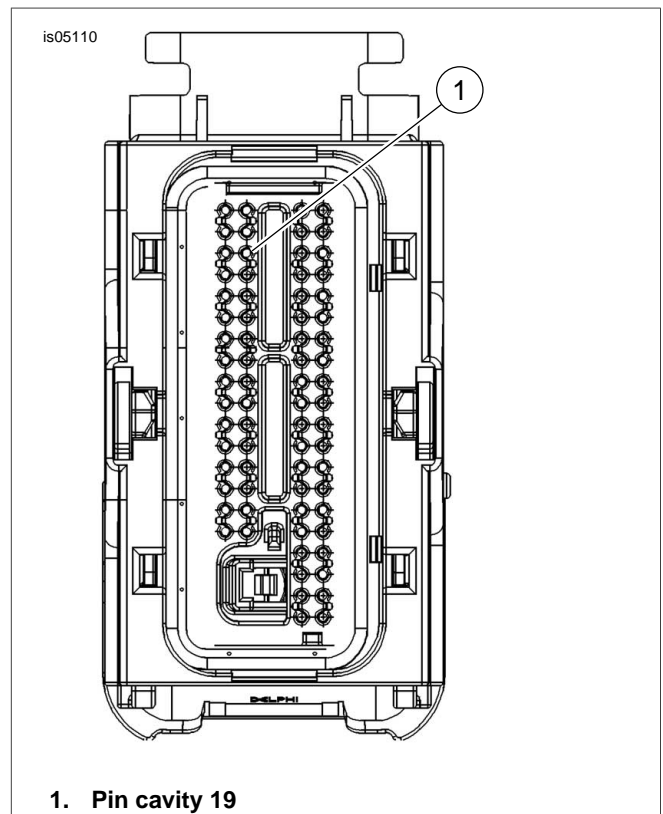

Figure 5. ECM Harness Connector

FINAL ASSEMBLY

WARNING

Connect positive (+) battery cable first. If positive (+) cable should contact ground with negative (-) cable connected, the resulting sparks can cause a battery explosion, which could result in death or serious injury. (00068a)

1. Connect battery cables, positive cable first.

NOTICE

You must recalibrate the ECM when installing this kit. Failure to properly recalibrate the ECM can result in severe engine damage. (00399b)

NOTICE

Installation of this kit requires a calibration update using Digital Technician. Failure to download calibration update before starting motorcycle will result in ACR failure. (00567b)

2. Calibrate the ECM before connecting the ACR overlay harness connectors to the ACR solenoids in the cylinder heads.
3. Install fuel tank according to the instructions in the service manual.
4. Install left side cover and left saddlebag. Refer to service manual.

 **WARNING**

After installing seat, pull upward on seat to be sure it is locked in position. While riding, a loose seat can shift causing loss of control, which could result in death or serious injury. (00070b)

5. Install seat according to the instructions in the service manual.
6. Start and run engine. Repeat several times to check for proper operation.

SERVICE PARTS

is03622

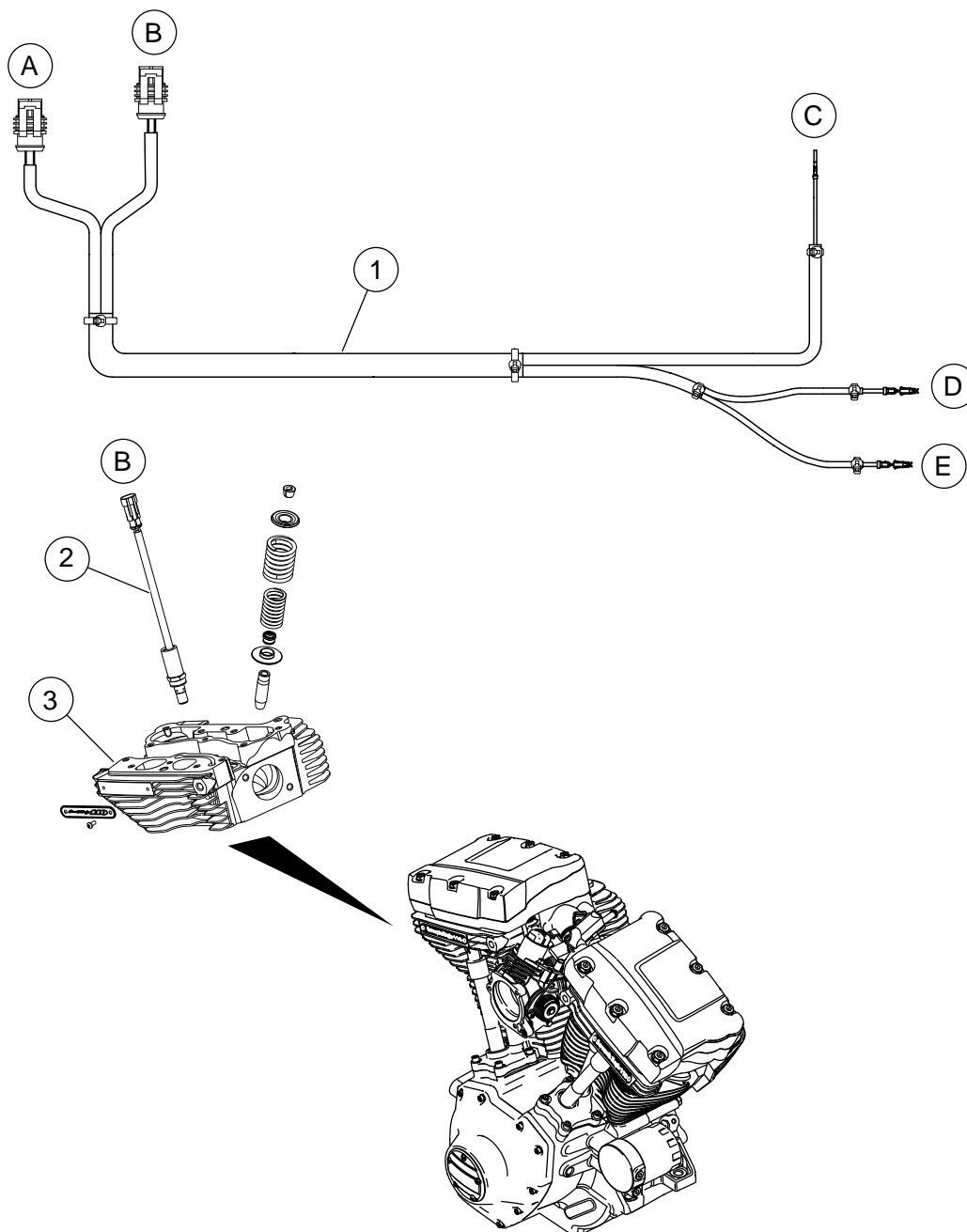

Figure 6. Service Parts: Automatic Compression Release (ACR) Overlay Wire Harness Kit

Table 1. Service Parts: Automatic Compression Release (ACR) Overlay Wire Harness Kit

Item	Description (Quantity)	Part Number	Item	Description (Quantity)	Part Number
1	ACR overlay wire harness	Not Sold Separately	Electrical Connections:		
2	Automatic compression release (ACR)	Reference Only	A	ACR front	
3	Cylinder head	Reference Only	B	ACR rear	
4	Strap, cable (6) (Not Shown)	10006	C	ECM cavity 19	
5	Strap, cable (3) (Not Shown)	10039	D	Fuse block, vacant fuse	
7	Mini-fuse, 15A, not shown	72330-95	E	Fuse block, fuel pump fuse	
6	Strap, cable (6) (Not Shown)	10065			