

SYSTEM DESCRIPTION

Harley-Davidson's Advanced Audio System, developed in partnership with Harman/Kardon, offers improved function and sound quality with an all new integrated design. The base radio features six AM and ten FM radio presets, integrated weather band, and a single disc CD player that is compatible with CD/CDR/CDRW and MP3 format discs. The system also allows for seamless hook up of optional accessories (both current and future) to the base radio display and hand controls.

The Advanced Audio System consists of the following components:

- Radio
- CB module
- Antennas (radio and CB)
- Fairing, rear and sidecar speakers, depending upon model
- Handlebar, rear and sidecar switches, depending upon model
- High Output Amplifier, standard on 2006 sidecar equipped Ultra Classic, CVO Ultra Classic and also as an optional accessory; located under the luggage rack
- Optional accessory Bluetooth Hands Free cell phone interface module and antenna; located inside Tour-Pak
- Optional accessory XM satellite radio module and antenna; located in fairing above radio
- Optional accessory Navigation module and external antenna; module plugs into radio chassis in fairing
- System also designed for the addition of future accessories.

ONBOARD DIAGNOSTICS

General

The system has onboard diagnostics to detect most all fault conditions. Many faults are stored as diagnostic trouble codes (DTCs). While most DTCs can be viewed on the radio diagnostic display, some can only be read using Digital Technician (DTC 1304 thru DTC 1317). Fault conditions that do not generate DTCs, or those for which DTCs cannot be read, can be identified by their symptoms. For troubleshooting and resolving SWITCH INOPERATIVE WITHOUT DTC conditions, as well as other symptoms, see Section 6.5 [ADVANCED AUDIO SYSTEM SYMPTOMS](#).

Radio Diagnostic Display

While depressing and holding any two softkeys (buttons 1-6), turn the ignition switch to ON. Once the H-D logo is displayed, the system automatically performs a complete switch check, scans for current DTCs, and then displays the radio diagnostic display. Release the softkeys only after the radio diagnostic display appears. See A of [Figure 6-1](#).

Press softkey 1, labeled "Run Test," to perform an abbreviated switch test after the initial complete test is performed. To perform the complete test a second time, simply cycle the ignition switch, that is, turn the ignition switch to OFF, and then after a delay of at least ten seconds, turn the switch back to ON while depressing and holding any two softkeys.

If, after the initial diagnostic check, any switches are found to be shorted to B+ or ground, the radio diagnostic display reports the applicable DTC and an abbreviated description. Refer to the appropriate flow chart for resolution of the problem. See B of [Figure 6-1](#).

If no switches are found to be shorted to B+ or ground, the technician may press selected switches to verify functionality. If a switch is functioning properly, the display shows the switch name and the word "OK." If the switch is not working correctly, then the display does not change. All switches, handlebar, passenger, and sidecar, may be tested in this manner. See C of [Figure 6-1](#).

NOTE

If a symptom is present without a DTC, restoring the factory default settings may sometimes resolve the issue. For more information, see Section 6.5 [ADVANCED AUDIO SYSTEM SYMPTOMS, FACTORY DEFAULTS](#).

Pressing softkey 2 displays "Speed Pulses" followed by a speed pulse value. This feature may be employed to quickly verify whether the radio is configured correctly or whether the AVC or J1850 is working properly.

To use this feature, start the motorcycle, access the radio diagnostic display, press softkey 2 to select AVC, and then walk or push the motorcycle while viewing the speed pulse value. If a value other than zero appears, then it is an indication that J1850 and AVC are working properly. If speed pulses are not present, then either the AVC needs to be reconfigured or another problem exists. Refer to DTC U1016 for resolution of the problem if the system is configured correctly. See D of [Figure 6-1](#).

Pressing softkey 3 displays the region and other configuration data, while softkey 4 shows the software version code. See E and F of [Figure 6-1](#).

Softkey 5 is reserved for software upgrades and prompts the technician to install the appropriate CD, while softkey 6 causes the system to exit the radio diagnostic mode and revert to the normal radio display.

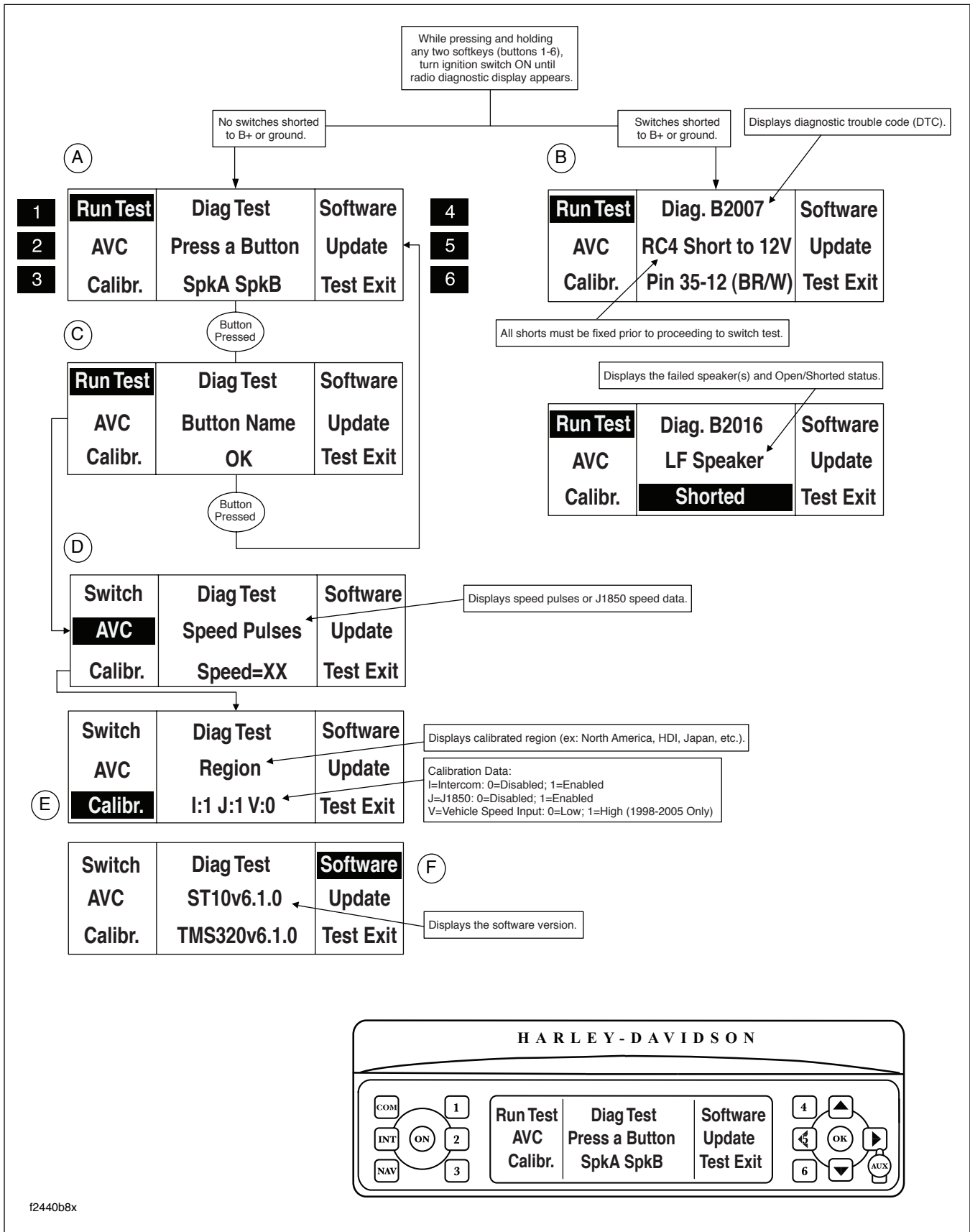

f2440b8x

Figure 6-1. Initial Diagnostics- Radio Diagnostic Display

Table 6-1. Diagnostic Trouble Codes (DTCs) and Symptoms

DTC	DESCRIPTION	FAULT-SET CONDITION	FAULT-CLEAR CONDITION T=TIME R=RESISTANCE
B0563	Battery voltage high	$t \geq 15$ sec. $V \geq 16$ volts	Normal range for $t \geq 15$ seconds
RADIO SWITCH DIAGNOSTICS			
B2006	Radio switch stuck or open	$t \geq 15$ sec.	Normal range for $t \geq 15$ seconds
B2007	Handlebar switch shorted high	Ignition ON after Ignition OFF for at least 10 sec., $t = \text{instantaneous}$	Normal range for $t \geq 15$ seconds
B2008	Handlebar switch shorted low	Ignition ON after Ignition OFF for at least 10 sec., $t = \text{instantaneous}$	Normal range for $t \geq 15$ seconds
B2009	Handlebar switch stuck or open	$t \geq 15$ sec.	Normal range for $t \geq 15$ seconds
B2010	Passenger switch shorted high	Ignition ON after Ignition OFF for at least 10 sec., $t = \text{instantaneous}$	Normal range for $t \geq 15$ seconds
B2011	Passenger switch shorted low	Ignition ON after Ignition OFF for at least 10 sec., $t = \text{instantaneous}$	Normal range for $t \geq 15$ seconds
B2012	Passenger switch stuck or open	$t \geq 15$ sec.	Normal range for $t \geq 15$ seconds
B2013	Sidecar switch shorted high	Ignition ON after Ignition OFF for at least 10 sec., $t = \text{instantaneous}$	Normal range for $t \geq 15$ seconds
B2014	Sidecar switch shorted low	Ignition ON after Ignition OFF for at least 10 sec., $t = \text{instantaneous}$	Normal range for $t \geq 15$ seconds
B2015	Sidecar switch stuck or open	$t \geq 15$ sec.	Normal range for $t \geq 15$ seconds
SPEAKER DIAGNOSTICS			
B2016	Front speakers shorted	$R < 1.5$ ohm tested 1 per ignition cycle $R > \text{TBD}$ when setup as line out ignition ON after Ignition OFF for at least 10 sec., $t = \text{instantaneous}$	$R > 1.5$ ohm tested 1 per ignition cycle
B2017	Front speakers open	$R > 100$ ohm tested 1 per ignition cycle ignition ON after Ignition OFF for at least 10 sec., $t = \text{instantaneous}$	$R < 100$ ohm tested 1 per ignition cycle
B2018	Front speakers shorted to ground	Ignition ON after Ignition OFF for at least 10 sec., $t = \text{instantaneous}$	
B2019	Front speakers shorted to battery	Ignition ON after Ignition OFF for at least 10 sec., $t = \text{instantaneous}$	
B2020	Rear speakers shorted	$R < 1.5$ ohm tested 1 per ignition cycle $R > \text{TBD}$ when setup as line out ignition ON after Ignition OFF for at least 10 sec., $t = \text{instantaneous}$	$R > 1.5$ ohm tested 1 per ignition cycle
B2021	Rear speakers open	$R > 100$ ohm tested 1 per ignition cycle ignition ON after Ignition OFF for at least 10 sec., $t = \text{instantaneous}$	$R < 100$ ohm tested 1 per ignition cycle
B2022	Rear speakers shorted to ground	Ignition ON after Ignition OFF for at least 10 sec., $t = \text{instantaneous}$	
B2023	Rear speakers shorted to battery	Ignition ON after Ignition OFF for at least 10 sec., $t = \text{instantaneous}$	

Table 6-1. Diagnostic Trouble Codes (DTCs) and Symptoms

DTC	DESCRIPTION	FAULT-SET CONDITION	FAULT-CLEAR CONDITION T=TIME R=RESISTANCE
B2024	Sidecar speakers shorted	R<1.5 ohm tested 1 per ignition cycle R>TBD when setup as line out ignition ON or run diagnostics, t=instantaneous	R>1.5 ohm tested 1 per ignition cycle
B2025	Sidecar speakers open	R>100 ohm tested 1 per ignition cycle ignition ON or run diagnostics, t=instantaneous	R<100 ohm tested 1 per ignition cycle
B2026	Sidecar speakers shorted to ground	Ignition ON after Ignition OFF for at least 10 sec., t=instantaneous	
B2027	Sidecar speakers shorted to battery	Ignition ON after Ignition OFF for at least 10 sec., t=instantaneous	
SERIAL DATA BUS DIAGNOSTICS			
U1016	J1850 lost communications with ECM/ICM		
U1300	J1850 bus shorted low		
U1301	J1850 bus shorted high		
U1302	Infotainment bus shorted low/high		
U1304	Infotainment bus lost communications with future		DTC 1304 thru DTC 1317 can only be viewed as historic codes using Digital Technician. The faults are detectable as current codes only if they happen to occur while in the diagnostic mode. To diagnose these conditions without the use of Digital Technician, see Section 6.5 ADVANCED AUDIO SYSTEM SYMPTOMS .
U1305	Infotainment bus lost communications with future		
U1306	Infotainment bus lost communications with hands free phone module		
U1307	Infotainment bus lost communications with CB		
U1308	Infotainment bus lost communications with future		
U1309	Infotainment bus lost communications with future		
U1310	Infotainment bus lost communications with future		
U1311	Infotainment bus lost communications with future		
U1312	Infotainment bus lost communications with future		
U1313	Infotainment bus lost communications with XM		
U1314	Infotainment bus lost communications with navigation		
U1315	Infotainment bus lost communications with future		
U1316	Infotainment bus lost communications with future		
U1317	Infotainment bus lost communications with high output amplifier		

Table 6-1. Diagnostic Trouble Codes (DTCs) and Symptoms

ADVANCED AUDIO SYSTEM SYMPTOMS		GO TO
1	Radio Inoperative	Test 6.5a
2	Poor or No Reception	Test 6.5b
3	Radio Beeps Every 30 Seconds	Test 6.5c
4	CD in Radio Will Not Eject	Test 6.5d
5	Static Present With Engine Running	Test 6.5e
6	Auxiliary Input Audio Distorted	Test 6.5f
7	CB Transmitter Inoperative and SWR Adjustment	Test 6.5g (Part 1 of 4)
8	CB Receiver Inoperative	Test 6.5h (Part 1 of 3)
9	Intercom Inoperative	Test 6.5i
10	Handheld Microphone/PTT Inoperative	Test 6.5j (Part 1 of 2)
11	Speaker Switch Malfunction	Test 6.5k
12	Headset Speakers Inoperative	Test 6.5l (Part 1 of 5)
13	No or Low Audio From Microphones	Test 6.5m (Part 1 of 4)
14	No or Low Audio With High Output Amplifier	Test 6.5n (Part 1 of 2)
15	No or Low Audio From XM or XM Inoperative	Test 6.5o (Part 1 of 2)
16	XM - No or Intermittent Reception	Test 6.5p
17	Navigation Inoperative	Test 6.5q (Part 1 of 2)
18	AVC Inoperative	Test 6.5r
19	Handlebar, Passenger or Sidecar Switches Inoperative	Test 6.5s (Part 1 of 4)
20	CD Skipping	Test 6.5t
21	Hands Free Phone Module Inoperative No or Low Audio <u>To</u> Hands Free Phone Module No or Low Audio <u>From</u> Hands Free Phone Module Hands Free Phone Module - Phone Not Pairing	Test 6.5u (Part 1 of 5)

GENERAL

The sound system is designed to capture faults for each of the radio switch inputs. When a fault is detected, a DTC is generated. The DTC and related data appears on the radio display when the system is in the diagnostic mode.

Table 6-2. Code Description

DTC	DESCRIPTION
B2006	Radio Switch Stuck or Open
B2007	Handlebar Switch Shorted High
B2008	Handlebar Switch Shorted Low
B2009	Handlebar Switch Stuck or Open
B2010	Passenger Switch Shorted High
B2011	Passenger Switch Shorted Low
B2012	Passenger Switch Stuck or Open
B2013	Sidecar Switch Shorted High
B2014	Sidecar Switch Shorted Low
B2015	Sidecar Switch Stuck or Open

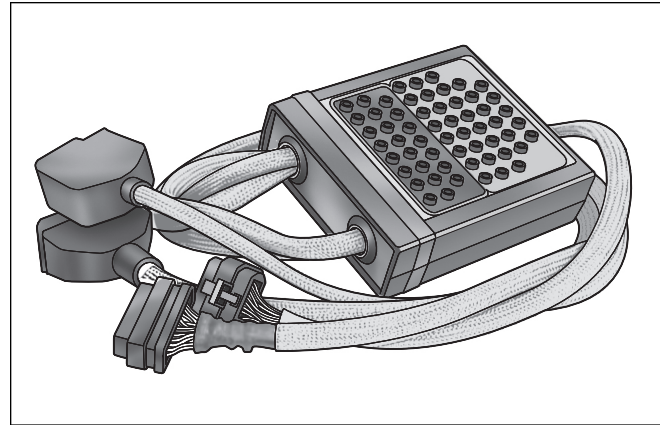

Figure 6-2. Radio Breakout Box (Part No. HD-47918)

DIAGNOSTICS

Diagnostic Notes

The reference numbers below correlate with the circled numbers on the [Test 6.2a](#) thru [Test 6.2j](#) flow charts.

1. Install RADIO BREAKOUT BOX (Part No. HD-47918).
2. Install BREAKOUT BOX (Part No. HD-42682) between handlebar switch and interconnect harness.
3. Use HARNESS CONNECTOR TEST KIT (Part No. HD-41404A), brown socket probes and patch cord.
4. Use HARNESS CONNECTOR TEST KIT (Part No. HD-41404A), brown pin probe and patch cord.

Test 6.2a

DTC B2006 THRU B2015

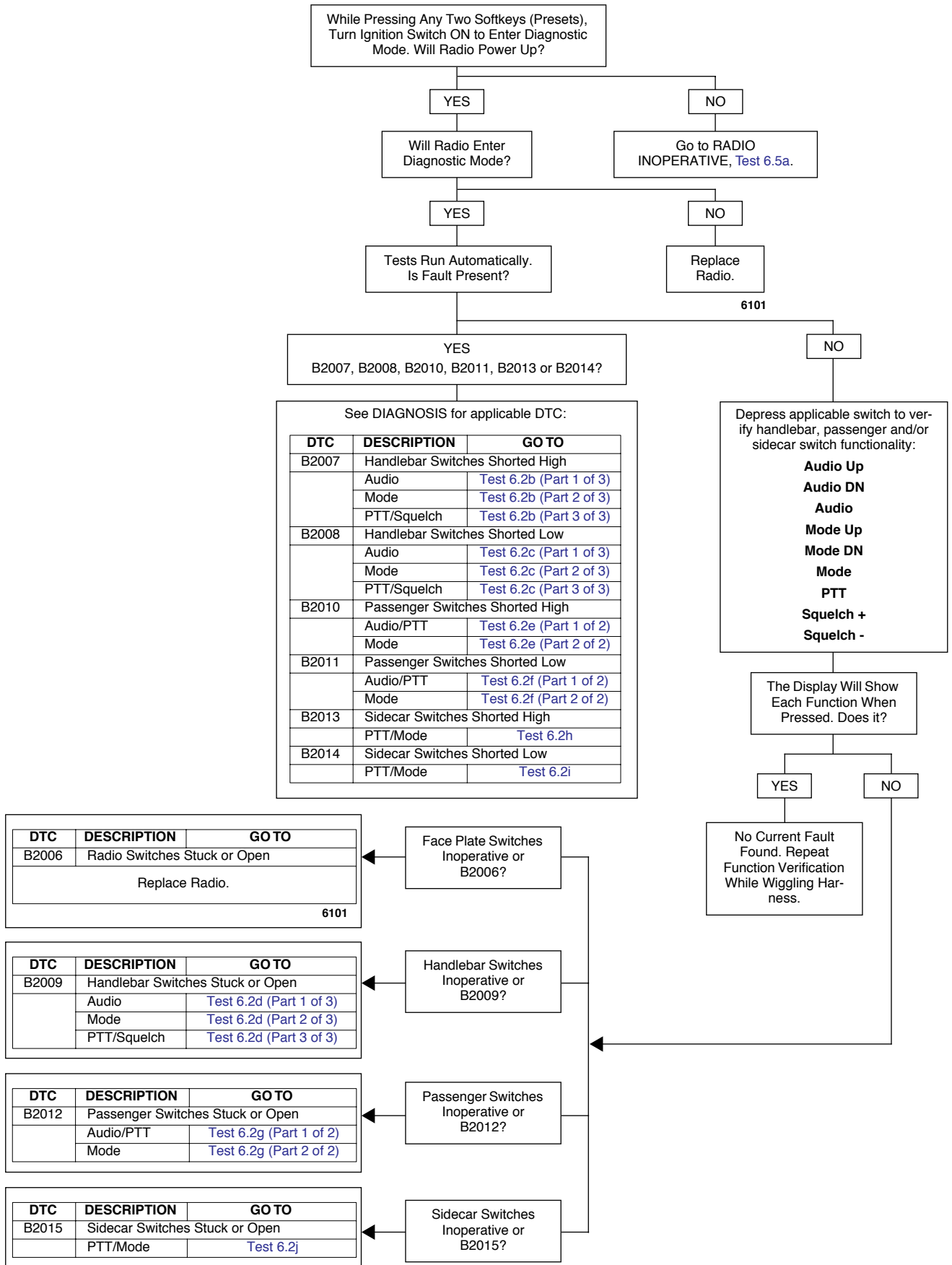

Test 6.2b (Part 1 of 3)

HANDLEBAR AUDIO SWITCH SHORTED HIGH: DTC B2007

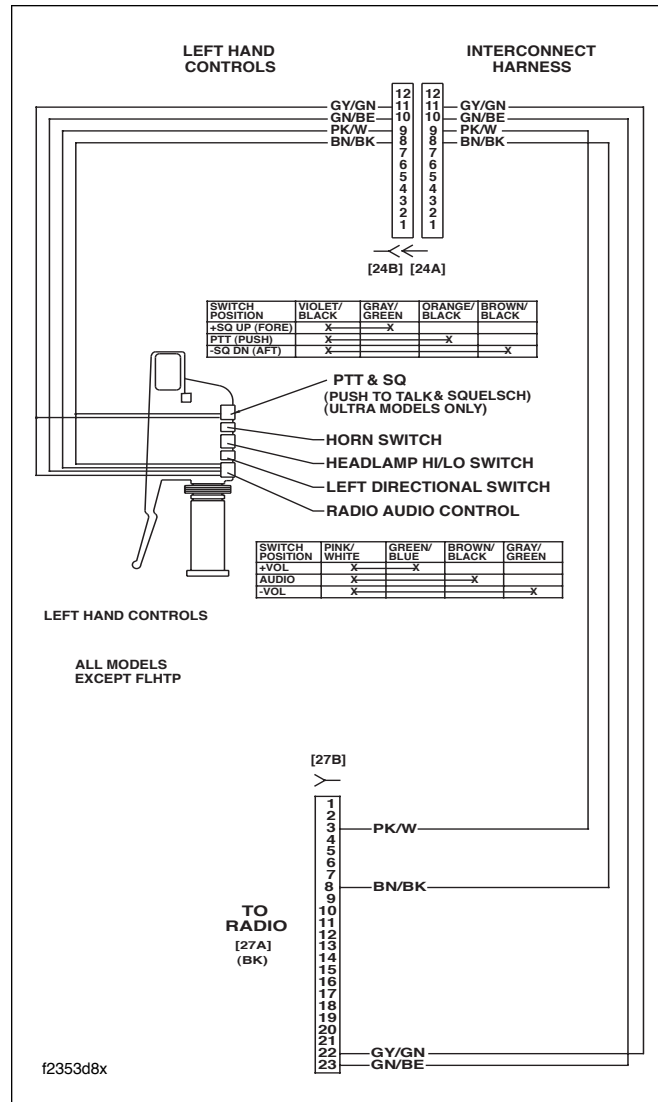
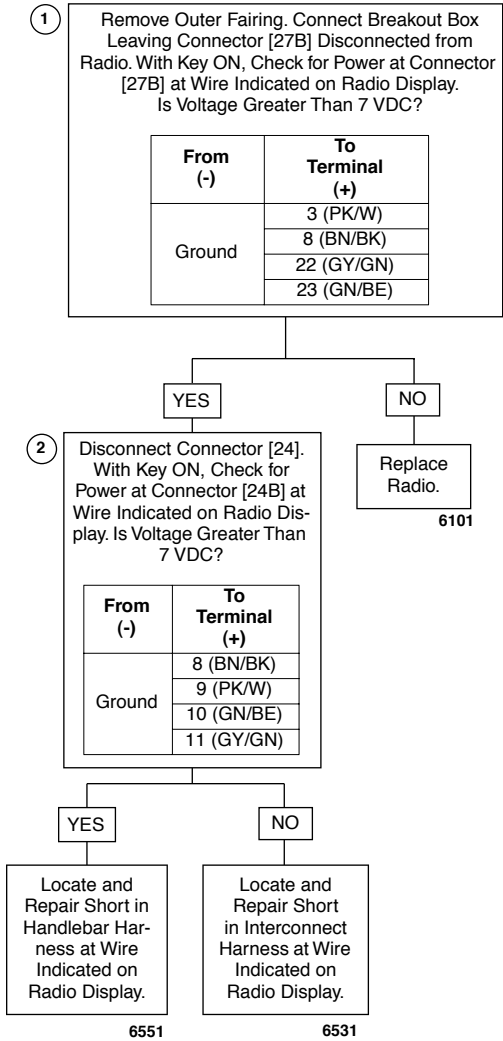

Figure 6-3. Handlebar Audio Switch Circuit



Verify DTC is no longer present using radio diagnostics. See Section 6.1 RADIO DIAGNOSTICS. Confirm proper operation with no DTCs.

Table 6-3. Wire Harness Connectors

NO.	DESCRIPTION	MODEL	TYPE	LOCATION
[24]	Interconnect Harness to Left Handlebar Switches	FLHX, FLHTC/U	12-Place Deutsch (Gray)	Inner Fairing- Left Fairing Support Brace
		FLTR	12-Place Deutsch (Gray)	Inner Fairing- Left Side of Radio Bracket
[27]	Radio	All	23-Place Amp	Inner Fairing- Back of Radio (Right Side)

Test 6.2b (Part 2 of 3)

HANDLEBAR MODE SWITCH SHORTED HIGH: DTC B2007

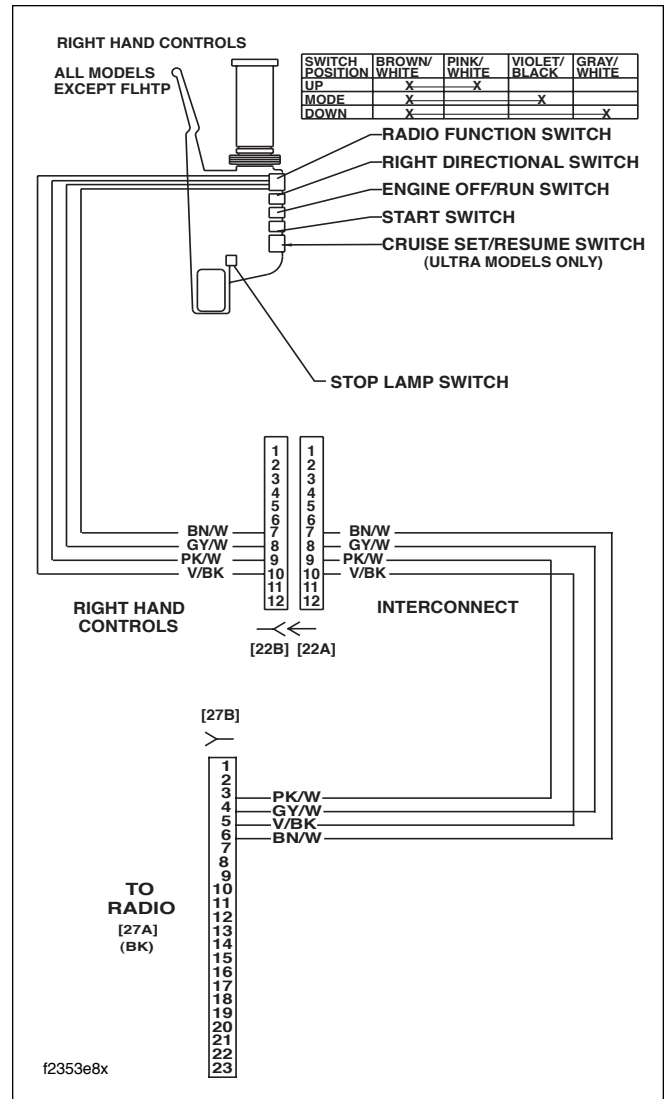
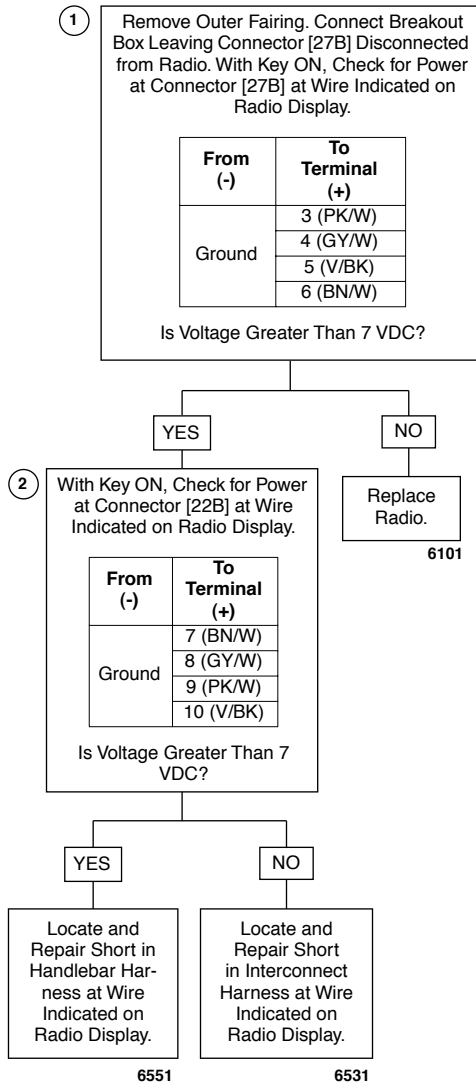

Figure 6-4. Handlebar Mode Switch Circuit



Verify DTC is no longer present using radio diagnostics. See Section 6.1 RADIO DIAGNOSTICS. Confirm proper operation with no DTCs.

Table 6-4. Wire Harness Connectors

NO.	DESCRIPTION	MODEL	TYPE	LOCATION
[22]	Interconnect Harness to Right Handlebar Switches	FLHX, FLHTC/U	12-Place Deutsch (Black)	Inner Fairing - Fork Stem Nut Lock Plate (Left Side)
		FLTR	12-Place Deutsch (Black)	Inner Fairing- Left Side of Radio Bracket
[27]	Radio	All	23-Place Amp	Inner Fairing- Back of Radio (Right Side)

Test 6.2b (Part 3 of 3)

HANDLEBAR PTT/SQUELCH SWITCH SHORTED HIGH: DTC B2007

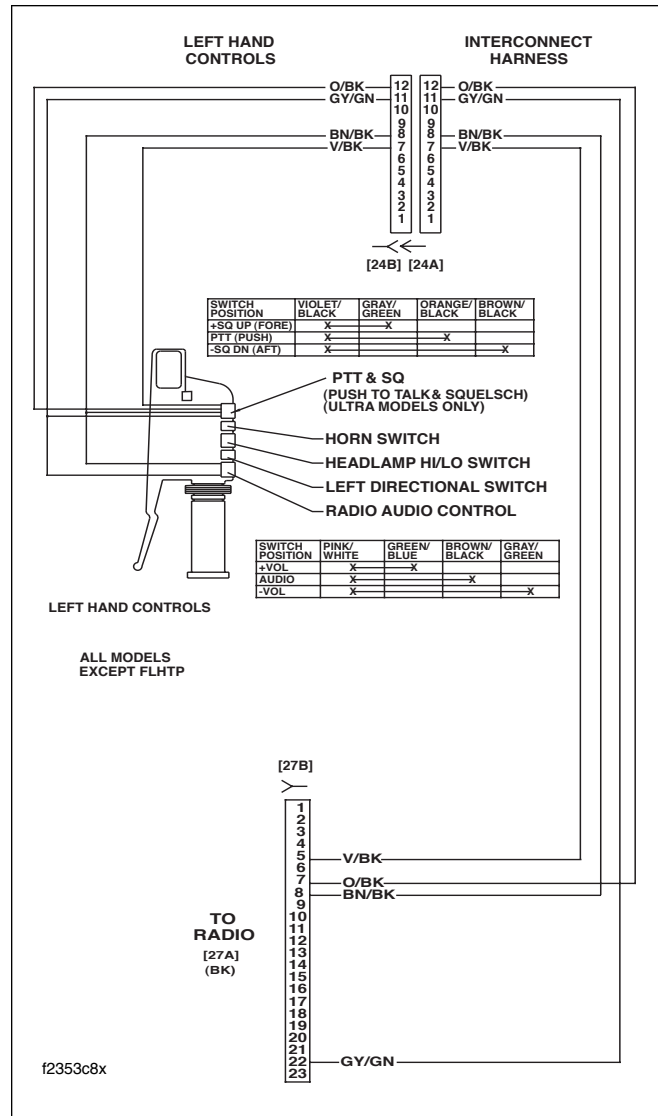
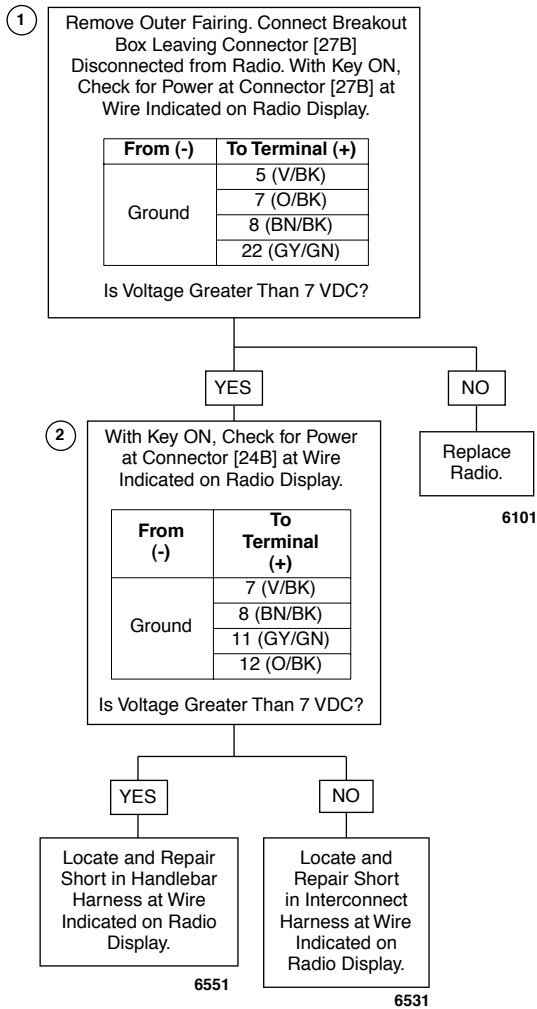

Figure 6-5. Handlebar PTT/Squelch Switch Circuit



Verify DTC is no longer present using radio diagnostics. See Section 6.1 RADIO DIAGNOSTICS. Confirm proper operation with no DTCs.

Table 6-5. Wire Harness Connectors

NO.	DESCRIPTION	MODEL	TYPE	LOCATION
[24]	Interconnect Harness to Left Handlebar Switches	FLHX, FLHTC/U	12-Place Deutsch (Gray)	Inner Fairing- Left Fairing Support Brace
		FLTR	12-Place Deutsch (Gray)	Inner Fairing- Left Side of Radio Bracket
[27]	Radio	All	23-Place Amp	Inner Fairing- Back of Radio (Right Side)

Test 6.2c (Part 1 of 3)

HANDLEBAR AUDIO SWITCH SHORTED LOW: DTC B2008

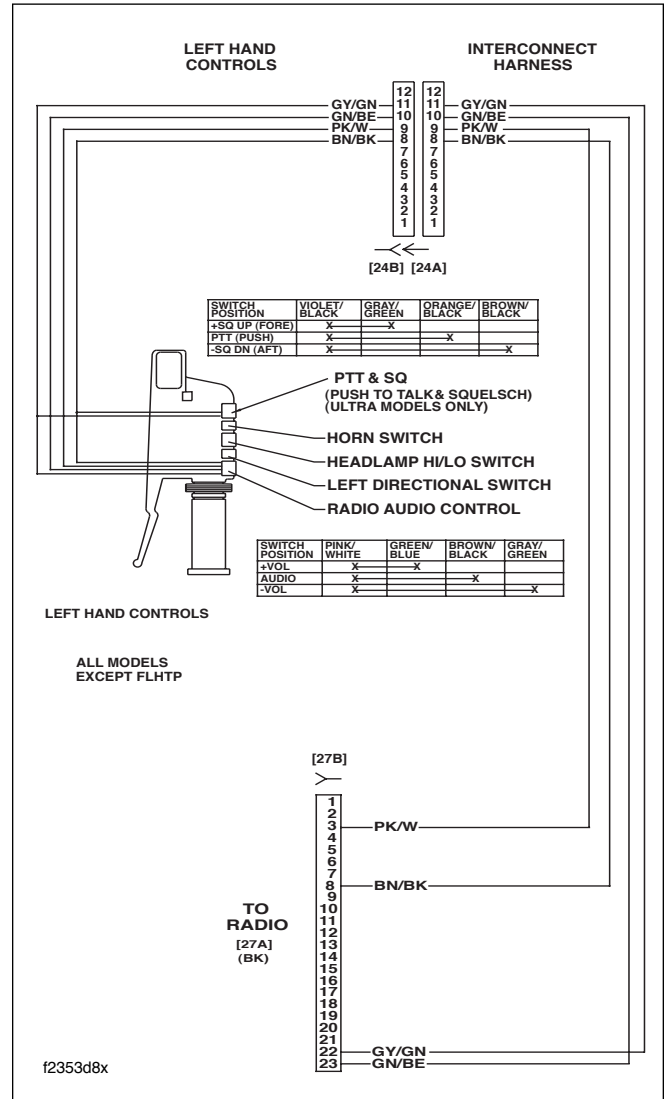
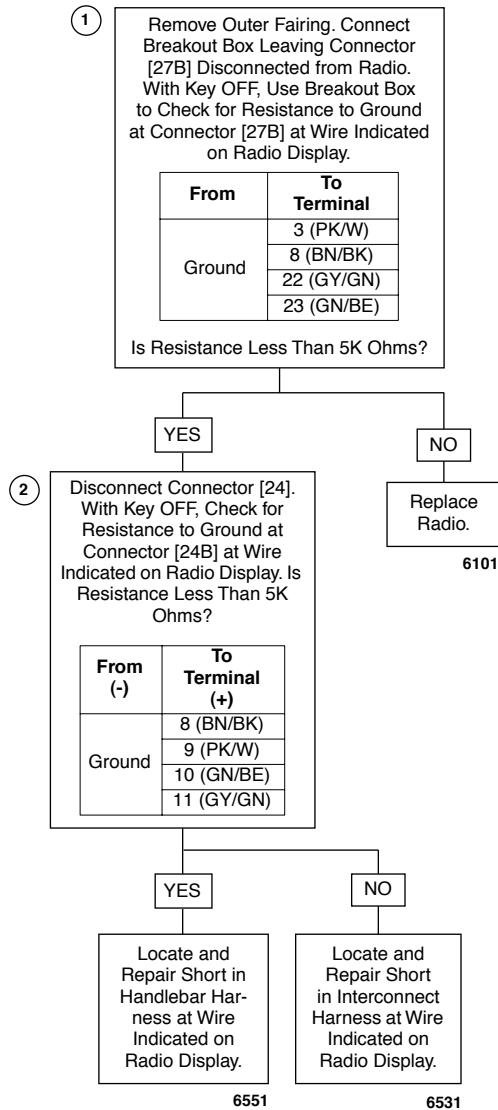

Figure 6-6. Handlebar Audio Switch Circuit



Verify DTC is no longer present using radio diagnostics. See Section 6.1 RADIO DIAGNOSTICS. Confirm proper operation with no DTCs.

Table 6-6. Wire Harness Connectors

NO.	DESCRIPTION	MODEL	TYPE	LOCATION
[24]	Interconnect Harness to Left Handlebar Switches	FLHX, FLHTC/U	12-Place Deutsch (Gray)	Inner Fairing- Left Fairing Support Brace
		FLTR	12-Place Deutsch (Gray)	Inner Fairing- Left Side of Radio Bracket
[27]	Radio	All	23-Place Amp	Inner Fairing- Back of Radio (Right Side)

Test 6.2c (Part 2 of 3)

HANDLEBAR MODE SWITCH SHORTED LOW: DTC B2008

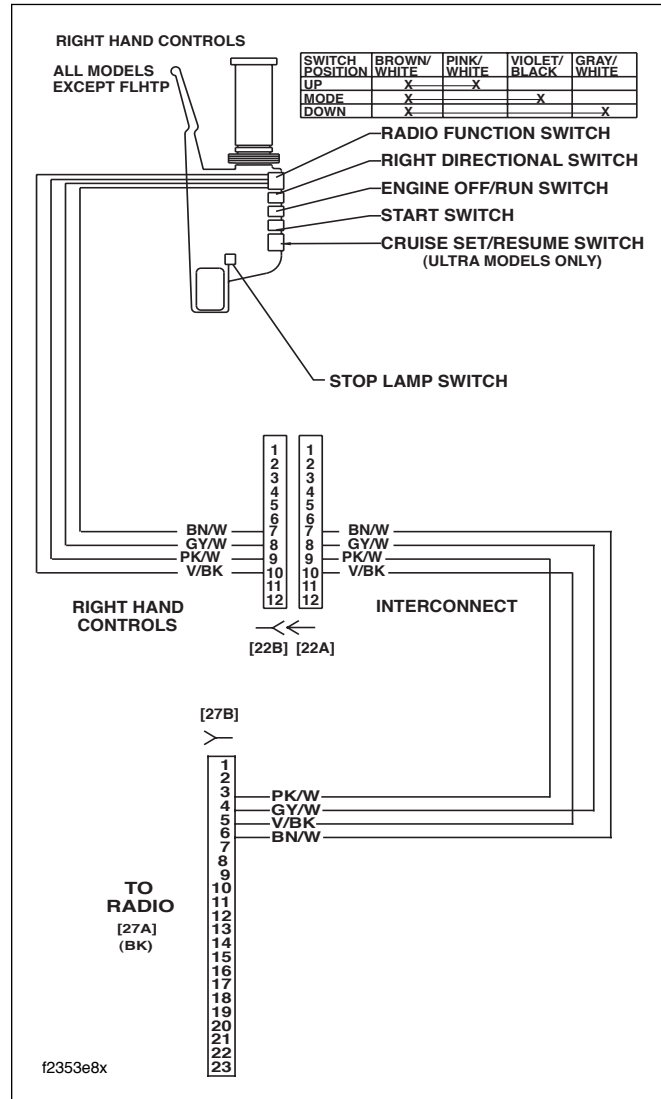
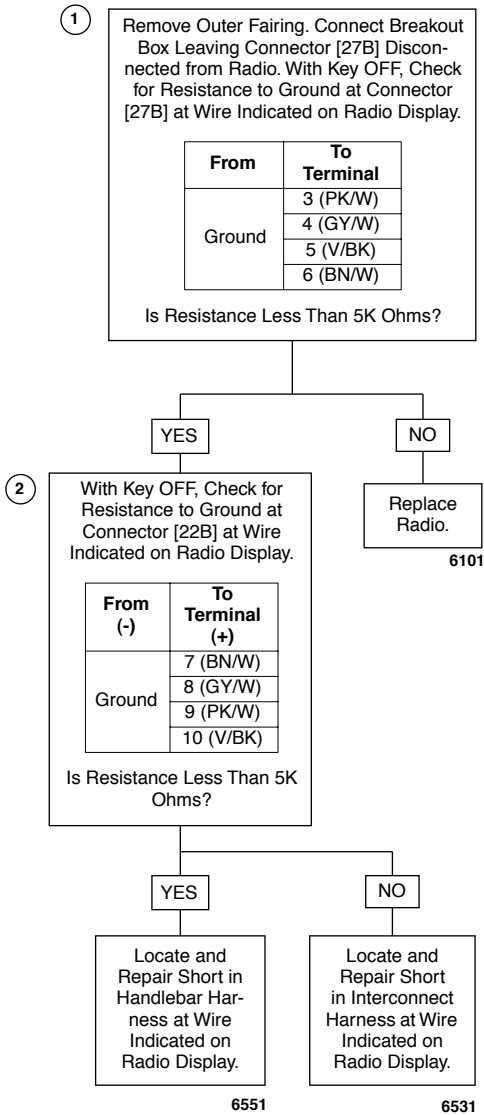

Figure 6-7. Handlebar Mode Switch Circuit



Verify DTC is no longer present using radio diagnostics. See Section 6.1 RADIO DIAGNOSTICS. Confirm proper operation with no DTCs.

Table 6-7. Wire Harness Connectors

NO.	DESCRIPTION	MODEL	TYPE	LOCATION
[22]	Interconnect Harness to Right Handlebar Switches	FLHX, FLHTC/U	12-Place Deutsch (Black)	Inner Fairing - Fork Stem Nut Lock Plate (Left Side)
		FLTR	12-Place Deutsch (Black)	Inner Fairing- Left Side of Radio Bracket
[27]	Radio	All	23-Place Amp	Inner Fairing- Back of Radio (Right Side)

Test 6.2c (Part 3 of 3)

HANDLEBAR PTT/SQUELCH SWITCH SHORTED LOW: DTC B2008

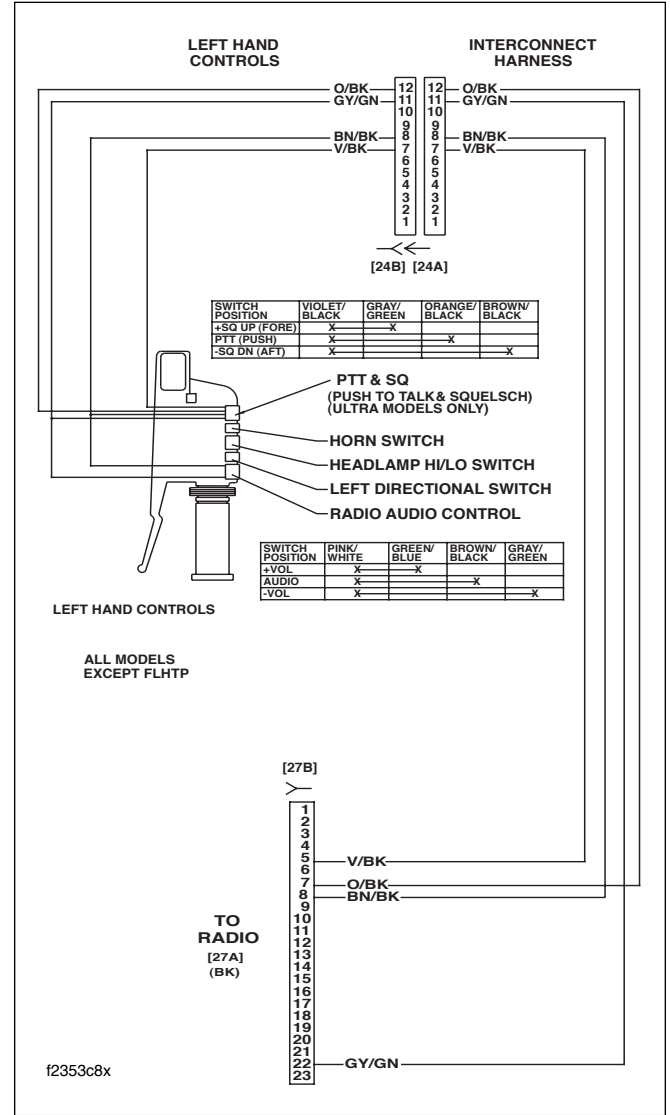
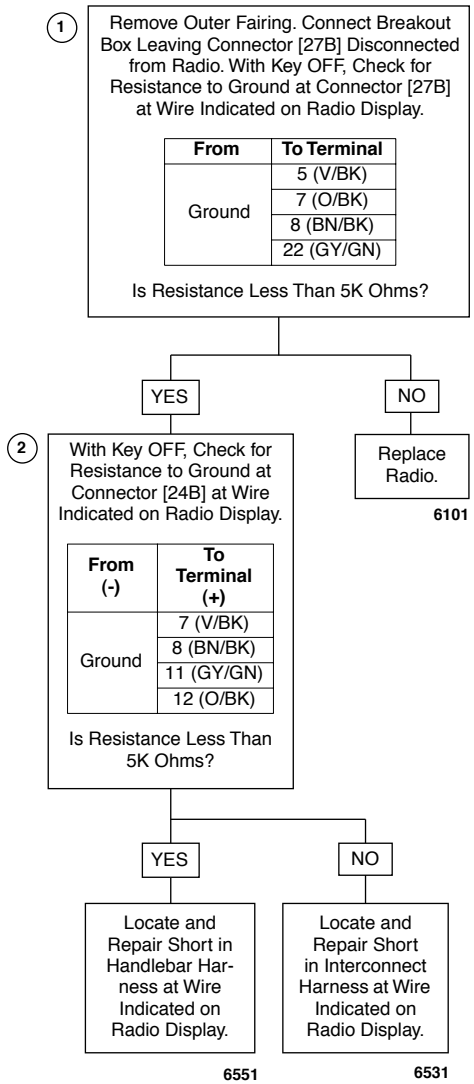

Figure 6-8. Handlebar PTT/Squelch Switch Circuit



Verify DTC is no longer present using radio diagnostics. See Section 6.1 RADIO DIAGNOSTICS. Confirm proper operation with no DTCs.

Table 6-8. Wire Harness Connectors

NO.	DESCRIPTION	MODEL	TYPE	LOCATION
[24]	Interconnect Harness to Left Handlebar Switches	FLHX, FLHTC/U	12-Place Deutsch (Gray)	Inner Fairing- Left Fairing Support Brace
		FLTR	12-Place Deutsch (Gray)	Inner Fairing- Left Side of Radio Bracket
[27]	Radio	All	23-Place Amp	Inner Fairing- Back of Radio (Right Side)

Test 6.2d (Part 1 of 3)

HANDLEBAR AUDIO SWITCH STUCK OR OPEN: DTC B2009

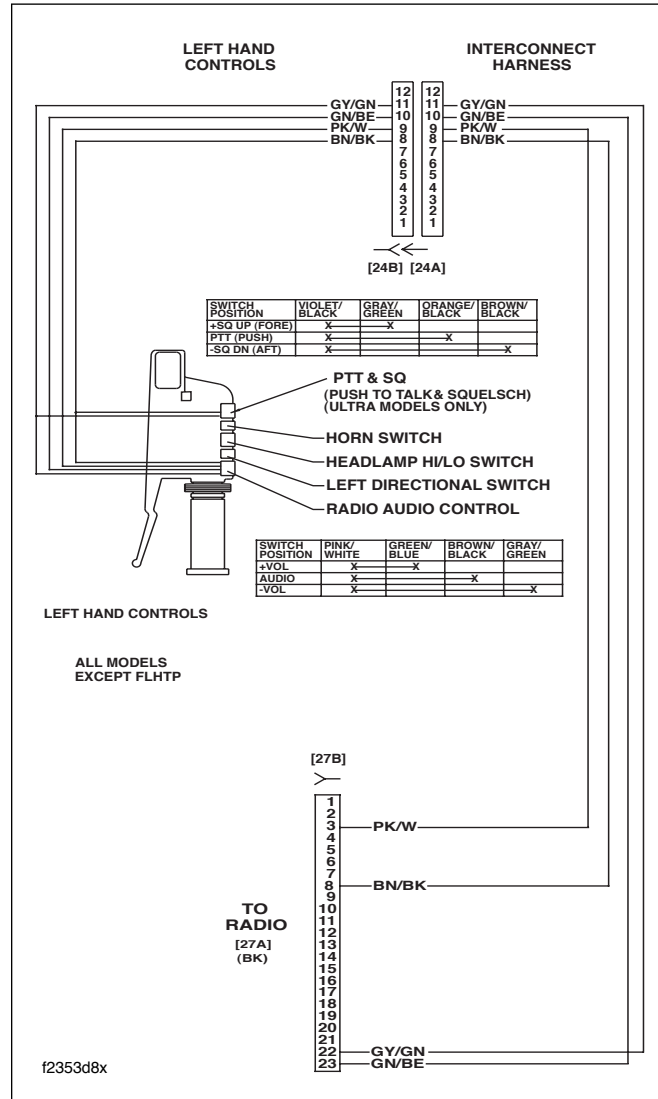
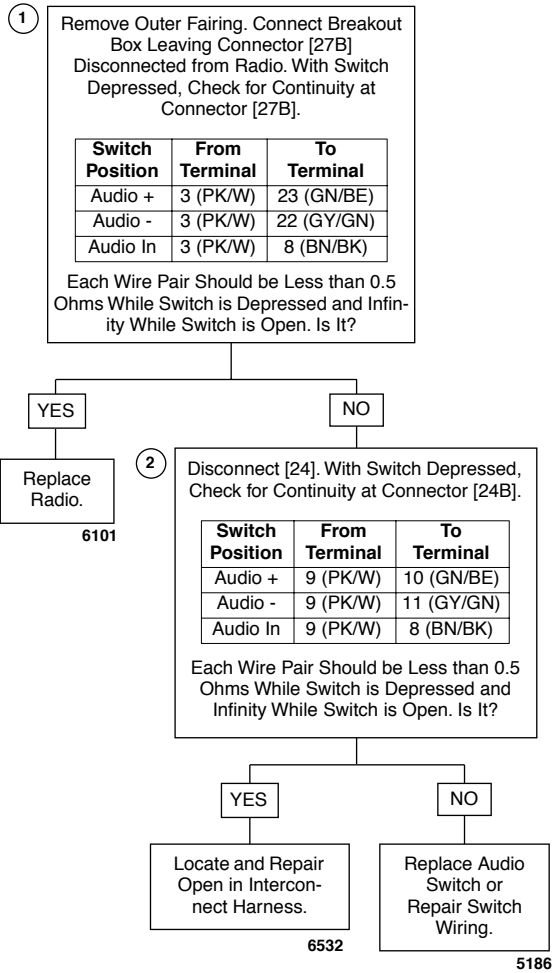

Figure 6-9. Handlebar Audio Switch Circuit



Verify DTC is no longer present using radio diagnostics. See Section 6.1 RADIO DIAGNOSTICS. Confirm proper operation with no DTCs.

Table 6-9. Wire Harness Connectors

NO.	DESCRIPTION	MODEL	TYPE	LOCATION
[24]	Interconnect Harness to Left Handlebar Switches	FLHX, FLHTC/U	12-Place Deutsch (Gray)	Inner Fairing- Left Fairing Support Brace
		FLTR	12-Place Deutsch (Gray)	Inner Fairing- Left Side of Radio Bracket
[27]	Radio	All	23-Place Amp	Inner Fairing- Back of Radio (Right Side)

Test 6.2d (Part 2 of 3)

HANDLEBAR MODE SWITCH STUCK OR OPEN: DTC B2009

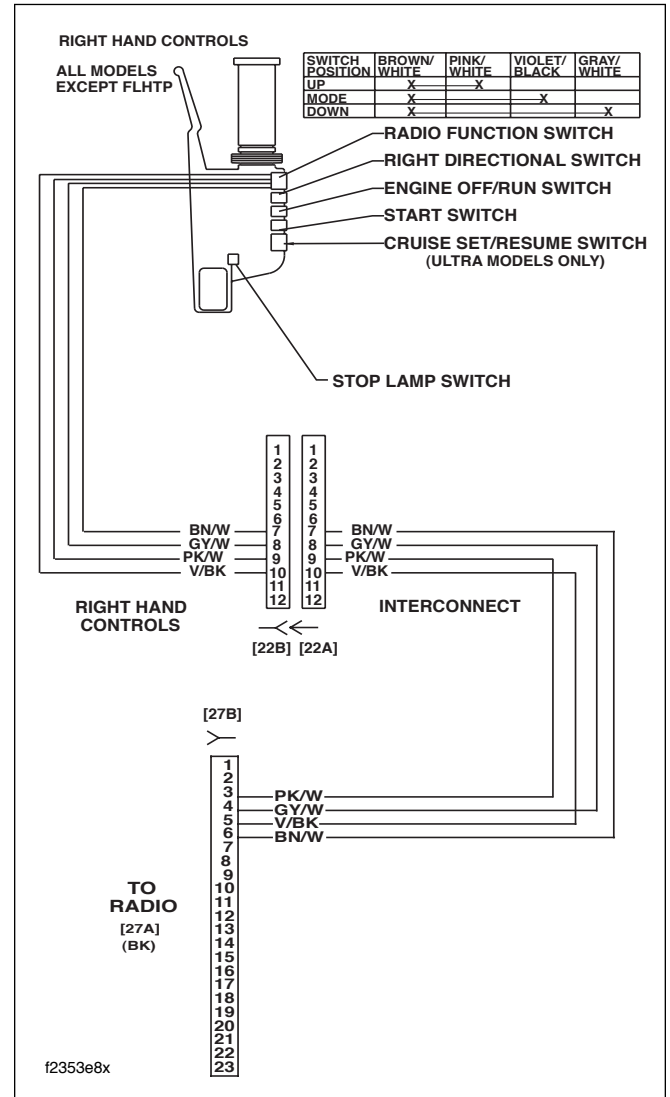
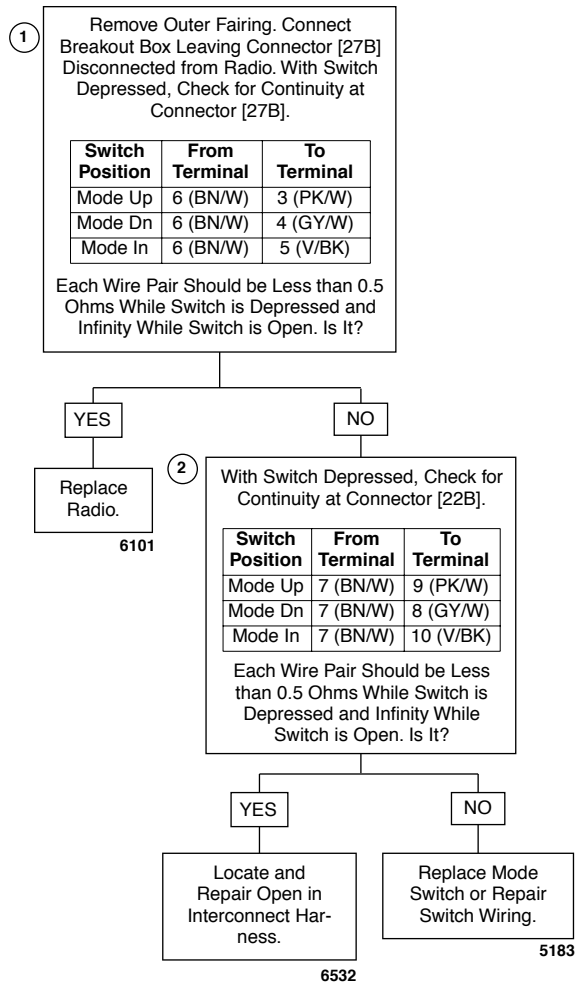

Figure 6-10. Handlebar Mode Switch Circuit



Verify DTC is no longer present using radio diagnostics. See Section 6.1 RADIO DIAGNOSTICS. Confirm proper operation with no DTCs.

Table 6-10. Wire Harness Connectors

NO.	DESCRIPTION	MODEL	TYPE	LOCATION
[22]	Interconnect Harness to Right Handlebar Switches	FLHX, FLHTC/U	12-Place Deutsch (Black)	Inner Fairing - Fork Stem Nut Lock Plate (Left Side)
		FLTR	12-Place Deutsch (Black)	Inner Fairing- Left Side of Radio Bracket
[27]	Radio	All	23-Place Amp	Inner Fairing- Back of Radio (Right Side)

Test 6.2d (Part 3 of 3)

HANDLEBAR PTT/SQUELCH SWITCH STUCK OR OPEN: DTC B2009

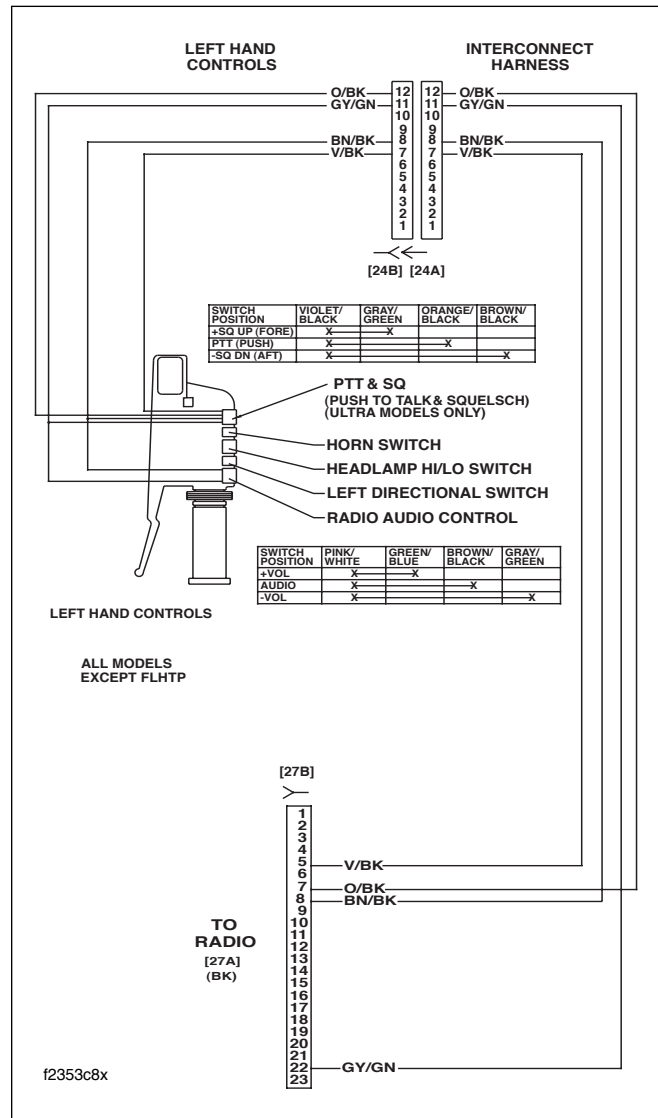
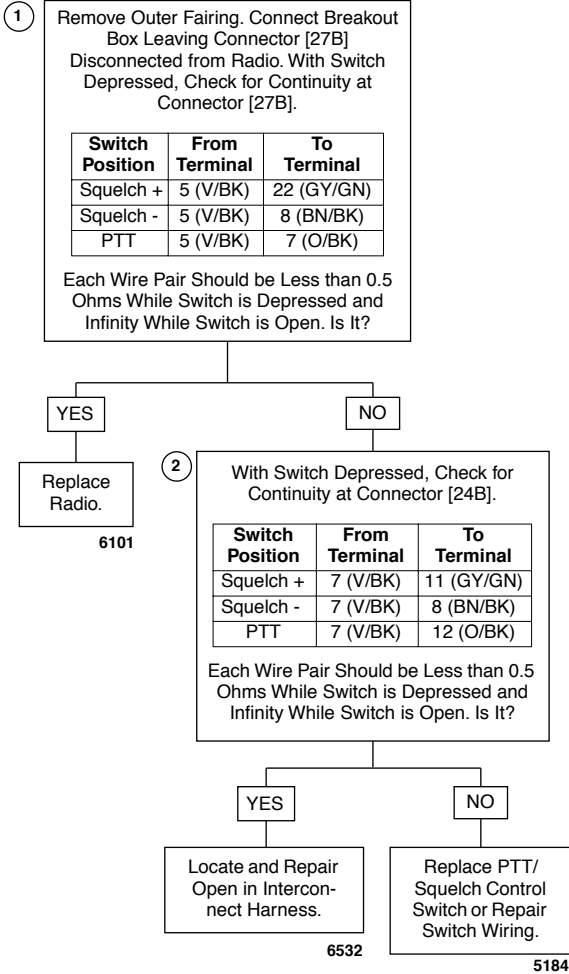

Figure 6-11. Handlebar PTT/Squelch Switch Circuit



Verify DTC is no longer present using radio diagnostics. See Section 6.1 RADIO DIAGNOSTICS. Confirm proper operation with no DTCs.

Table 6-11. Wire Harness Connectors

NO.	DESCRIPTION	MODEL	TYPE	LOCATION
[24]	Interconnect Harness to Left Handlebar Switches	FLHX, FLHTC/U	12-Place Deutsch (Gray)	Inner Fairing- Left Fairing Support Brace
		FLTR	12-Place Deutsch (Gray)	Inner Fairing- Left Side of Radio Bracket
[27]	Radio	All	23-Place Amp	Inner Fairing- Back of Radio (Right Side)

Test 6.2e (Part 1 of 2)

PASSENGER AUDIO/PTT SWITCH SHORTED HIGH: DTC B2010

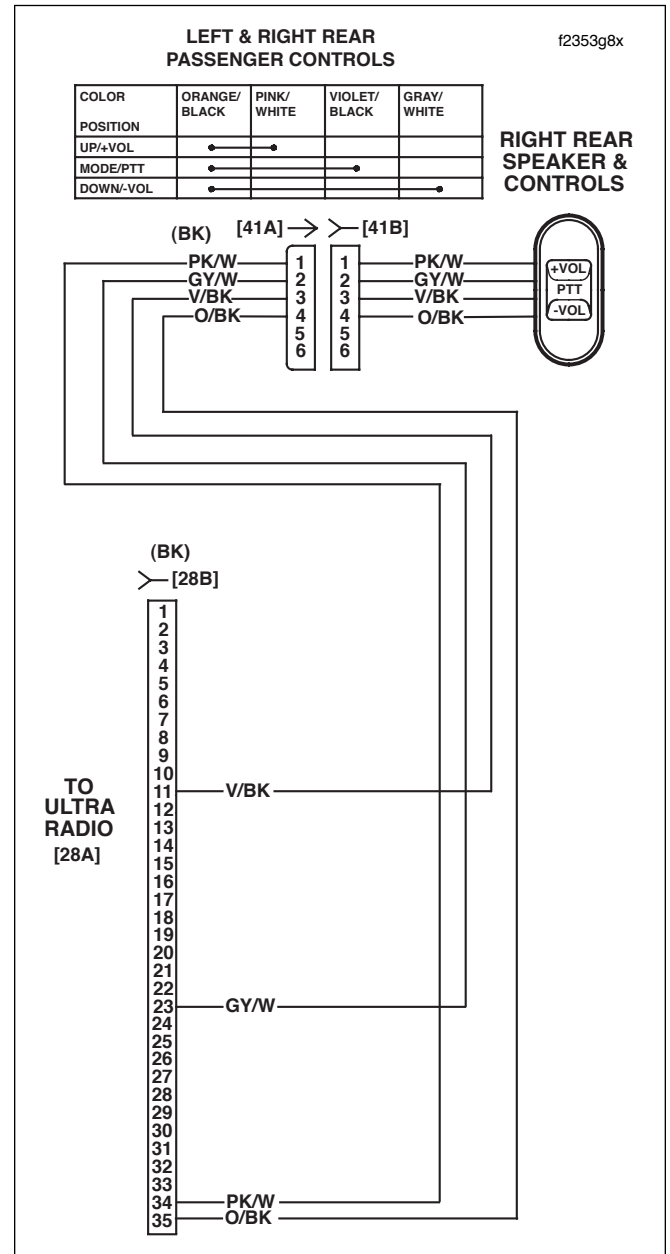
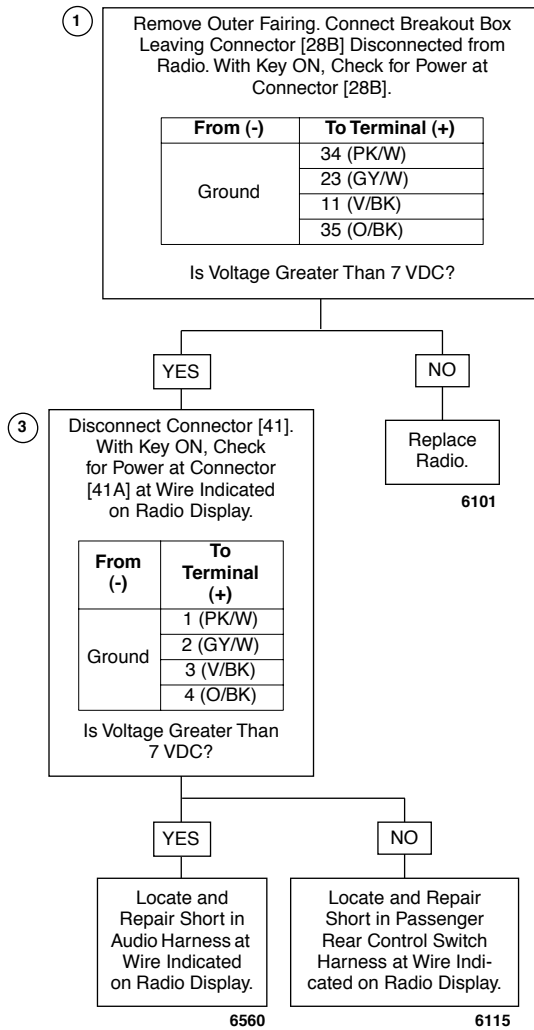

Figure 6-12. Passenger Audio/PTT Switch Circuit



Verify DTC is no longer present using radio diagnostics. See Section 6.1 RADIO DIAGNOSTICS. Confirm proper operation with no DTCs.

Table 6-12. Wire Harness Connectors

NO.	DESCRIPTION	TYPE	LOCATION
[28]	Radio	35-Place Amp	Inner Fairing- Back of Radio (Left Side)
[41]	Rear Right Speaker/Passenger Controls	6-Place Mini-Deutsch	Inside Rear Right Speaker Box

Test 6.2e (Part 2 of 2)

PASSENGER MODE SWITCH SHORTED HIGH: DTC B2010

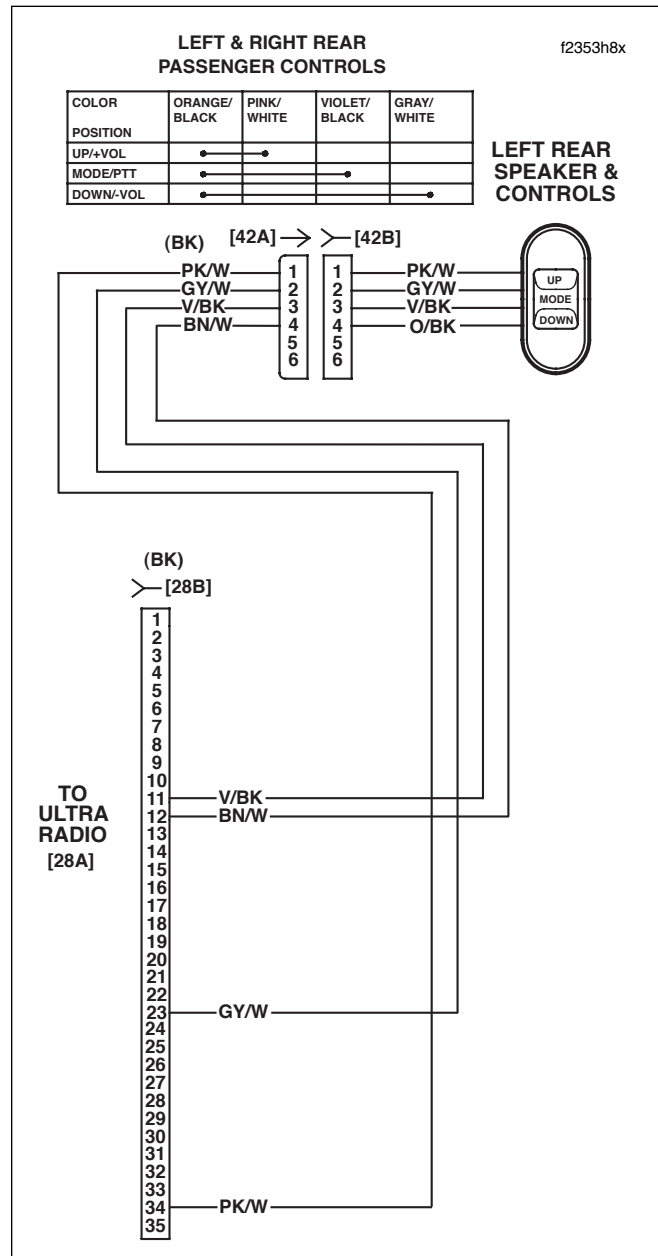
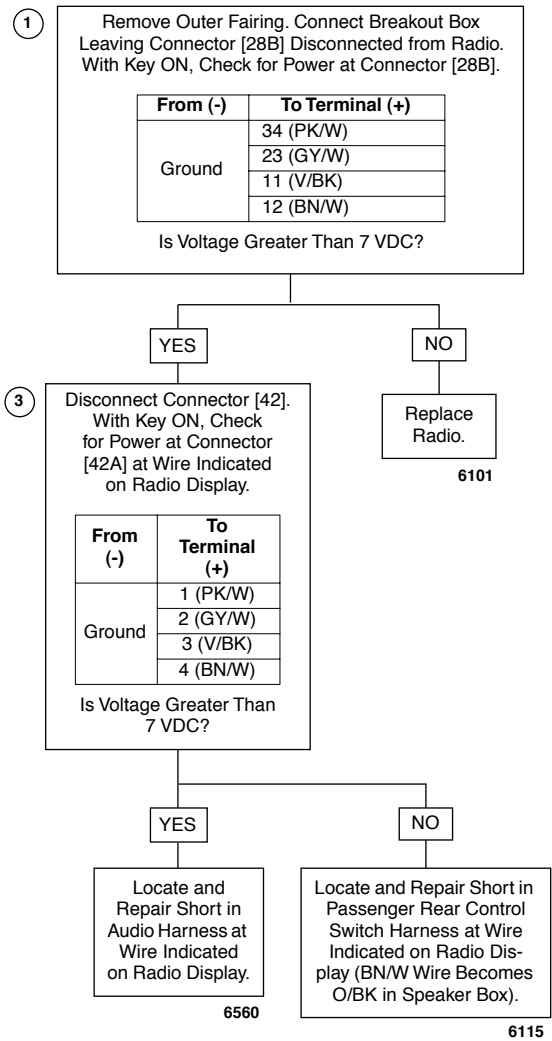

Figure 6-13. Passenger Mode Switch Circuit



Verify DTC is no longer present using radio diagnostics. See Section 6.1 RADIO DIAGNOSTICS. Confirm proper operation with no DTCs.

Table 6-13. Wire Harness Connectors

NO.	DESCRIPTION	TYPE	LOCATION
[28]	Radio	35-Place Amp	Inner Fairing- Back of Radio (Left Side)
[42]	Rear Left Speaker/Passenger Controls	6-Place Mini-Deutsch	Inside Rear Left Speaker Box

Test 6.2f (Part 1 of 2)

PASSENGER AUDIO/PTT SWITCH SHORTED LOW: DTC B2011

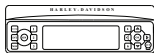
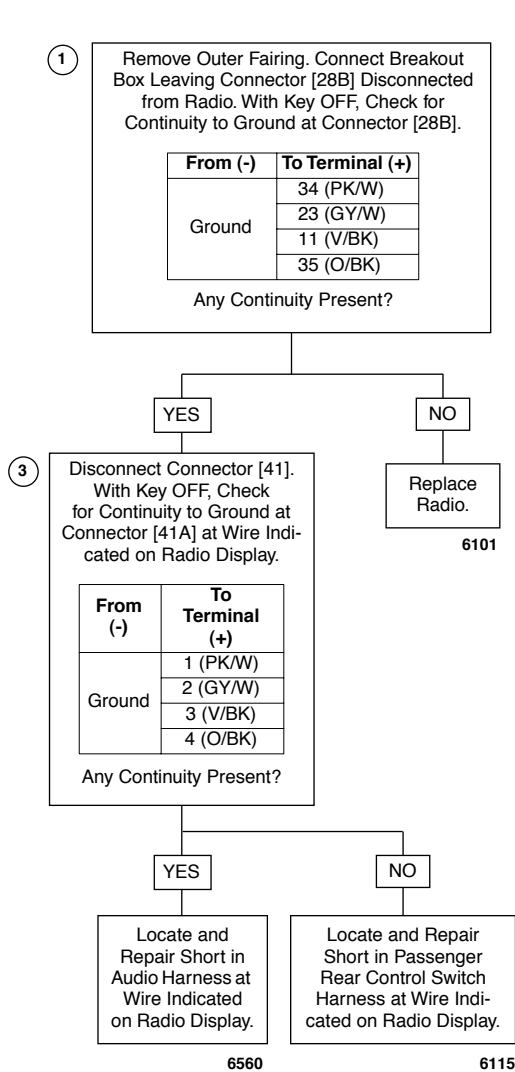

Verify DTC is no longer present using radio diagnostics. See Section 6.1 RADIO DIAGNOSTICS. Confirm proper operation with no DTCs.

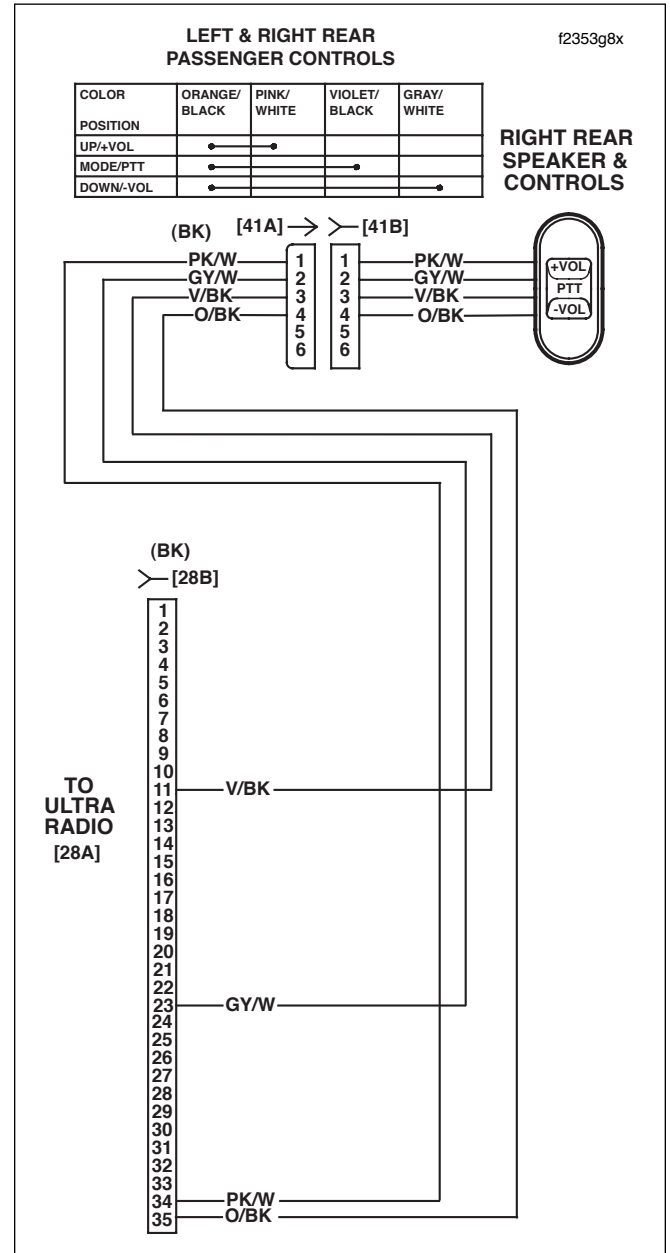

Figure 6-14. Passenger Audio/PTT Switch Circuit

Table 6-14. Wire Harness Connectors

NO.	DESCRIPTION	TYPE	LOCATION
[28]	Radio	35-Place Amp	Inner Fairing- Back of Radio (Left Side)
[41]	Rear Right Speaker/Passenger Controls	6-Place Mini-Deutsch	Inside Rear Right Speaker Box

Test 6.2f (Part 2 of 2)

PASSENGER MODE SWITCH SHORTED LOW: DTC B2011

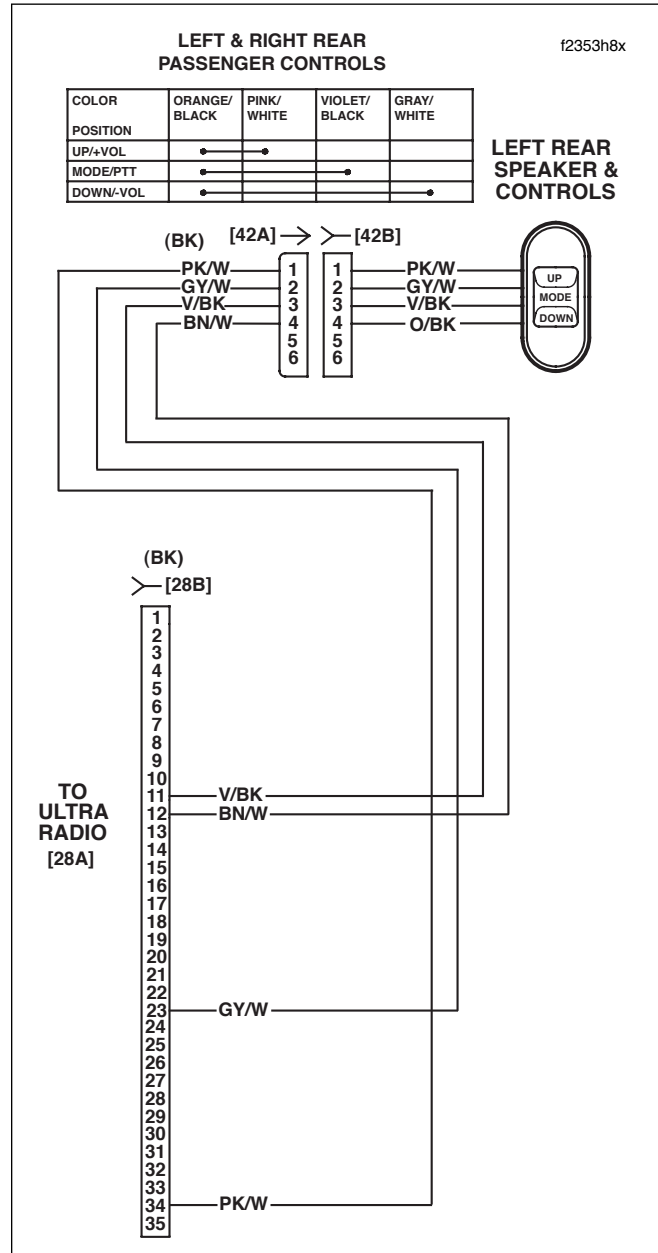
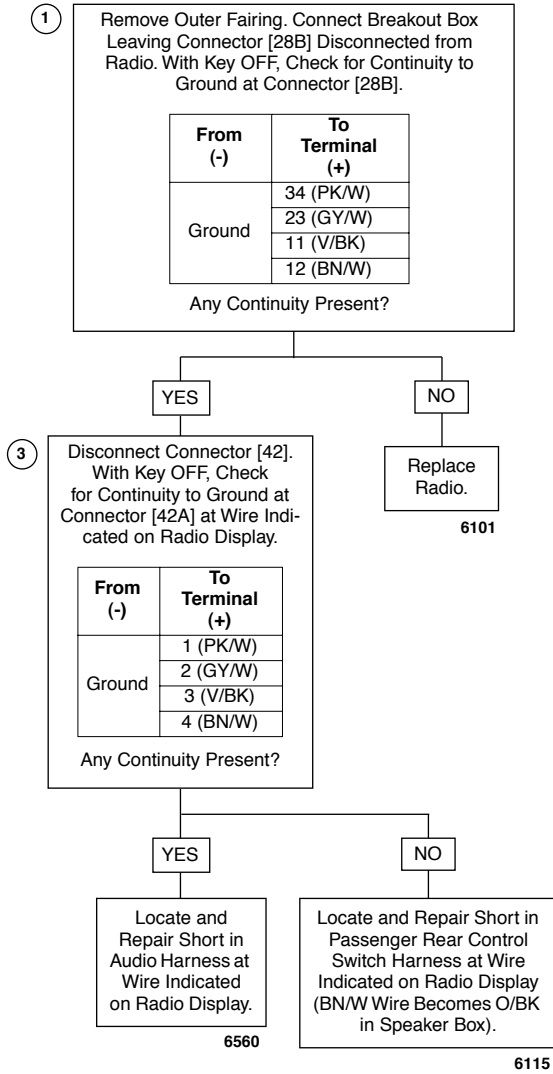

Figure 6-15. Passenger Mode Switch Circuit



Verify DTC is no longer present using radio diagnostics. See Section 6.1 RADIO DIAGNOSTICS. Confirm proper operation with no DTCs.

Table 6-15. Wire Harness Connectors

NO.	DESCRIPTION	TYPE	LOCATION
[28]	Radio	35-Place Amp	Inner Fairing- Back of Radio (Left Side)
[42]	Rear Left Speaker/Passenger Controls	6-Place Mini-Deutsch	Inside Rear Left Speaker Box

Test 6.2g (Part 1 of 2)

PASSENGER AUDIO/PTT SWITCH STUCK OR OPEN: DTC B2012

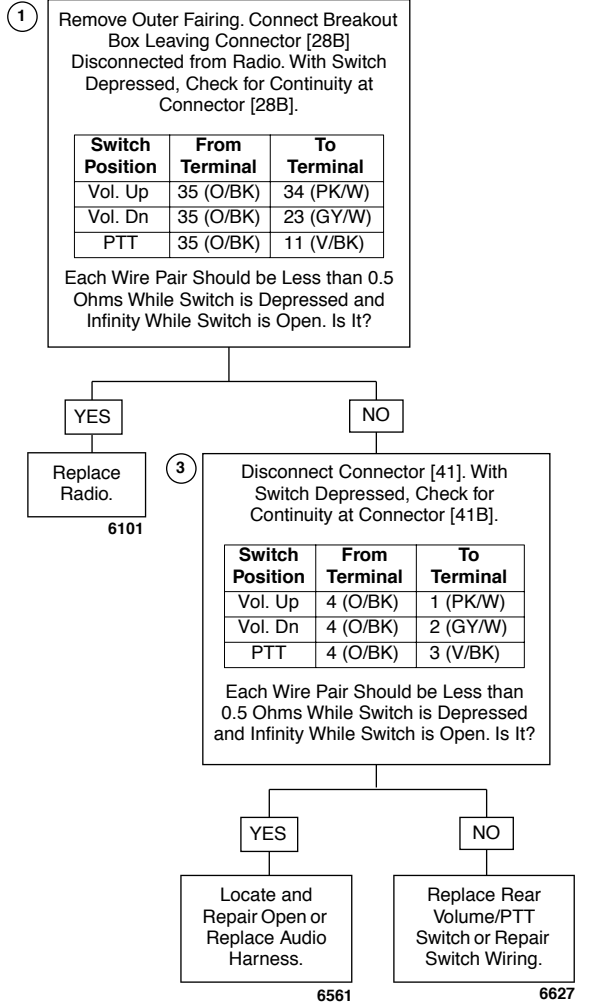

Verify DTC is no longer present using radio diagnostics. See Section 6.1 RADIO DIAGNOSTICS. Confirm proper operation with no DTCs.

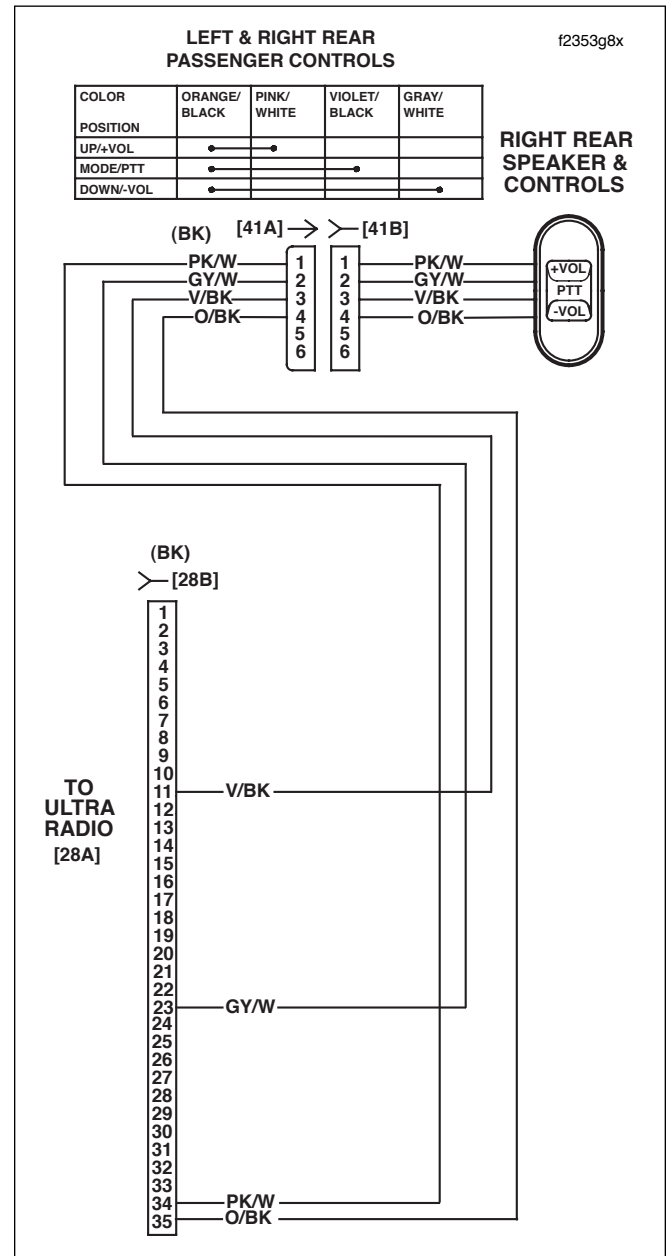

Figure 6-16. Passenger Audio/PTT Switch Circuit

Table 6-16. Wire Harness Connectors

NO.	DESCRIPTION	TYPE	LOCATION
[28]	Radio	35-Place Amp	Inner Fairing- Back of Radio (Left Side)
[41]	Rear Right Speaker/Passenger Controls	6-Place Mini-Deutsch	Inside Rear Right Speaker Box

Test 6.2g (Part 2 of 2)

PASSENGER MODE SWITCH STUCK OR OPEN: DTC B2012

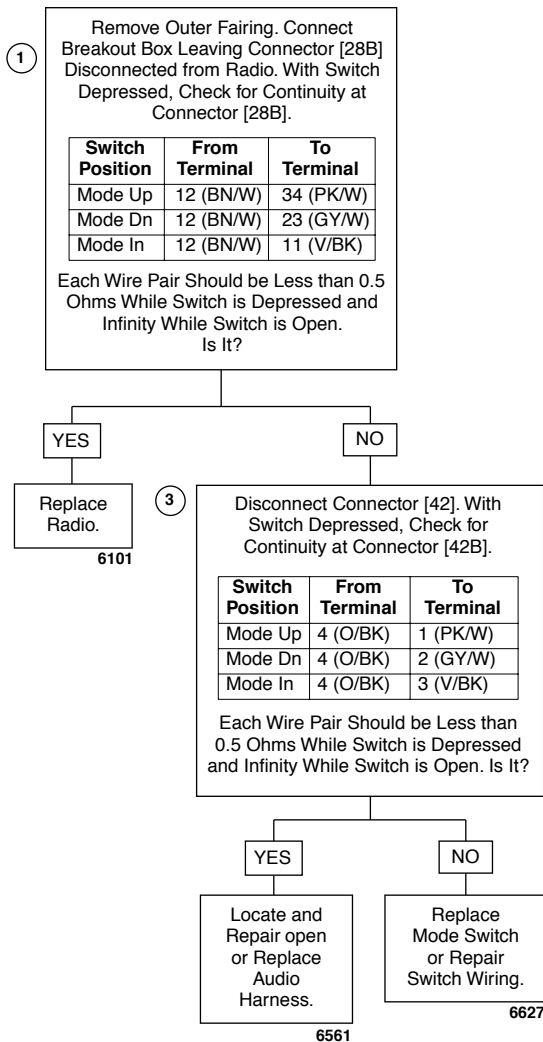

Verify DTC is no longer present using radio diagnostics. See Section 6.1 RADIO DIAGNOSTICS. Confirm proper operation with no DTCs.

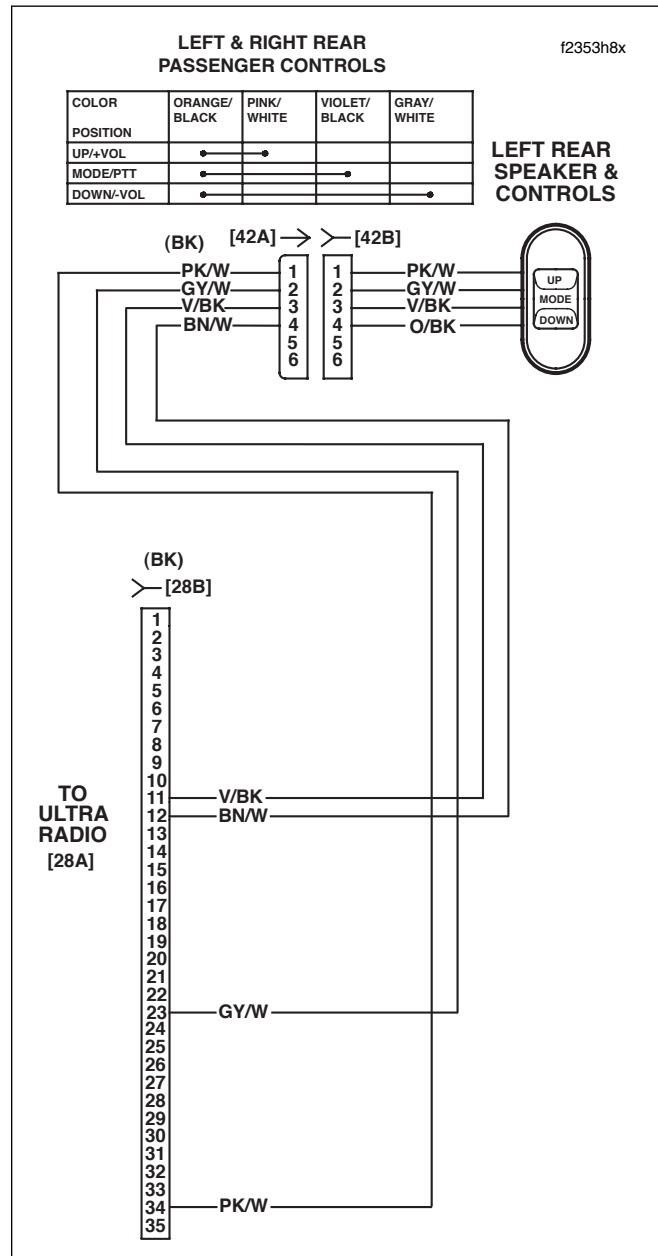

Figure 6-17. Passenger Mode Switch Circuit

Table 6-17. Wire Harness Connectors

NO.	DESCRIPTION	TYPE	LOCATION
[28]	Radio	35-Place Amp	Inner Fairing- Back of Radio (Left Side)
[42]	Rear Left Speaker/Passenger Controls	6-Place Mini-Deutsch	Inside Rear Left Speaker Box

Test 6.2h

SIDECAR SWITCHES SHORTED HIGH: DTC B2013

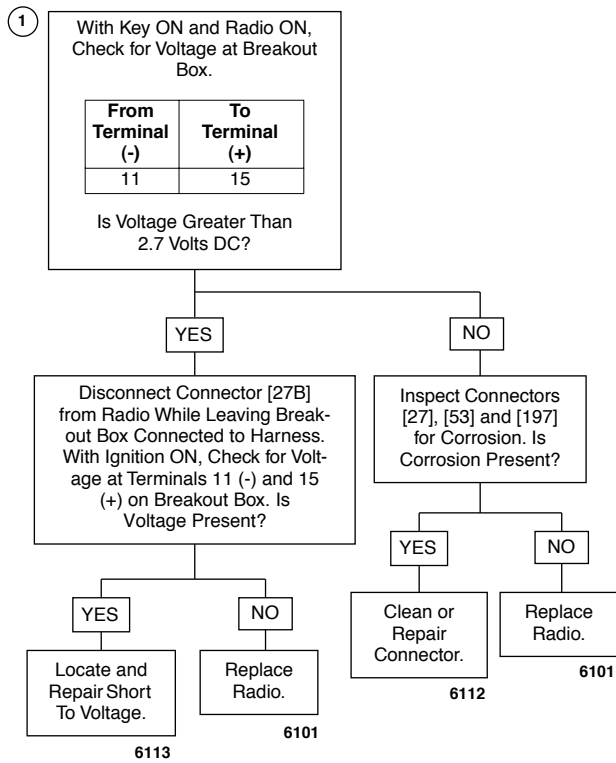

Verify DTC is no longer present using radio diagnostics. See Section 6.1 RADIO DIAGNOSTICS. Confirm proper operation with no DTCs.

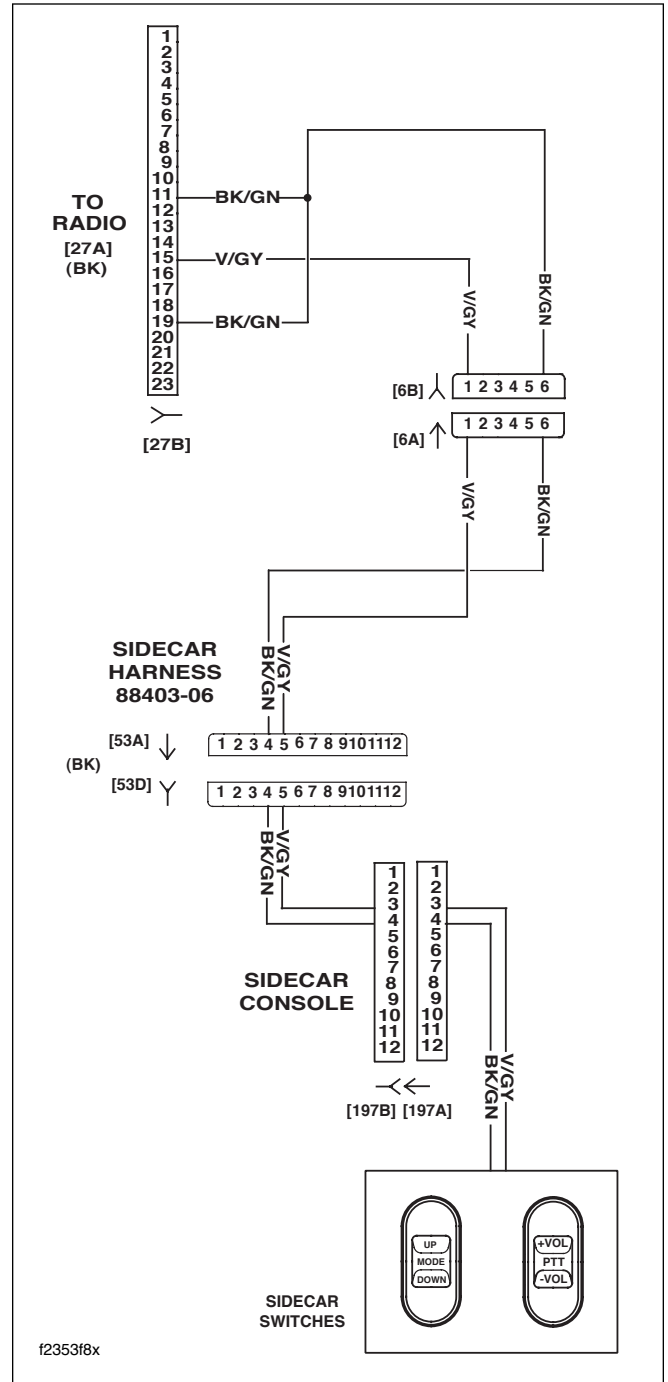

Figure 6-18. Sidecar Switch Circuit

Table 6-18. Wire Harness Connectors

NO.	DESCRIPTION	TYPE	LOCATION
[6]	Audio to Interconnect	6-Place Deutsch (Black)	Inner Fairing - Top of Radio (Left Side)
[27]	Radio	23-Place Amp	Inner Fairing- Back of Radio (Right Side)
[53]	Console Pod	12-Place Mini-Deutsch (Black)	Rear of Battery Box (Under Seat)
[197]	Sidecar Console	12-Place Mini-Deutsch (Black)	Inside Sidecar Console

Test 6.2i

SIDECAR SWITCHES SHORTED LOW: DTC B2014

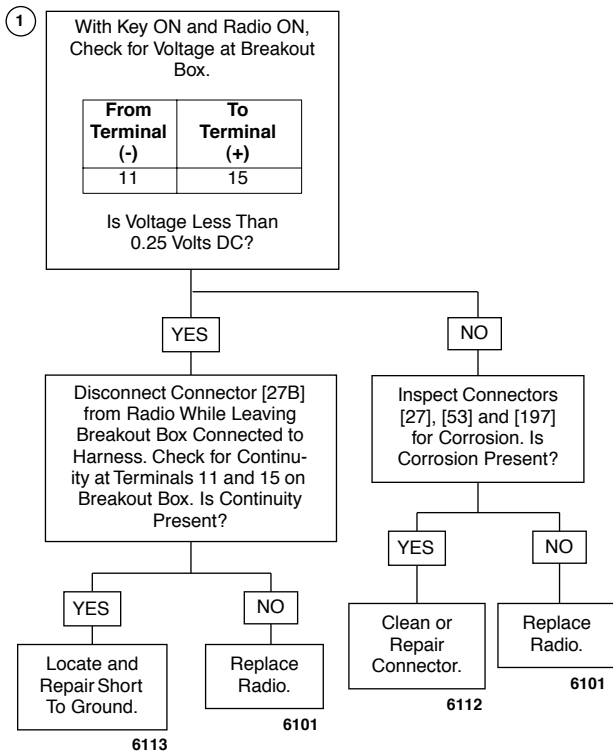

Verify DTC is no longer present using radio diagnostics. See Section 6.1 RADIO DIAGNOSTICS. Confirm proper operation with no DTCs.

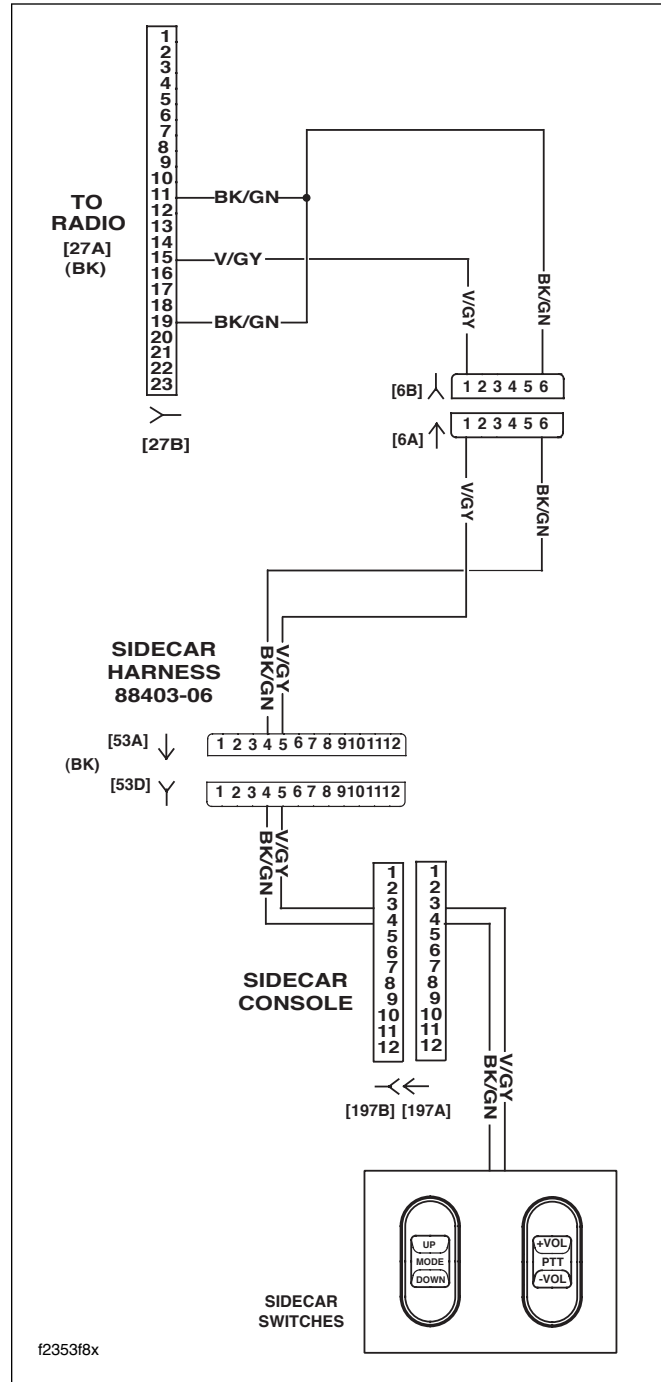

Figure 6-19. Sidecar Switch Circuit

Table 6-19. Wire Harness Connectors

NO.	DESCRIPTION	TYPE	LOCATION
[6]	Audio to Interconnect	6-Place Deutsch (Black)	Inner Fairing - Top of Radio (Left Side)
[27]	Radio	23-Place Amp	Inner Fairing- Back of Radio (Right Side)
[53]	Console Pod	12-Place Mini-Deutsch (Black)	Rear of Battery Box (Under Seat)
[197]	Sidecar Console	12-Place Mini-Deutsch (Black)	Inside Sidecar Console

Test 6.2j

SIDECAR SWITCHES STUCK OR OPEN: DTC B2015

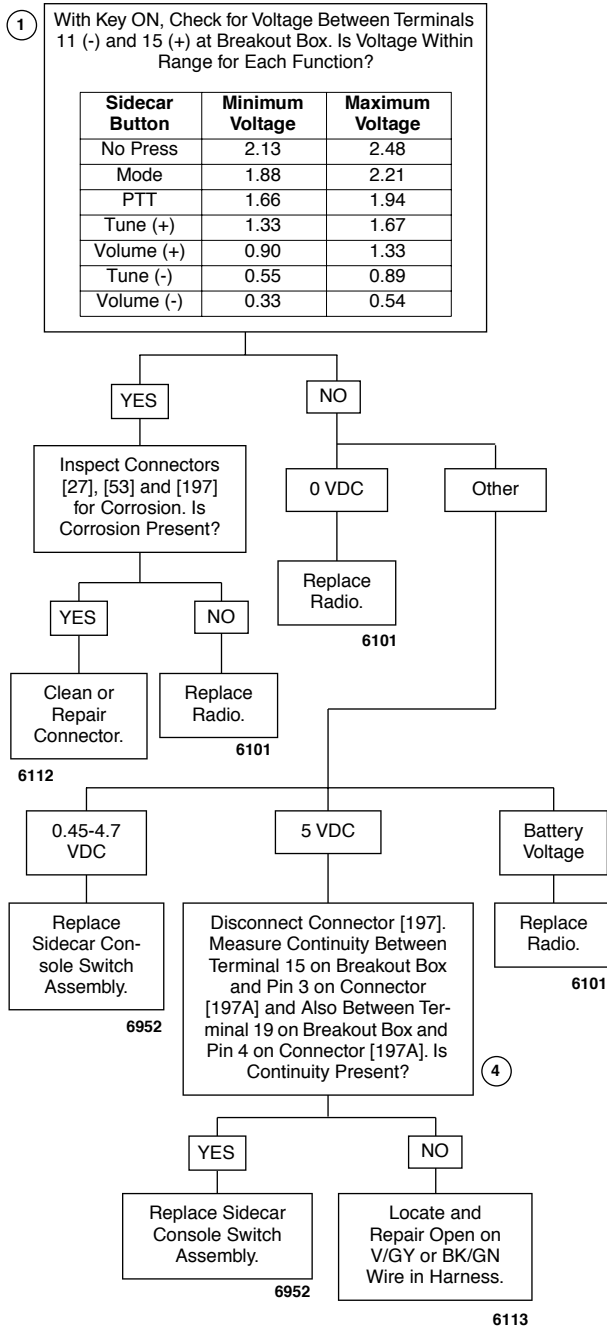

Verify DTC is no longer present using radio diagnostics. See Section 6.1 RADIO DIAGNOSTICS. Confirm proper operation with no DTCs.

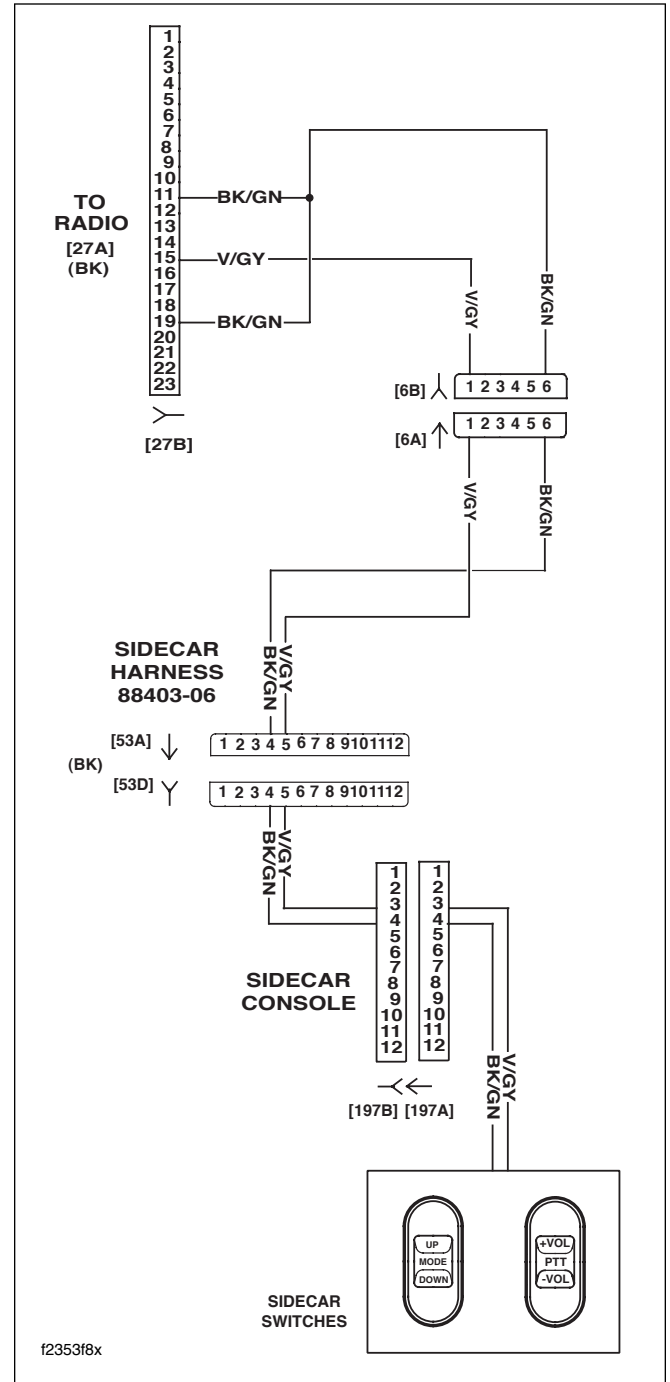

Figure 6-20. Sidecar Switch Circuit

Table 6-20. Wire Harness Connectors

NO.	DESCRIPTION	TYPE	LOCATION
[6]	Audio to Interconnect	6-Place Deutsch (Black)	Inner Fairing - Top of Radio (Left Side)
[27]	Radio	23-Place Amp	Inner Fairing- Back of Radio (Right Side)
[53]	Console Pod	12-Place Mini-Deutsch (Black)	Rear of Battery Box (Under Seat)
[197]	Sidecar Console	12-Place Mini-Deutsch (Black)	Inside Sidecar Console

GENERAL

The sound system is designed to capture faults for each of the radio speaker outputs. When a fault is detected, a DTC is generated. The DTC and related data appears on the radio display when the system is in the diagnostic mode.

Table 6-21. Code Description

DTC	DESCRIPTION
B2016	Front speakers shorted
B2017	Front speakers open
B2018	Front speakers shorted to ground
B2019	Front speakers shorted to battery
B2020	Rear speakers shorted
B2021	Rear speakers open
B2022	Rear speakers shorted to ground
B2023	Rear speakers shorted to battery
B2024	Sidecar speakers shorted
B2025	Sidecar speakers open
B2026	Sidecar speakers shorted to ground
B2027	Sidecar speakers shorted to battery

DIAGNOSTICS

Diagnostic Notes

The reference numbers below correlate with the circled numbers on the [Test 6.3a](#) thru [Test 6.3l](#) flow charts.

1. Install RADIO BREAKOUT BOX (Part No. HD-47918).

Test 6.3a

FRONT SPEAKERS SHORTED: DTC B2016

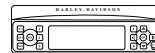
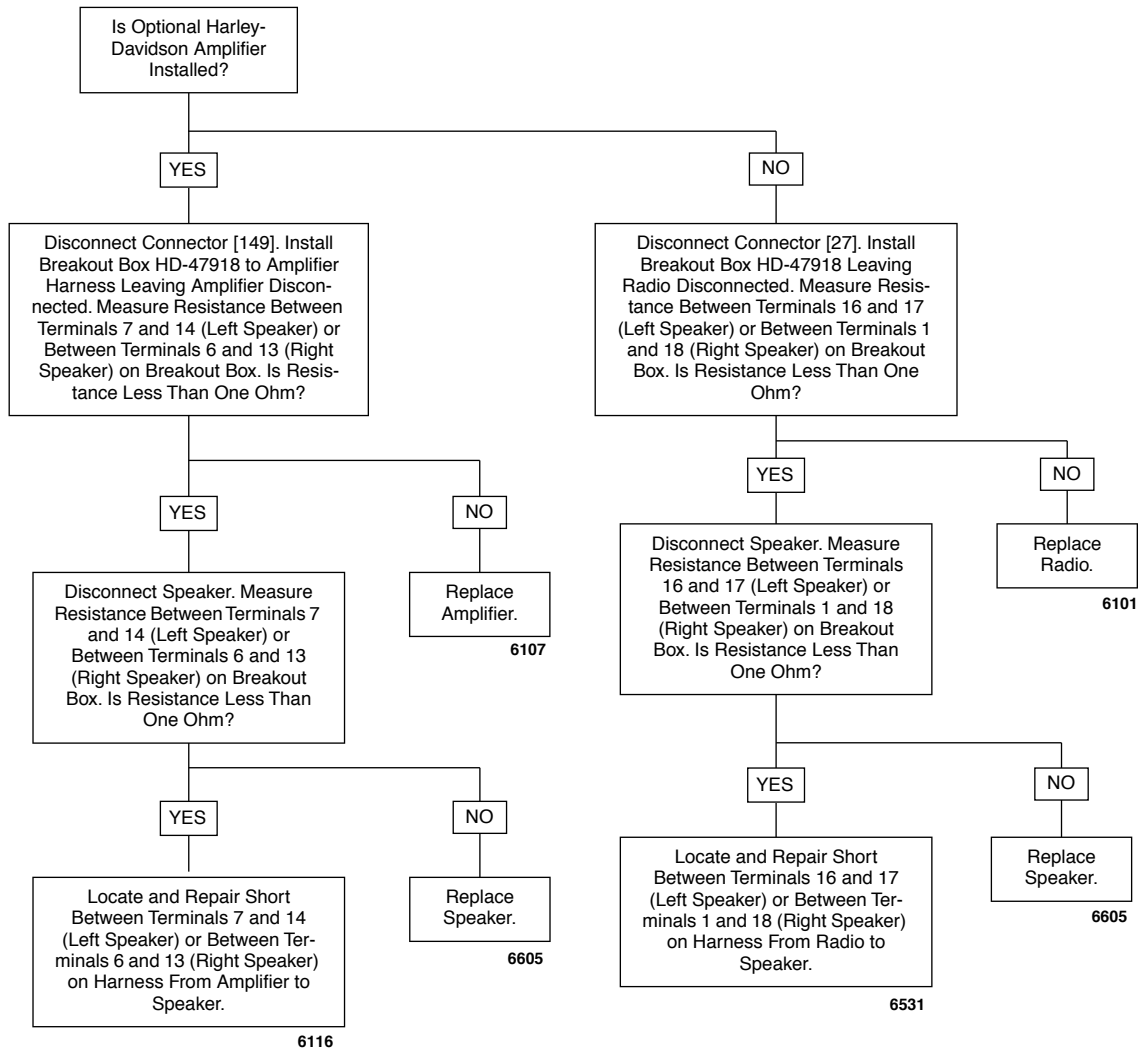

Verify DTC is no longer present using radio diagnostics. See Section 6.1 RADIO DIAGNOSTICS. Confirm proper operation with no DTCs.

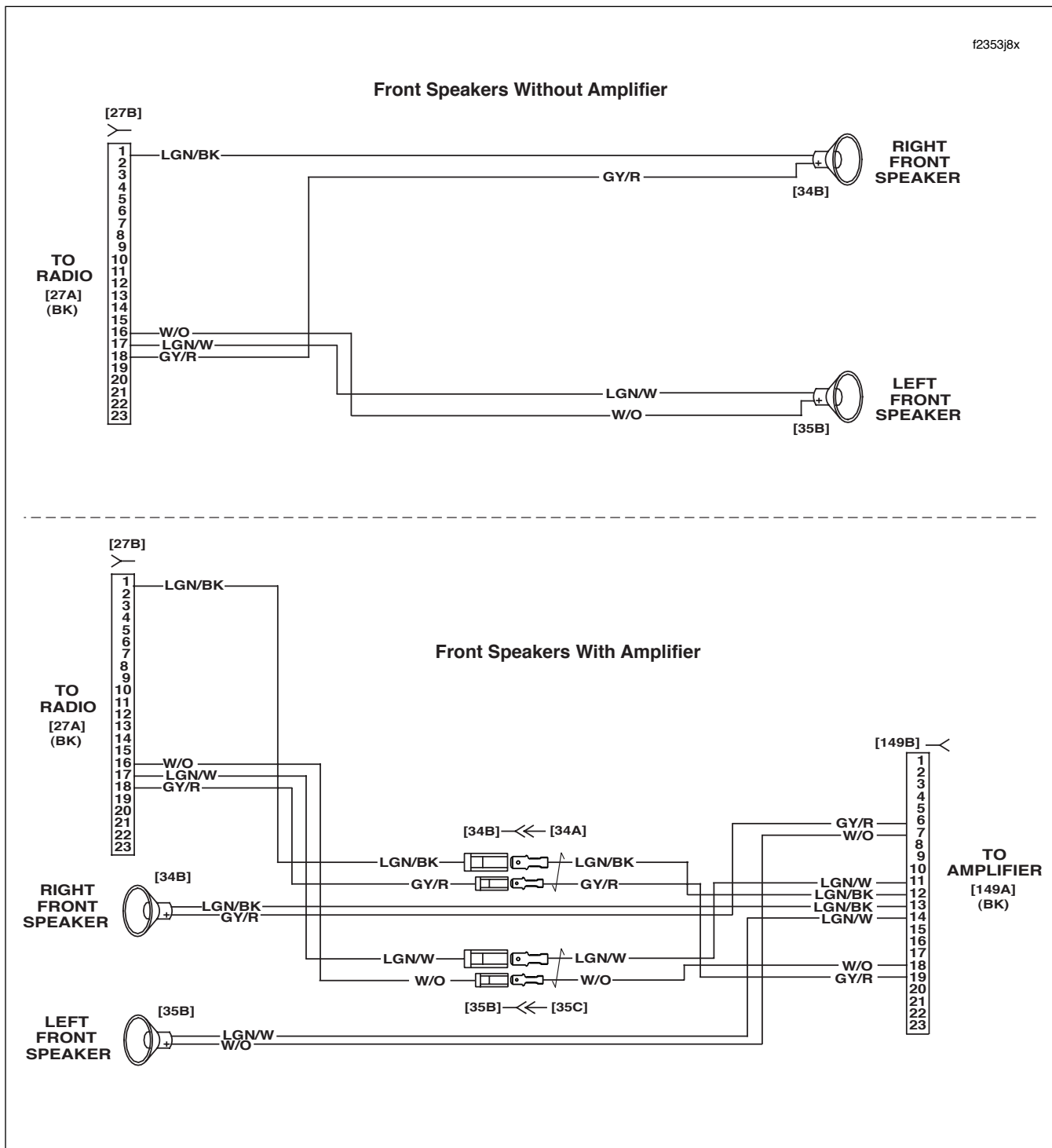

Figure 6-21. Front Speaker Circuit

Table 6-22. Wire Harness Connectors

NO.	DESCRIPTION	TYPE	LOCATION
[27]	Radio	23-Place Amp	Inner Fairing- Back of Radio (Right Side)
[34]	Front Right Speaker	Spade Contacts	Inner Fairing - Back of Right Speaker
[35]	Front Left Speaker	Spade Contacts	Inner Fairing - Back of Left Speaker
[149]	High Output Amplifier	23-Place Amp	Under Luggage Rack (Right Side)

Test 6.3b

FRONT SPEAKERS OPEN: DTC B2017

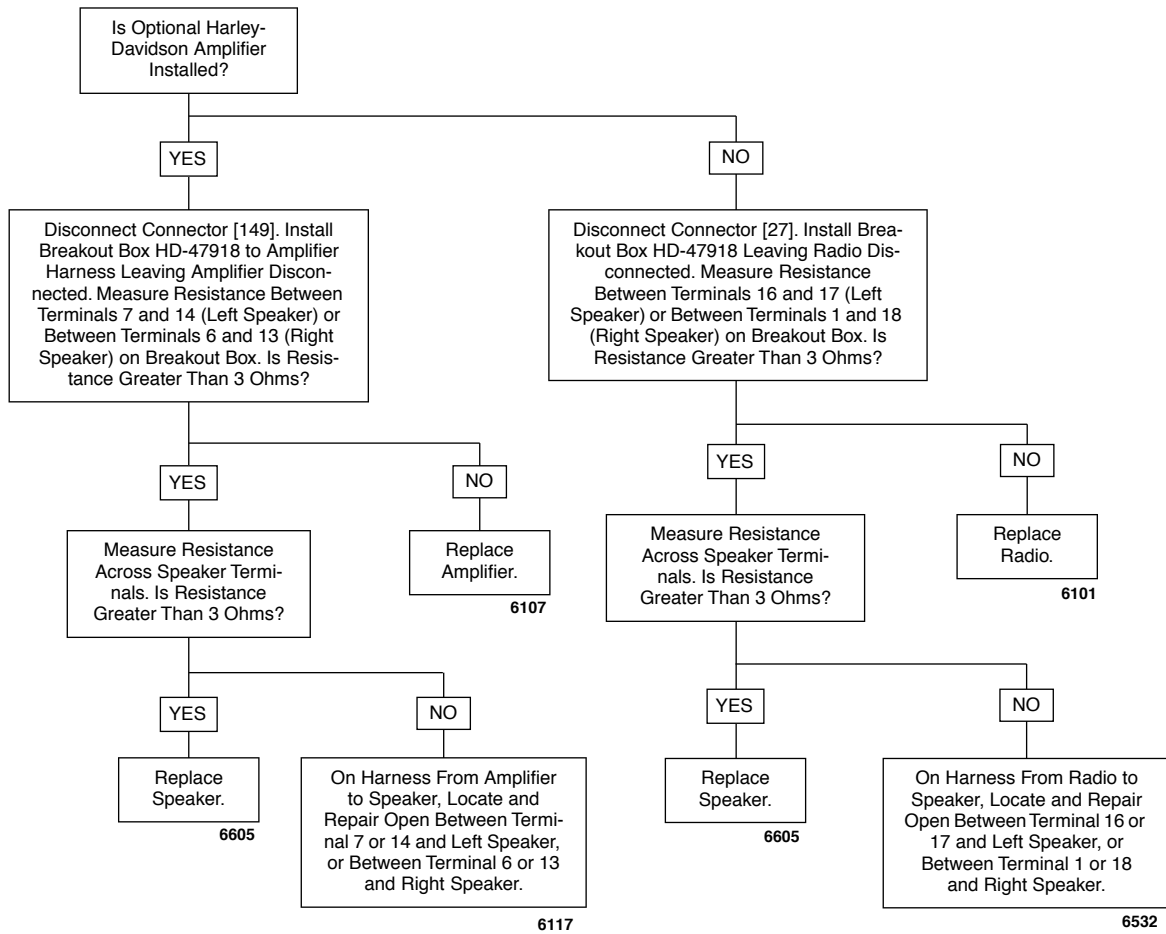

Verify DTC is no longer present using radio diagnostics. See Section 6.1 RADIO DIAGNOSTICS. Confirm proper operation with no DTCs.

Test 6.3c

FRONT SPEAKERS SHORTED TO GROUND: DTC B2018

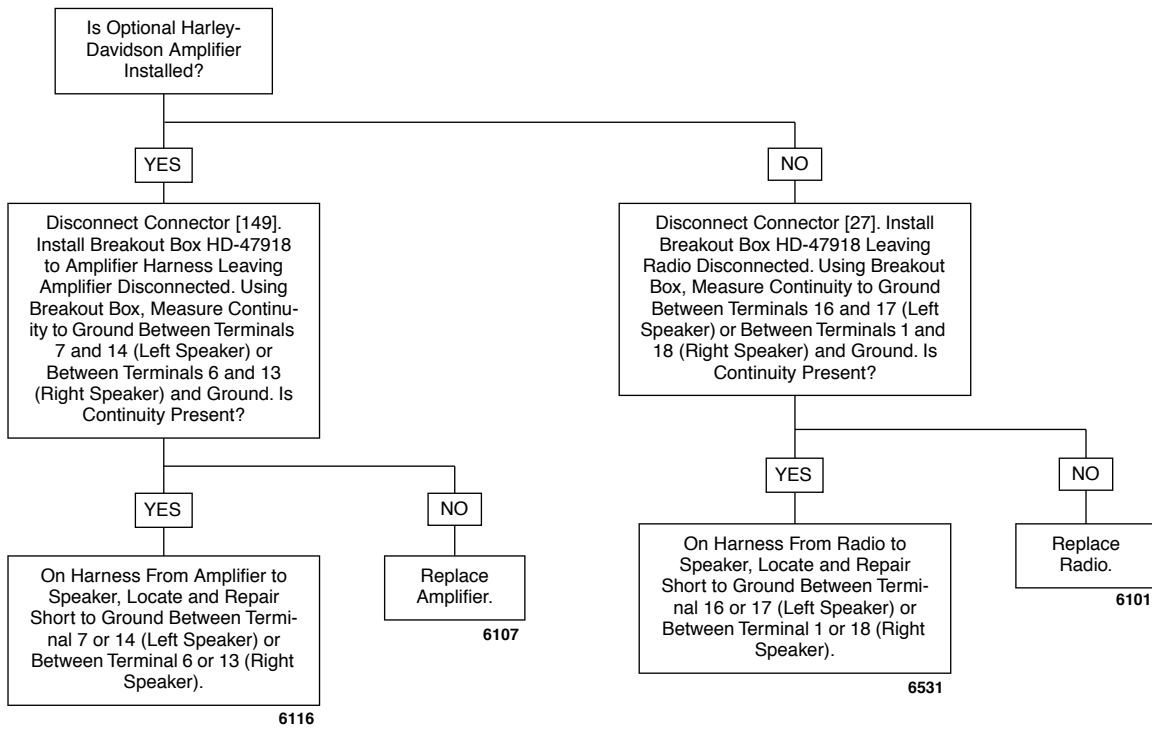

Verify DTC is no longer present using radio diagnostics. See Section 6.1 RADIO DIAGNOSTICS. Confirm proper operation with no DTCs.

Test 6.3d

FRONT SPEAKERS SHORTED TO BATTERY: DTC B2019

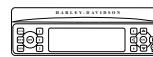
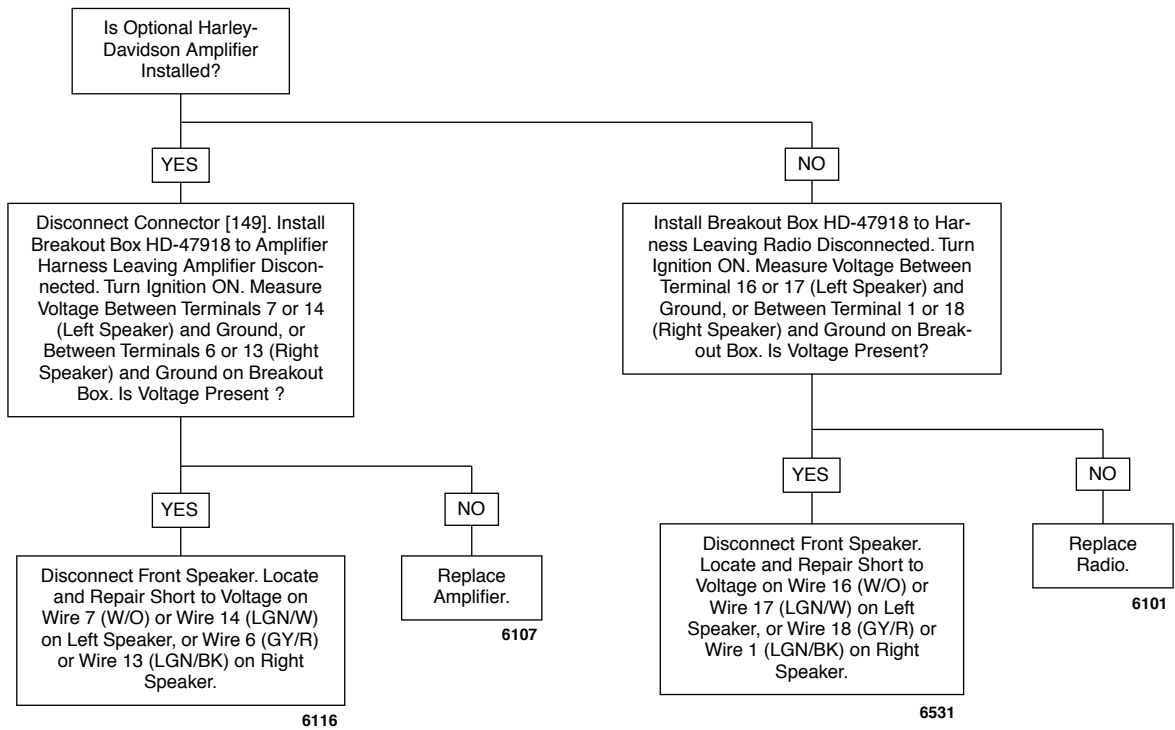

Verify DTC is no longer present using radio diagnostics. See Section 6.1 RADIO DIAGNOSTICS. Confirm proper operation with no DTCs.

Test 6.3e

REAR SPEAKERS SHORTED: DTC B2020

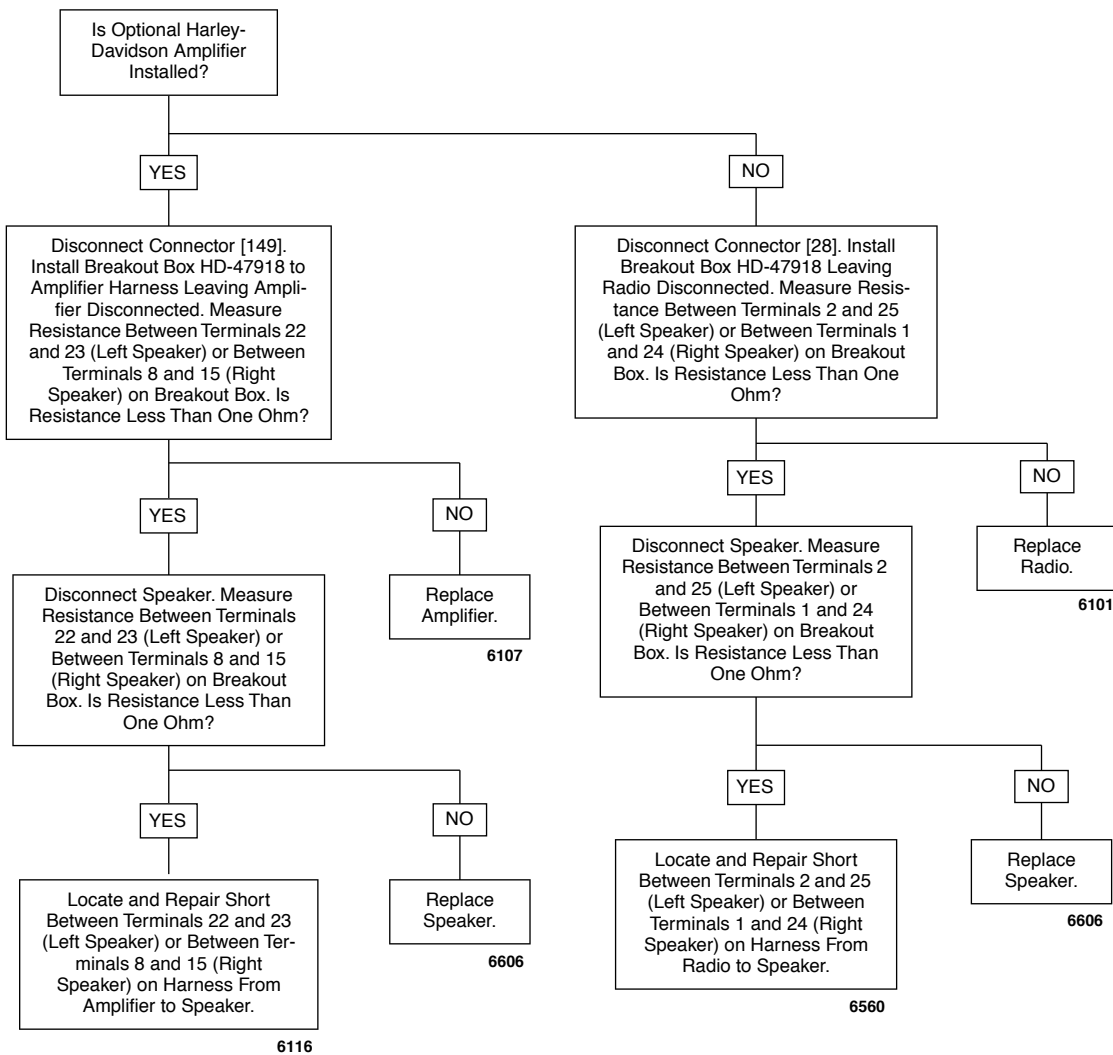

Verify DTC is no longer present using radio diagnostics. See Section 6.1 RADIO DIAGNOSTICS. Confirm proper operation with no DTCs.

Table 6-23. Wire Harness Connectors

NO.	DESCRIPTION	TYPE	LOCATION
[28]	Radio	35-Place Amp	Inner Fairing - Back of Radio (Left Side)
[36]	Rear Right Speaker	Spade Contacts	Inside Rear Right Speaker Box
[37]	Rear Left Speaker	Spade Contacts	Inside Rear Left Speaker Box
[41]	Rear Right Speaker/Passenger Controls	6-Place Mini-Deutsch	Inside Rear Right Speaker Box
[42]	Rear Left Speaker/Passenger Controls	6-Place Mini-Deutsch	Inside Rear Left Speaker Box
[149]	High Output Amplifier	23-Place Amp	Under Luggage Rack (Right Side)

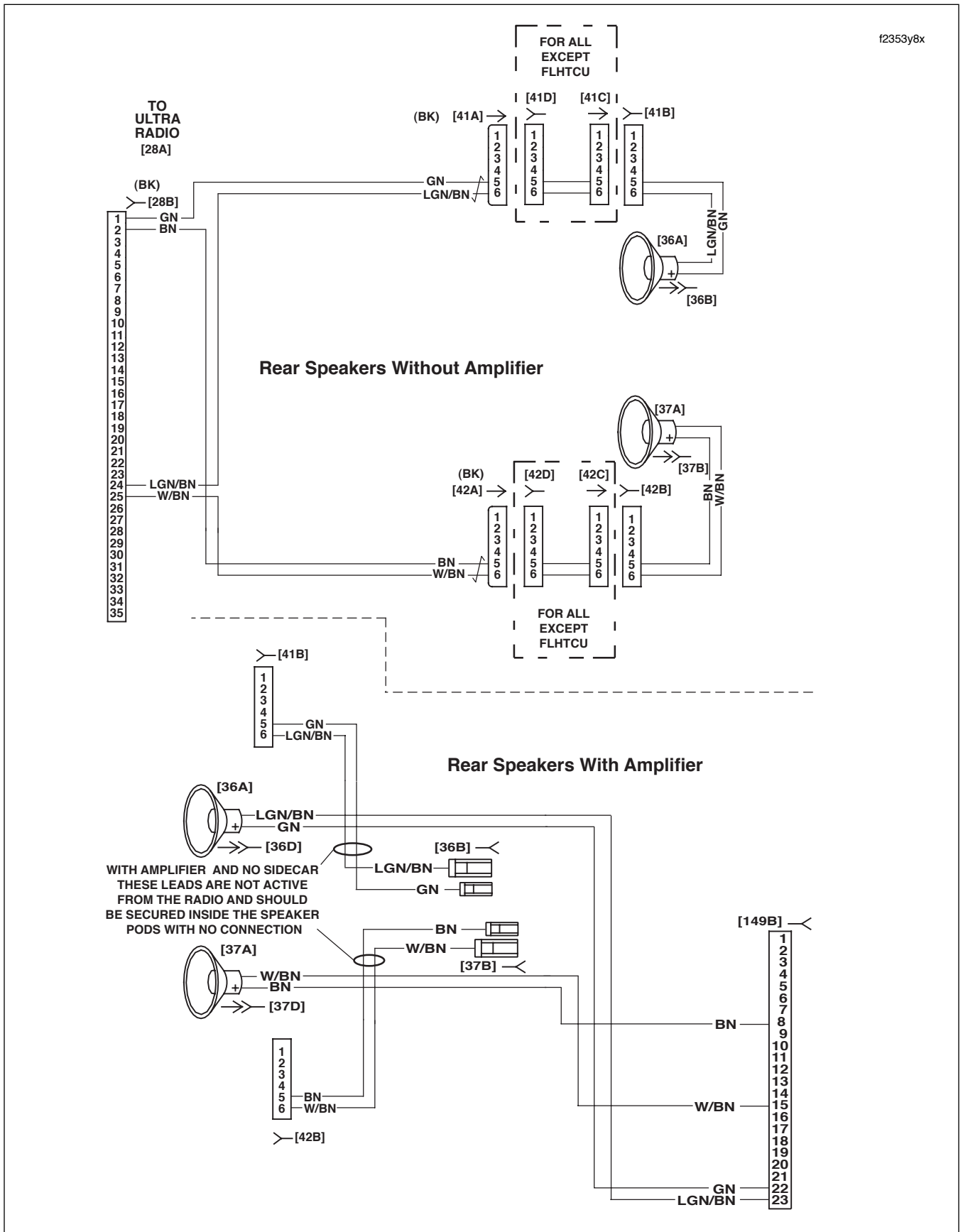
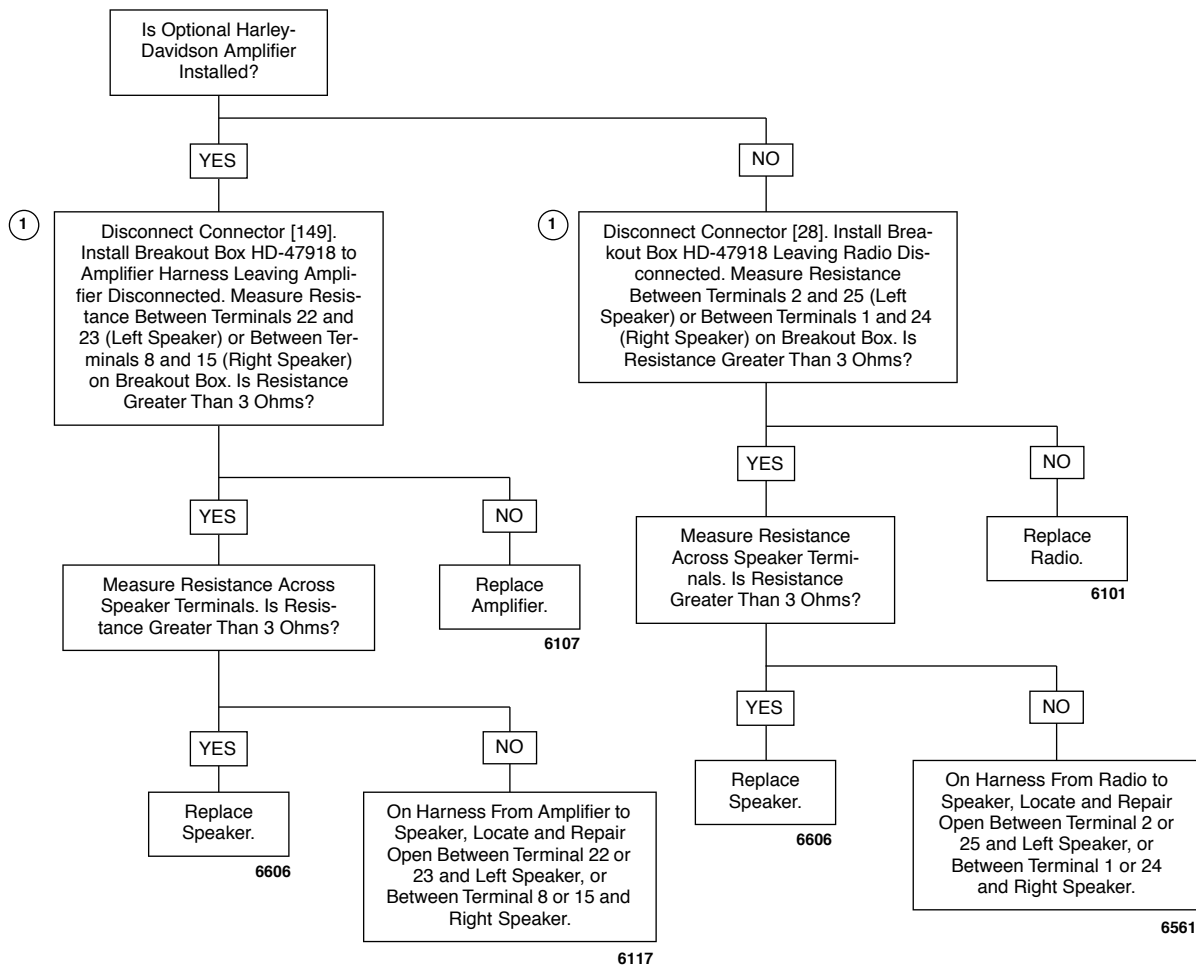

Figure 6-22. Rear Speaker Circuit

Test 6.3f

REAR SPEAKERS OPEN: DTC B2021



Verify DTC is no longer present using radio diagnostics. See Section 6.1 RADIO DIAGNOSTICS. Confirm proper operation with no DTCs.

Test 6.3g

REAR SPEAKERS SHORTED TO GROUND: DTC B2022

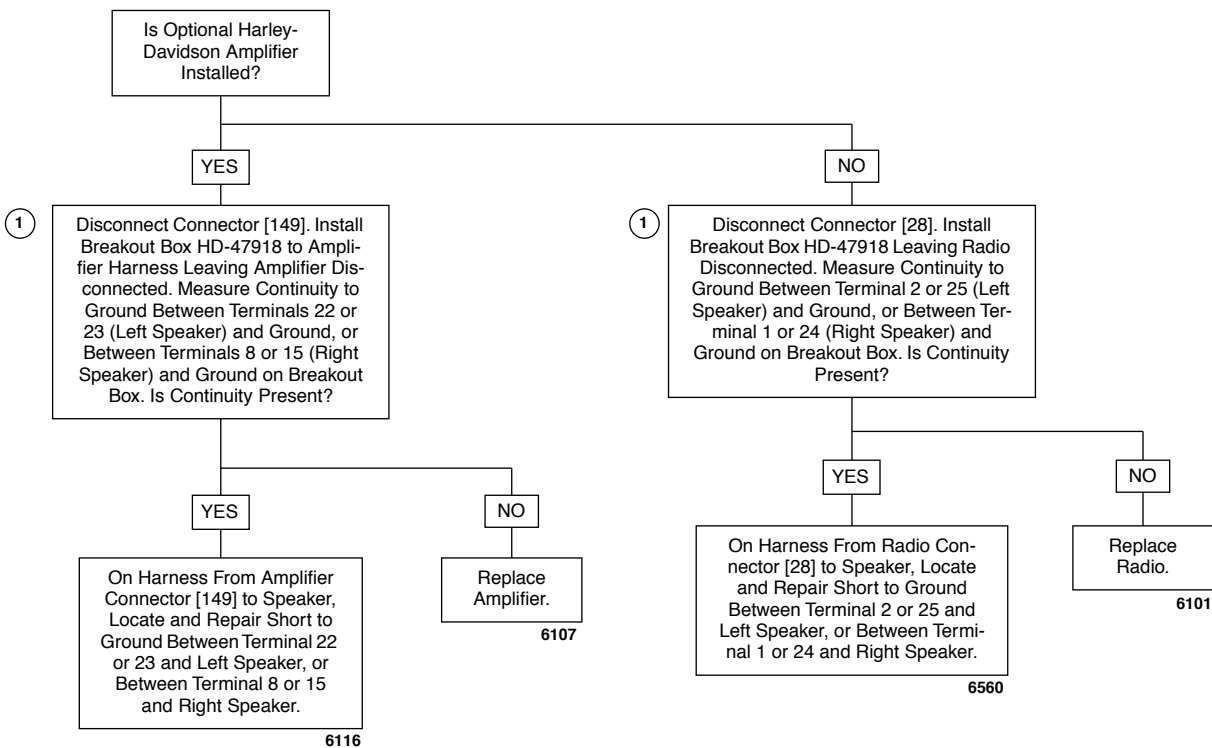

Verify DTC is no longer present using radio diagnostics. See Section 6.1 RADIO DIAGNOSTICS. Confirm proper operation with no DTCs.

Test 6.3h

REAR SPEAKERS SHORTED TO BATTERY: DTC B2023

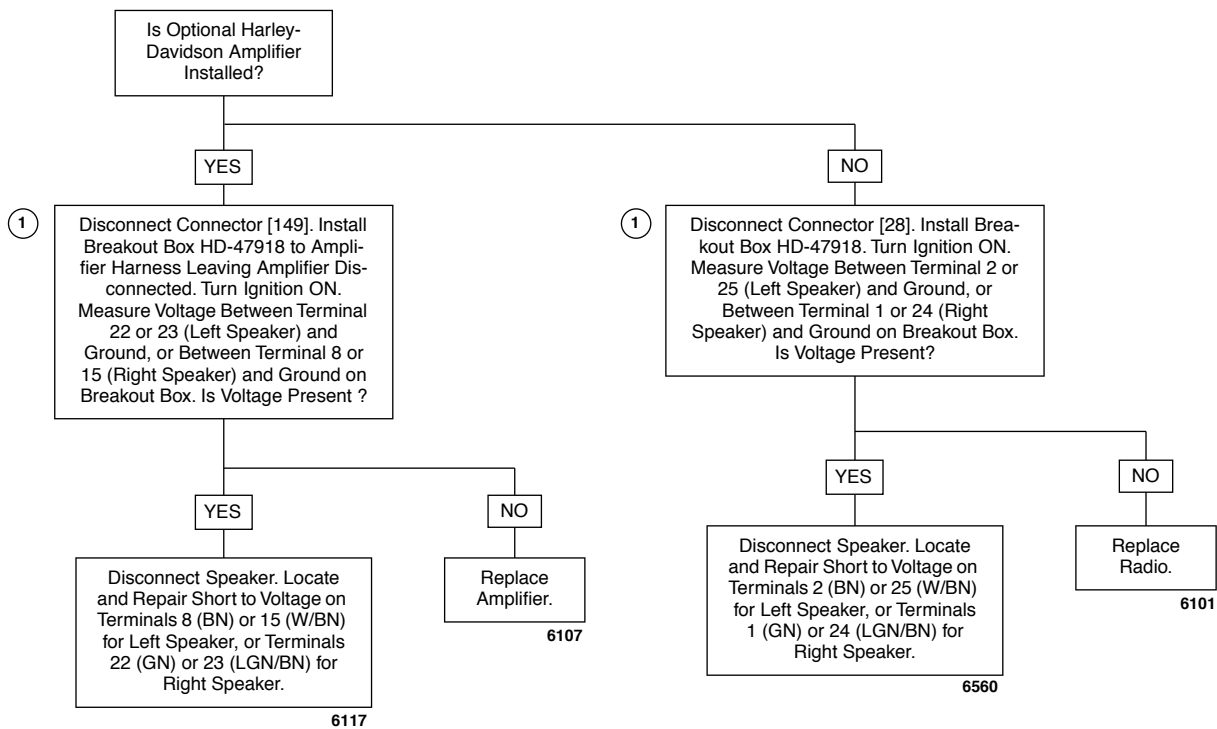

Verify DTC is no longer present using radio diagnostics. See Section 6.1 RADIO DIAGNOSTICS. Confirm proper operation with no DTCs.

Test 6.3i

SIDECAR SPEAKERS SHORTED: DTC B2024

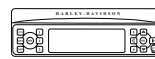
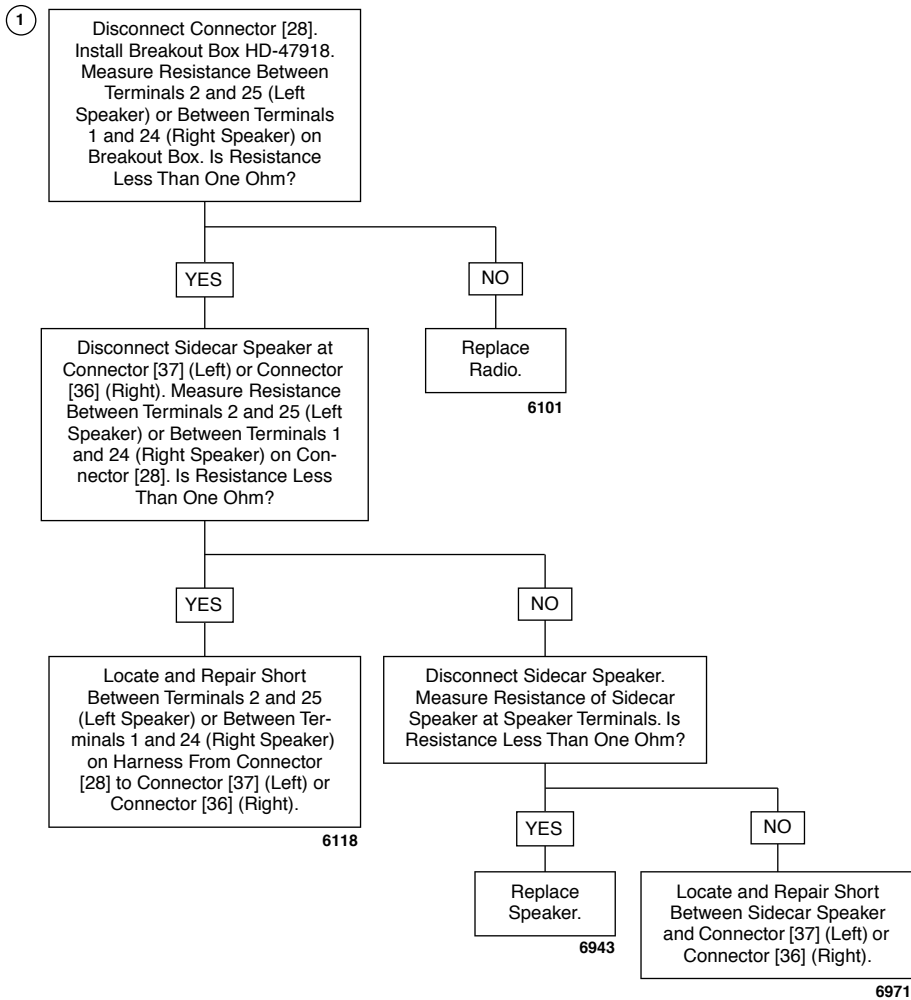

Verify DTC is no longer present using radio diagnostics. See Section 6.1 RADIO DIAGNOSTICS. Confirm proper operation with no DTCs.

Table 6-24. Wire Harness Connectors

NO.	DESCRIPTION	TYPE	LOCATION
[28]	Radio	35-Place Amp	Inner Fairing - Back of Radio (Left Side)
[36]	Rear Right Speaker	Spade Contacts	Inside Rear Right Speaker Box
[37]	Rear Left Speaker	Spade Contacts	Inside Rear Left Speaker Box
[41]	Rear Right Speaker/Passenger Controls	6-Place Mini-Deutsch	Inside Rear Right Speaker Box
[42]	Rear Left Speaker/Passenger Controls	6-Place Mini-Deutsch	Inside Rear Left Speaker Box
[197]	Sidecar Console	12-Place Mini-Deutsch	Inside Sidecar Console

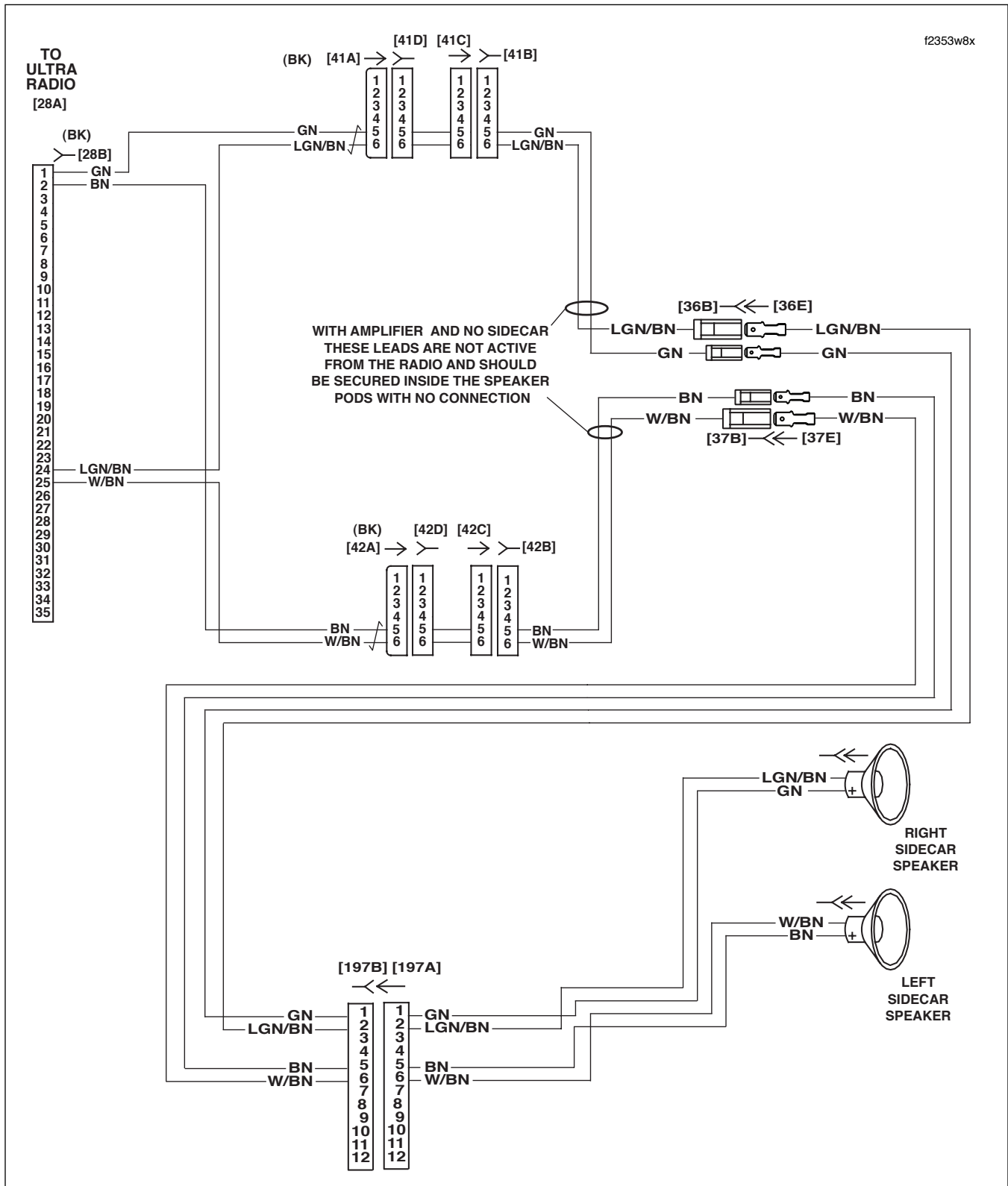
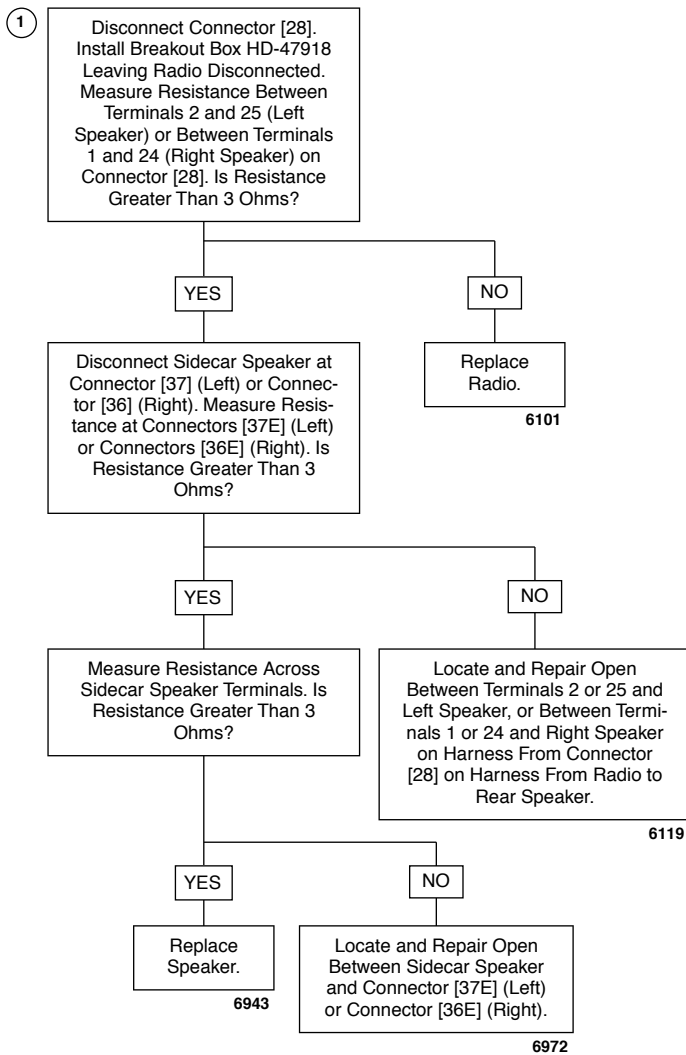

Figure 6-23. Sidecar Speaker Circuit

Test 6.3j

SIDECAR SPEAKERS OPEN: DTC B2025



Verify DTC is no longer present using radio diagnostics. See Section 6.1 RADIO DIAGNOSTICS. Confirm proper operation with no DTCs.

Test 6.3k

SIDECAR SPEAKERS SHORTED TO GROUND: DTC B2026

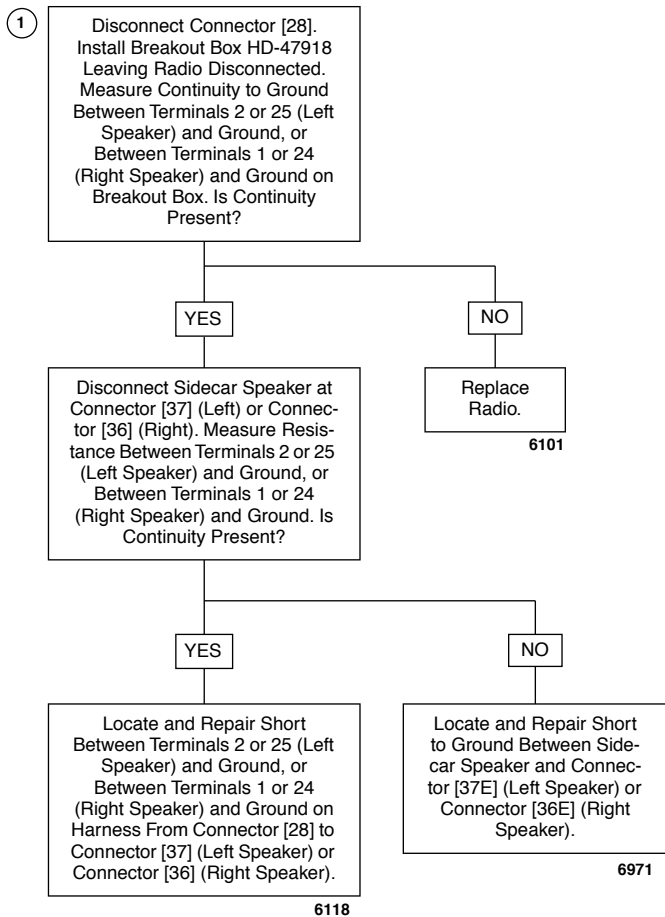

Verify DTC is no longer present using radio diagnostics. See Section 6.1 RADIO DIAGNOSTICS. Confirm proper operation with no DTCs.

Test 6.3I

SIDECAR SPEAKERS SHORTED TO BATTERY: DTC B2027

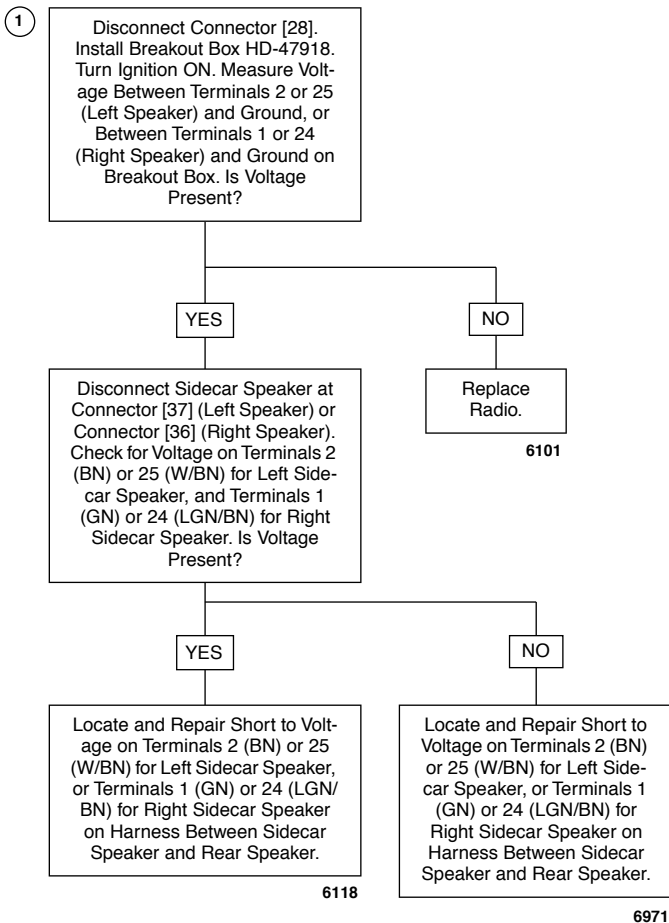

Verify DTC is no longer present using radio diagnostics. See Section 6.1 RADIO DIAGNOSTICS. Confirm proper operation with no DTCs.

GENERAL

There are two serial data BUS's. The first one is the J1850 serial data BUS which communicates between the radio and the ECM, TSSM and instruments. The second serial data BUS is the Infotainment BUS, which uses a CAN protocol to communicate between the radio and the other radio accessories. The radio captures any errors found on both serial data BUS's and stores them as DTCs.

Table 6-25. J1850 Serial Data BUS

DTC	DESCRIPTION
U1016	J1850 lost communications with ECM/ICM
U1300	J1850 bus shorted low
U1301	J1850 bus shorted high

Table 6-26. Infotainment BUS

DTC	DESCRIPTION
U1302	Infotainment bus shorted low/high
U1306	Infotainment bus lost communications with hands free phone module
U1307	Infotainment bus lost communications with CB
U1308	Infotainment bus lost communications with future
U1312	Infotainment bus lost communications with future
U1313	Infotainment bus lost communications with XM
U1314	Infotainment bus lost communications with navigation
U1317	Infotainment bus lost communications with high output amplifier

LOSS OF SERIAL DATA: DTC U1016

The serial data connector provides a means for the ICM or ECM, TSM/TSSM and speedometer to communicate their current status. When all operating parameters on the serial data bus are within specifications, a state of health message is sent between the components. A diagnostic trouble code (DTC) U1016 indicates that the ICM/ECM is not capable of sending this state of health message.

STARTS, THEN STALLS: DTC U1300, U1301

The typical serial data voltage range is 0 volts (inactive) to 7 volts (active). Due to the short pulse, voltages will be much lower on a DVOM. In analog mode, a DVOM reading serial data will show continuous voltage when active, typically 0.6-0.8 volts. The range for acceptable operations is greater than 0 and less than 7.0 volts.

NOTE

Problems in the fuel system or idle air control system may also create this symptom.

Diagnostic Tips

- If serial data is shorted, these codes will automatically trip the check engine light.
- DTCs P1009 and P1010 may accompany DTCs U1300 and U1301.
- If radio ground **and** antenna ground are open, a serial data BUS fault may occur causing a start and stall condition.

DIAGNOSTICS

Diagnostic Notes

The reference numbers below correlate with the circled numbers on the [Test 6.4a](#) thru [Test 6.4h](#) flow charts.

1. Install RADIO BREAKOUT BOX (Part No. HD-47918).
2. Connect BREAKOUT BOX (Part No. HD-42682) (black) between ICM connector [10A] and wiring harness connector [10B]. See [4.6 BREAKOUT BOX: ICM](#)
3. Connect BREAKOUT BOX (Part No. HD-43876) between wire harness and ECM. See [5.7 BREAKOUT BOX: EFI](#).
4. Use HARNESS CONNECTOR TEST KIT (Part No. HD-41404A), black socket probes and patch cord.
5. This 18-place connector is located on the hands free phone module. Disconnect the connector and GENTLY touch the probes to the terminals to make the measurement. Do not insert probe into connector.
6. The amplifier fuse is an inline fuse for all accessory installations and is mounted in the fuse block for FLHT-CUSE models.

Test 6.4a

LOSS OF SERIAL DATA: DTC U1016

NOTE
See *Diagnostic Notes* on Page 6-42.

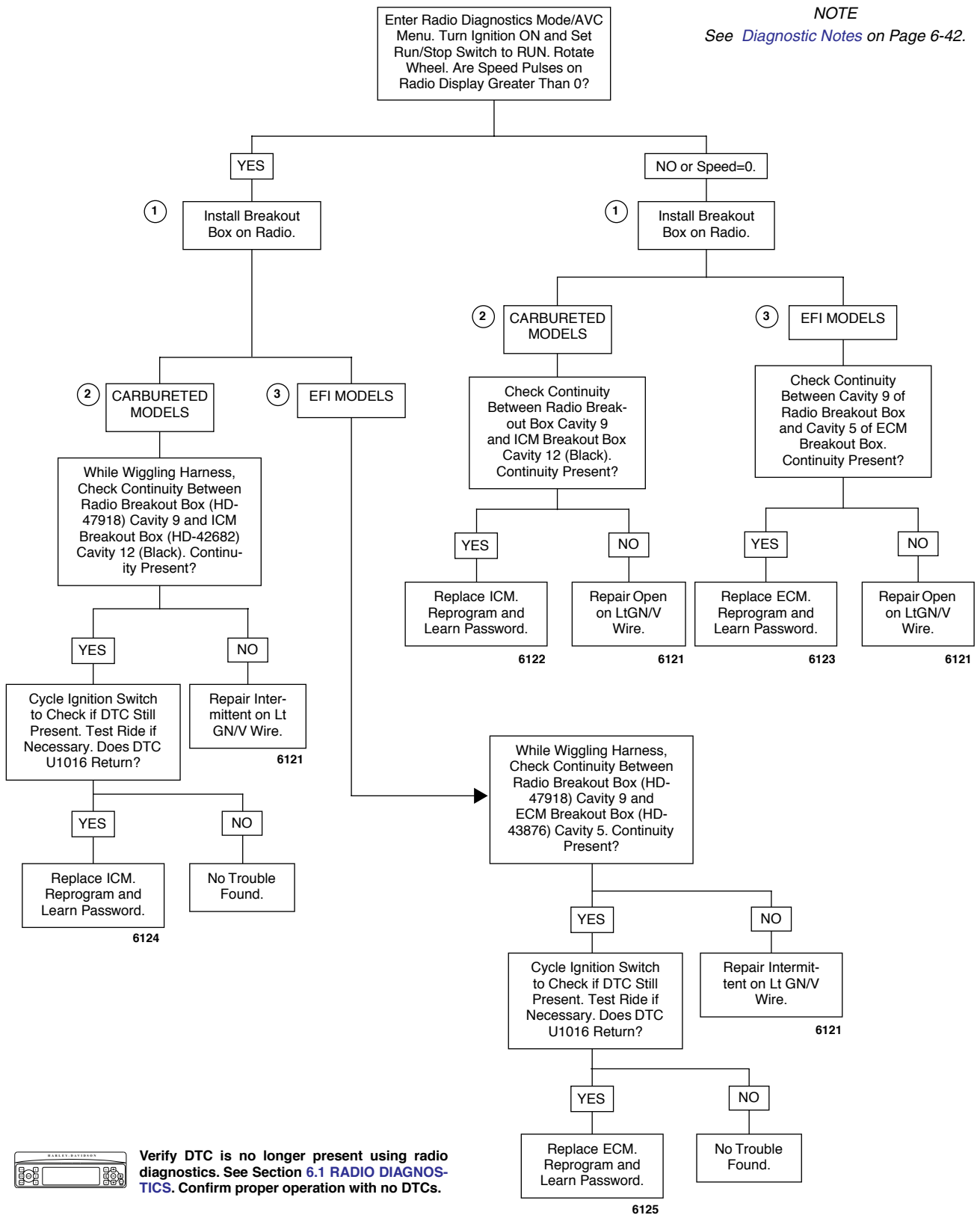

Verify DTC is no longer present using radio diagnostics. See Section 6.1 RADIO DIAGNOSTICS. Confirm proper operation with no DTCs.

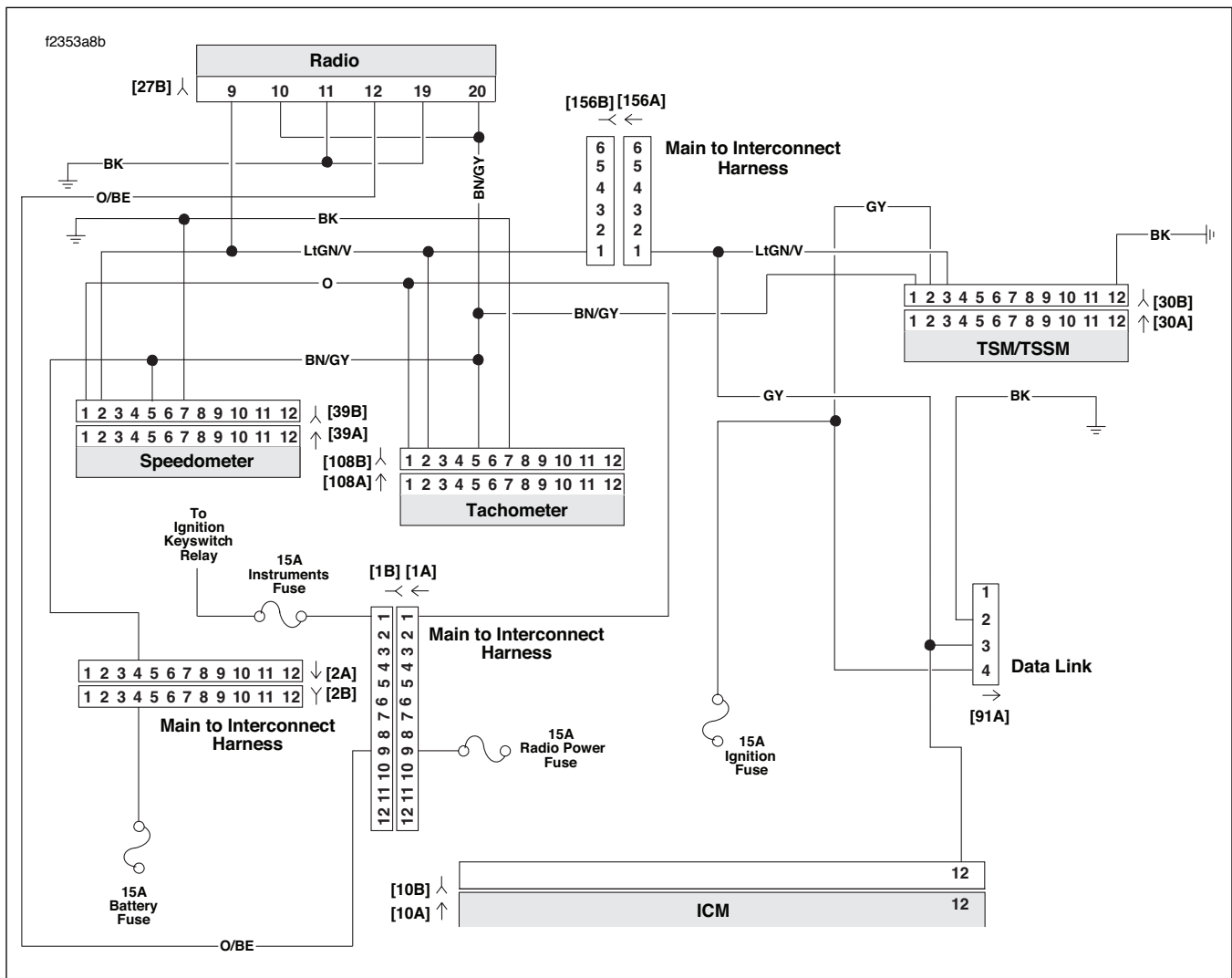

Figure 6-24. Serial Data Circuit: FLHX, FLHT/C (Carbureted)

Table 6-27. Wire Harness Connectors

NO.	DESCRIPTION	MODEL	TYPE	LOCATION
[1]	Main to Interconnect Harness	FLHX, FLHTC/U	12-Place Deutsch (Black)	Inner Fairing - Right Radio Support Bracket
		FLTR	12-Place Deutsch (Black)	Inner Fairing - Below Radio (Right Side)
[2]	Main to Interconnect Harness	FLHX, FLHTC/U	12-Place Deutsch (Gray)	Inner Fairing - Right Fairing Support Brace
		FLTR	12-Place Deutsch (Gray)	Inner Fairing - Below Radio (Right Side)
[10]	ICM	All	12-Place Deutsch	Under Right Side Cover
[27]	Radio	All	23-Place Amp (Black)	Inner Fairing - Back of Radio (Right Side)
[30]	TSM/TSSM	All	12-Place Deutsch	Cavity in Crossmember at Rear of Battery Box (Under Seat)
[39]	Speedometer	FLHX, FLHTC/U	12-Place Packard	Inner Fairing (Back of Speedometer)
		FLTR	12-Place Packard	Under Bezel (Back of Speedometer)
[91]	Data Link	All	4-Place Deutsch	Under Right Side Cover
[108]	Tachometer	FLHX, FLHTC/U	12-Place Packard	Inner Fairing (Back of Tachometer)
		FLTR	12-Place Packard	Under Bezel (Back of Tachometer)
[156]	Main to Interconnect Harness	FLHX, FLHTC/U	6-Place Deutsch	Inner Fairing - Right Fairing Support Brace
		FLTR	6-Place Deutsch	Inner Fairing - Below Radio (Right Side)

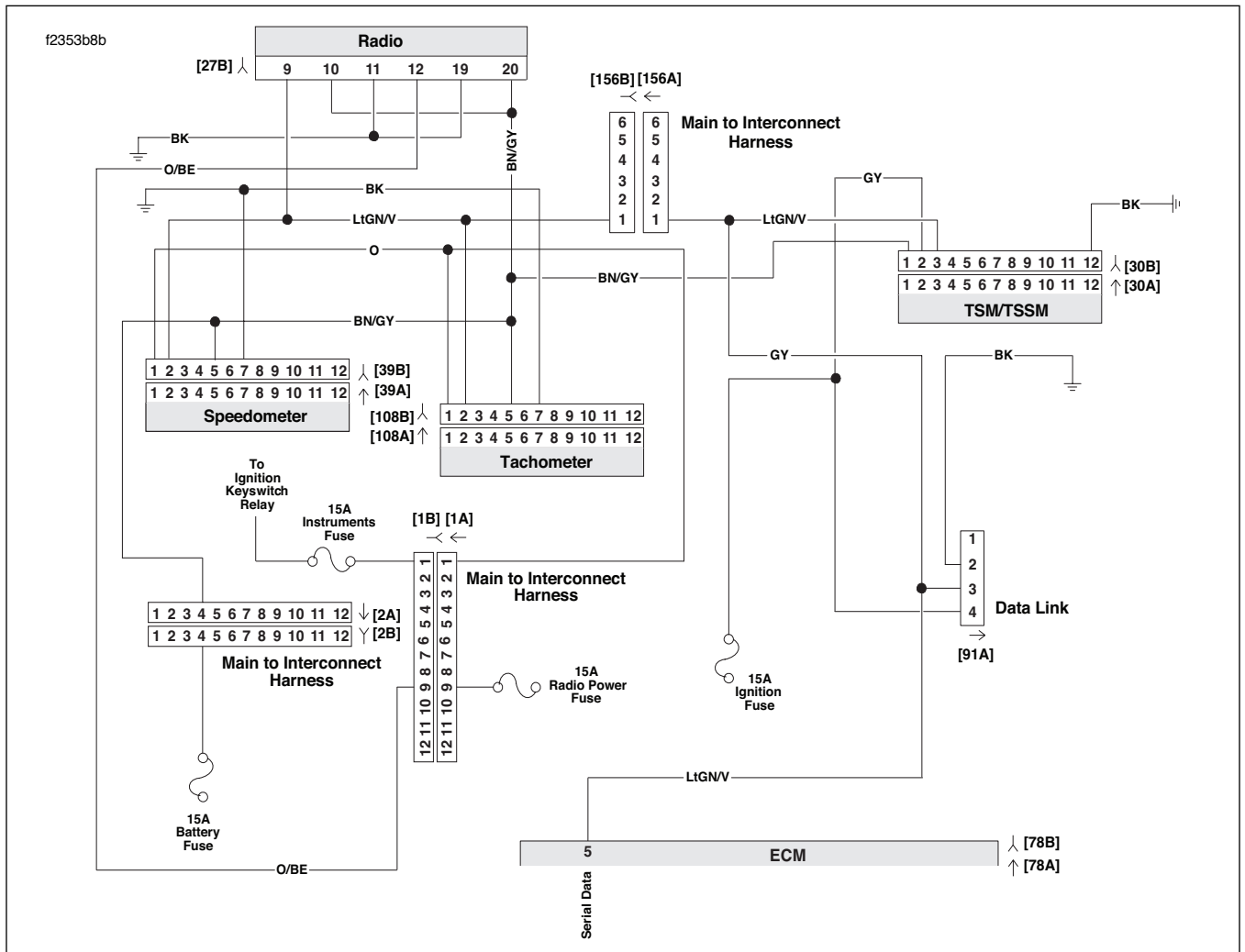

Figure 6-25. Serial Data Circuit: FLHX, FLHT/C/U, FLTR (Fuel Injected)

Table 6-28. Wire Harness Connectors

NO.	DESCRIPTION	MODEL	TYPE	LOCATION
[1]	Main to Interconnect Harness	FLHX, FLHTC/U	12-Place Deutsch (Black)	Inner Fairing - Right Radio Support Bracket
		FLTR	12-Place Deutsch (Black)	Inner Fairing - Below Radio (Right Side)
[2]	Main to Interconnect Harness	FLHX, FLHTC/U	12-Place Deutsch (Gray)	Inner Fairing - Right Fairing Support Brace
		FLTR	12-Place Deutsch (Gray)	Inner Fairing - Below Radio (Right Side)
[27]	Radio	All	23-Place Amp (Black)	Inner Fairing - Back of Radio (Right Side)
[30]	TSM/TSSM	All	12-Place Deutsch	Cavity in Crossmember at Rear of Battery Box (Under Seat)
[39]	Speedometer	FLHX, FLHTC/U	12-Place Packard	Inner Fairing (Back of Speedometer)
		FLTR	12-Place Packard	Under Bezel (Back of Speedometer)
[91]	Data Link	All	4-Place Deutsch	Under Right Side Cover
[78]	ECM	All	36-Place Packard	Under Right Side Cover
[108]	Tachometer	FLHX, FLHTC/U	12-Place Packard	Inner Fairing (Back of Tachometer)
		FLTR	12-Place Packard	Under Bezel (Back of Tachometer)
[156]	Main to Interconnect Harness	FLHX, FLHTC/U	6-Place Deutsch	Inner Fairing - Right Fairing Support Brace
		FLTR	6-Place Deutsch	Inner Fairing - Below Radio (Right Side)

Test 6.4b

STARTS, THEN STALLS: DTC U1300, U1301

NOTE
See *Diagnostic Notes* on Page 6-42.

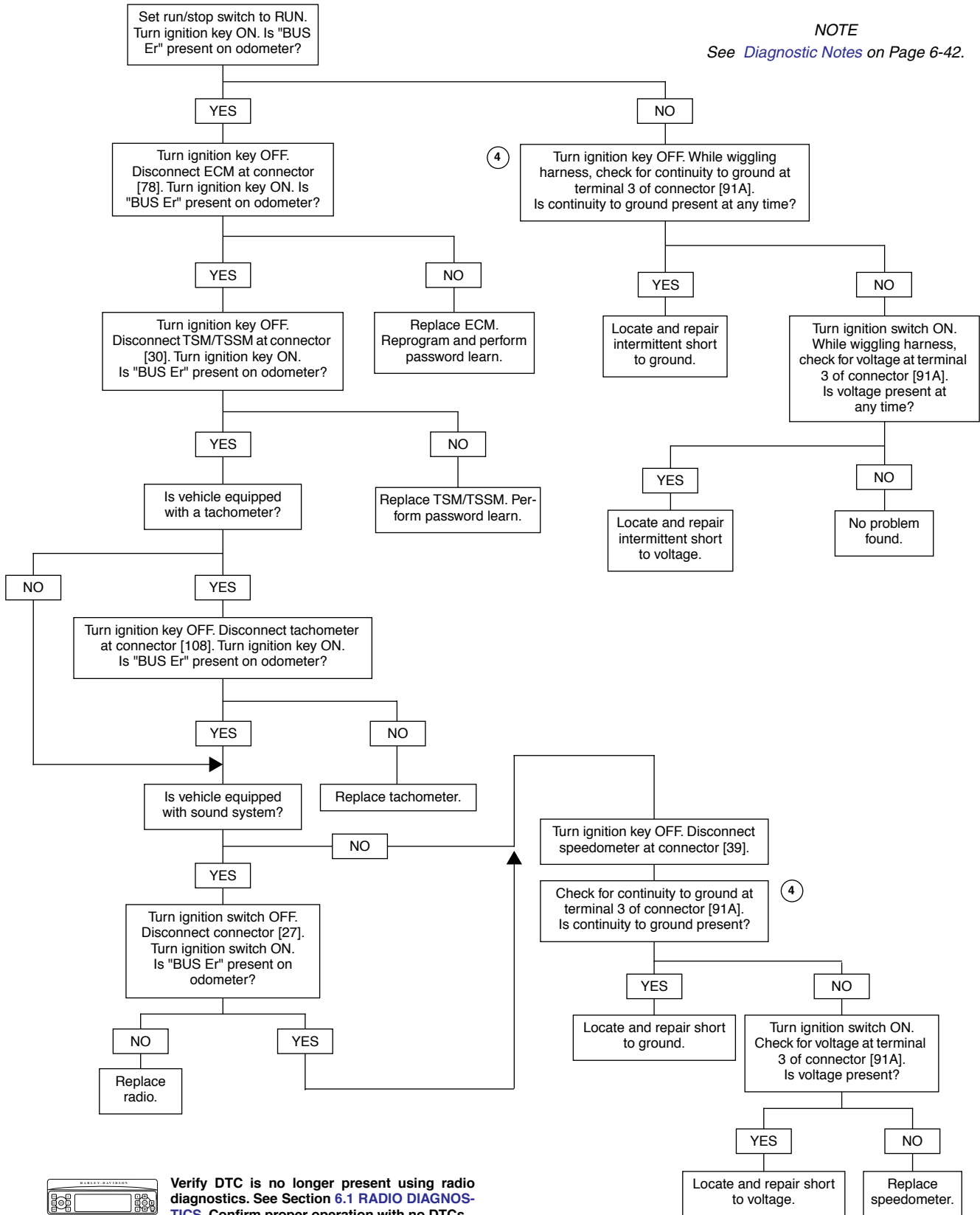

Verify DTC is no longer present using radio diagnostics. See Section 6.1 RADIO DIAGNOSTICS. Confirm proper operation with no DTCs.

Test 6.4c (Part 1 of 3)

INFOTAINMENT BUS SHORTED LOW/HIGH: DTC U1302

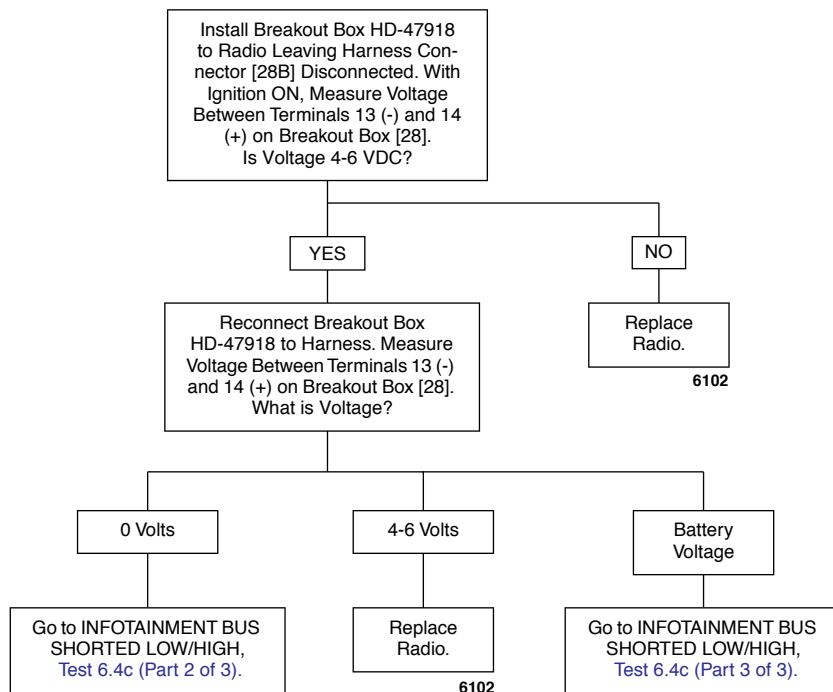

Verify DTC is no longer present using radio diagnostics. See Section 6.1 RADIO DIAGNOSTICS. Confirm proper operation with no DTCs.

Table 6-29. Wire Harness Connectors

NO.	DESCRIPTION	TYPE	LOCATION
[6]	Audio to Interconnect Harness	6-Place Deutsch (Black)	Inner Fairing - Top of Radio (Left Side)
[28]	Radio	35-Place Amp	Inner Fairing - Back of Radio (Left Side)
[149]	High Output Amplifier	23-Place Amp	Under Luggage Rack (Right Side)
[175]	Future	-	-
[184]	CB Module	12-Place Mini-Deutsch	Inner Fairing - Top of Radio (Left Side)
[185]	XM Module	12-Place Mini-Deutsch	Inner Fairing - Top of Radio (Left Side)
[186]	Future	-	-
[187]	Hands Free Phone Module	12-Place Mini-Deutsch	Inner Fairing - Top of Radio (Left Side)
[194]	Hands Free Phone Module	54-Place Amp	Inside Tour-Pak (Left Side)

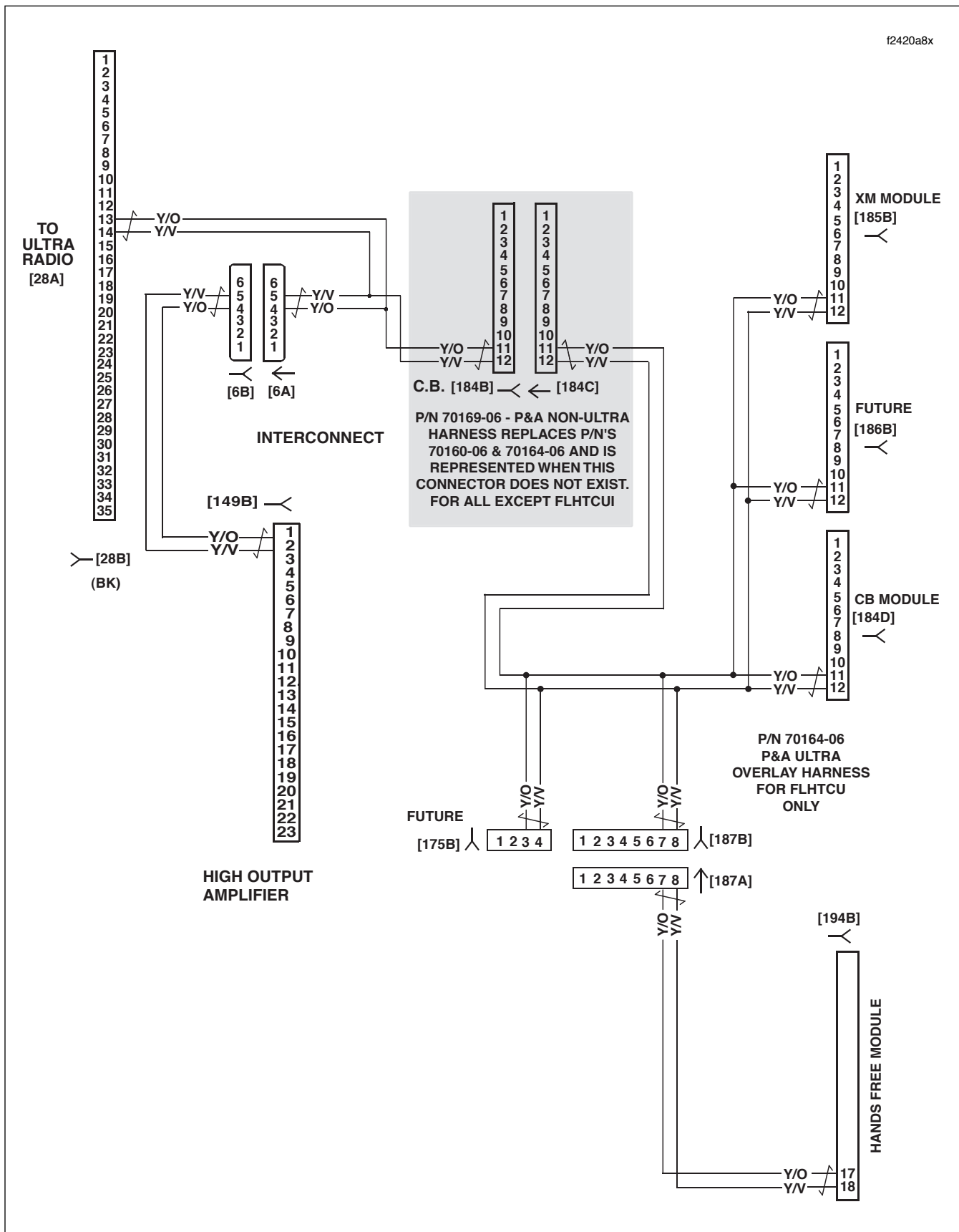
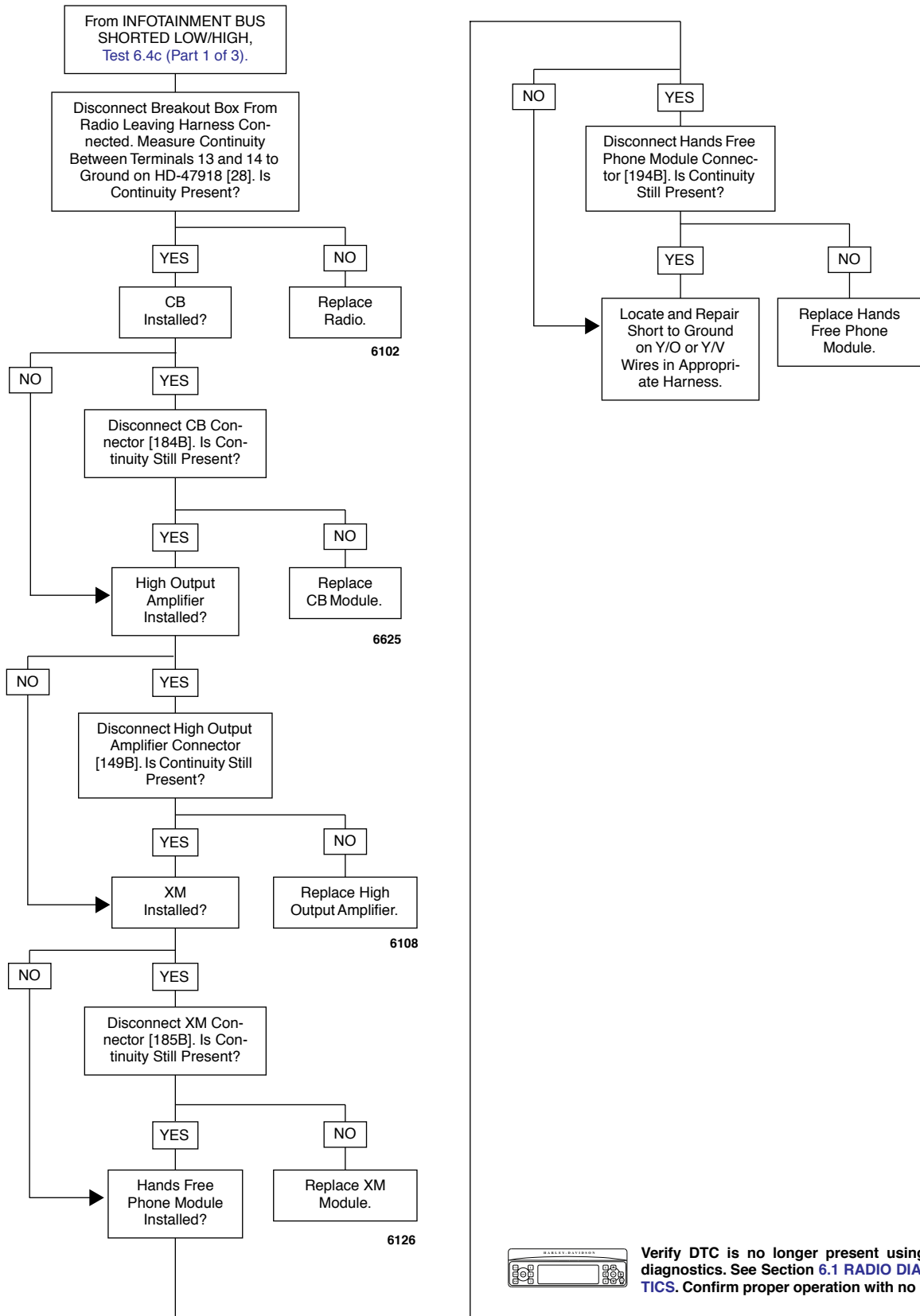

Figure 6-26. Infotainment BUS Circuit

Test 6.4c (Part 2 of 3)

INFOTAINMENT BUS SHORTED LOW/HIGH: DTC U1302



Verify DTC is no longer present using radio diagnostics. See Section 6.1 RADIO DIAGNOSTICS. Confirm proper operation with no DTCs.

Test 6.4c (Part 3 of 3)

INFOTAINMENT BUS SHORTED LOW/HIGH: DTC U1302

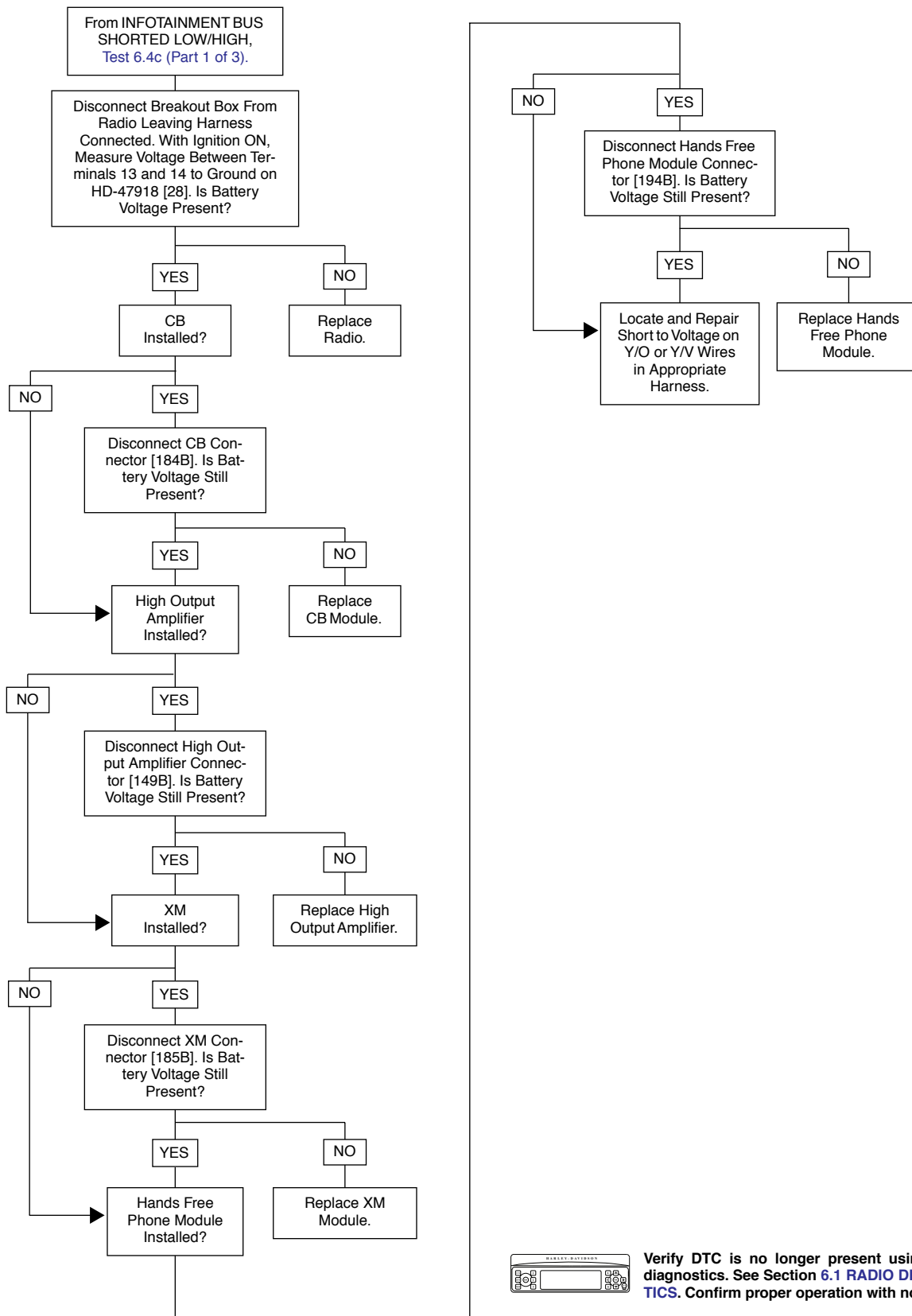

Verify DTC is no longer present using radio diagnostics. See Section 6.1 RADIO DIAGNOSTICS. Confirm proper operation with no DTCs.

Test 6.4d

INFOTAINMENT BUS LOST COMMUNICATIONS WITH HANDS FREE PHONE MODULE: DTC U1306

NOTE

See *Diagnostic Notes* on Page 6-42.

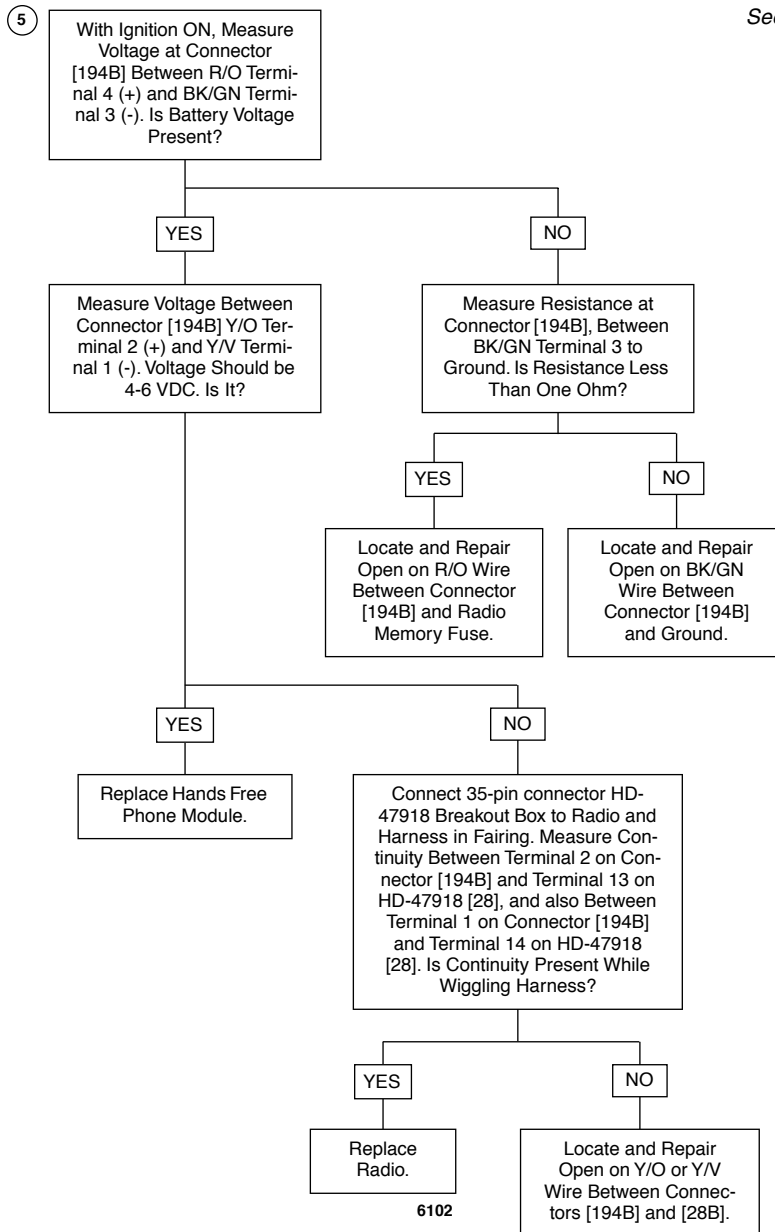

6102



Verify DTC is no longer present using radio diagnostics. See Section 6.1 RADIO DIAGNOSTICS. Confirm proper operation with no DTCs.

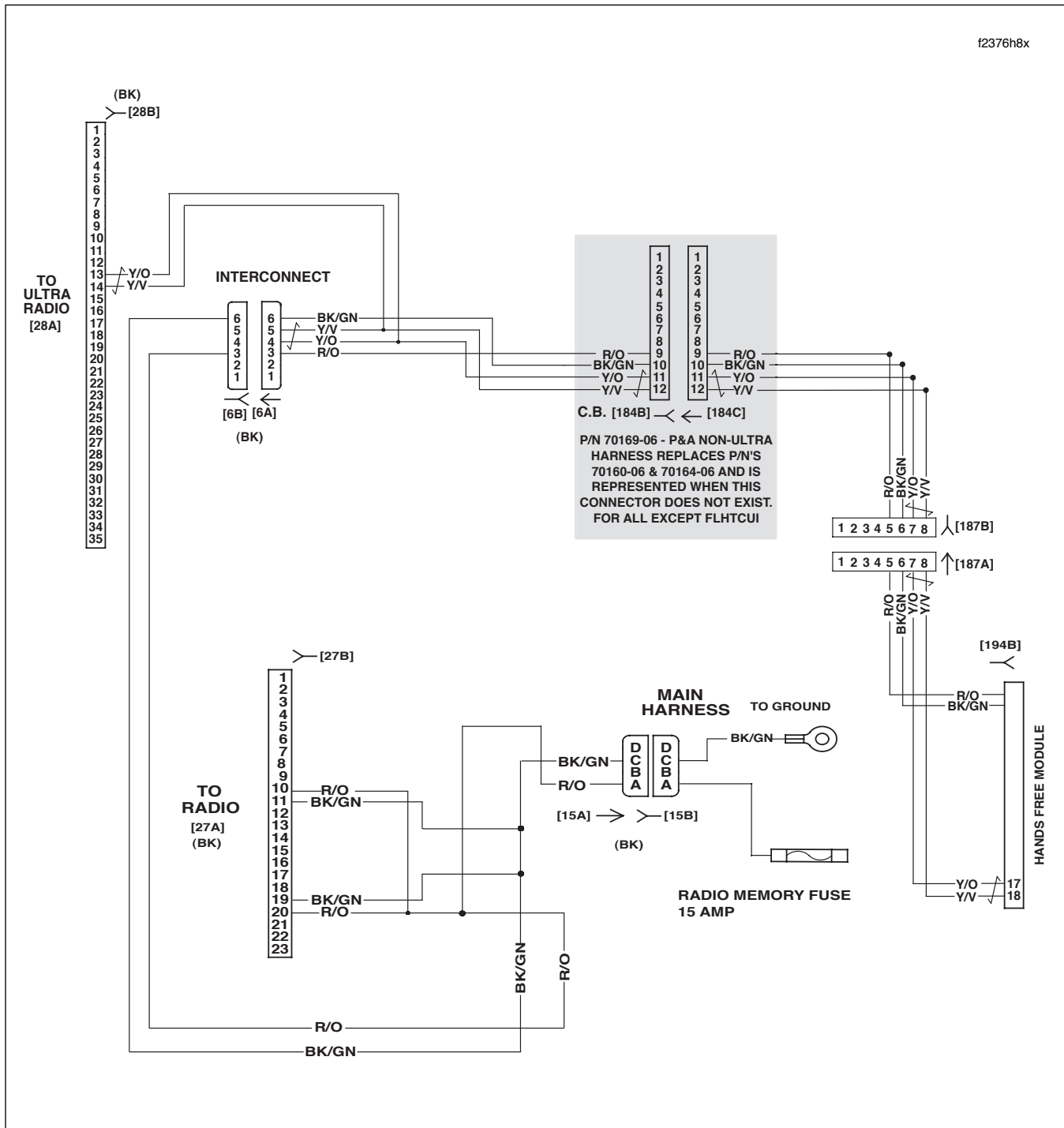

Figure 6-27. Hands Free Phone Circuit

Table 6-30. Wire Harness Connectors

NO.	DESCRIPTION	TYPE	LOCATION
[6]	Audio to Interconnect Harness	6-Place Deutsch (Black)	Inner Fairing - Top of Radio (Left Side)
[15]	Main to Interconnect Harness	4-Place Packard	Inner Fairing - Right Fairing Bracket
[27]	Radio	23-Place Amp	Inner Fairing - Back of Radio (Right Side)
[28]	Radio	35-Place Amp	Inner Fairing - Back of Radio (Left Side)
[184]	CB Module	12-Place Mini-Deutsch	Inner Fairing - Top of Radio (Left Side)
[187]	Hands Free Phone Module	12-Place Mini-Deutsch	Inner Fairing - Top of Radio (Left Side)
[194]	Hands Free Phone Module	54-Place Amp	Inside Tour-Pak (Left Side)

Test 6.4e

INFOTAINMENT BUS LOST COMMUNICATIONS WITH CB MODULE: DTC U1307

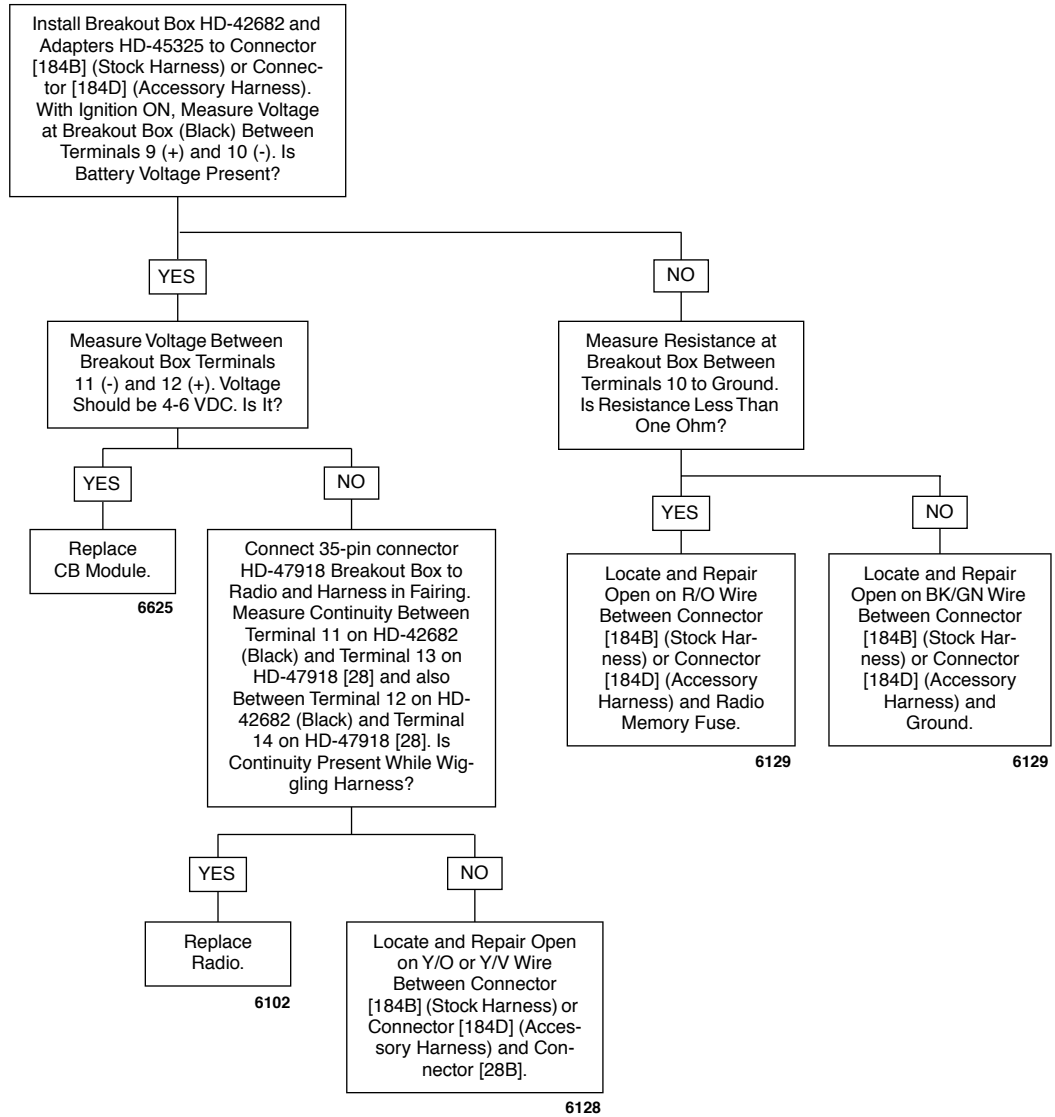

Verify DTC is no longer present using radio diagnostics. See Section 6.1 RADIO DIAGNOSTICS. Confirm proper operation with no DTCs.

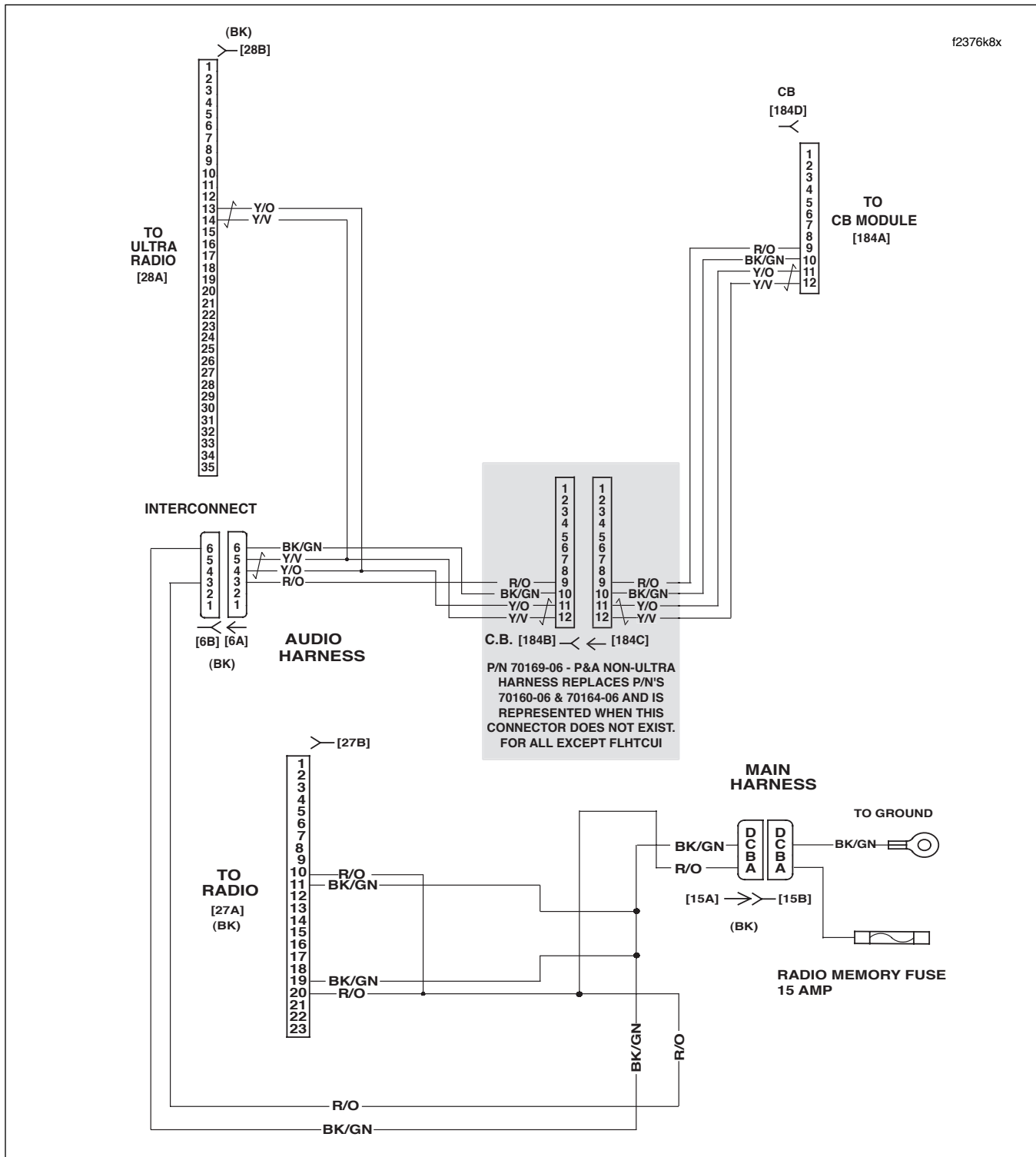

Figure 6-28. CB Circuit

Table 6-31. Wire Harness Connectors

NO.	DESCRIPTION	TYPE	LOCATION
[6]	Audio to Interconnect Harness	6-Place Deutsch (Black)	Inner Fairing - Top of Radio (Left Side)
[15]	Main to Interconnect Harness	4-Place Packard	Inner Fairing - Right Fairing Bracket
[27]	Radio	23-Place Amp	Inner Fairing - Back of Radio (Right Side)
[28]	Radio	35-Place Amp	Inner Fairing - Back of Radio (Left Side)
[184]	CB Module	12-Place Mini-Deutsch	Inner Fairing - Top of Radio (Left Side)

Test 6.4f

INFOTAINMENT BUS LOST COMMUNICATIONS WITH XM MODULE: DTC U1313

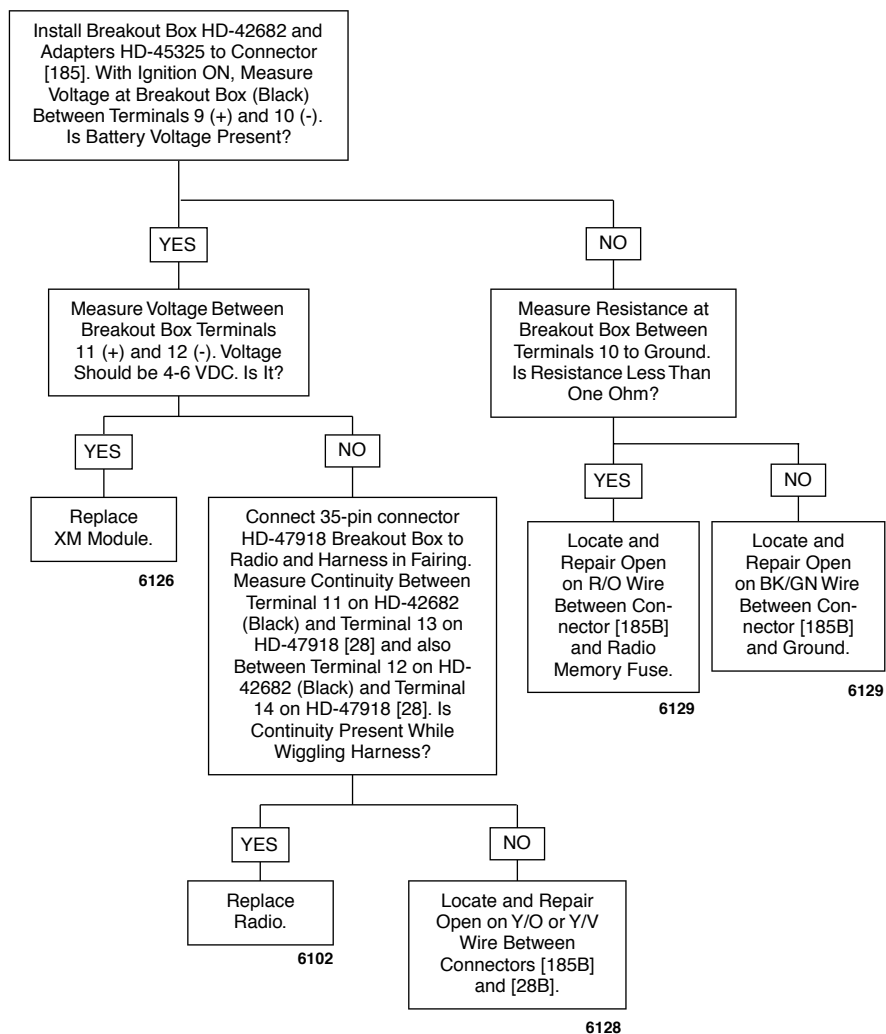

Verify DTC is no longer present using radio diagnostics. See Section 6.1 RADIO DIAGNOSTICS. Confirm proper operation with no DTCs.

Table 6-32. Wire Harness Connectors

NO.	DESCRIPTION	TYPE	LOCATION
[6]	Audio to Interconnect Harness	6-Place Deutsch (Black)	Inner Fairing - Top of Radio (Left Side)
[15]	Main to Interconnect Harness	4-Place Packard	Inner Fairing - Right Fairing Bracket
[27]	Radio	23-Place Amp	Inner Fairing - Back of Radio (Right Side)
[28]	Radio	35-Place Amp	Inner Fairing - Back of Radio (Left Side)
[185]	XM Module	12-Place Mini-Deutsch	Inner Fairing - Top of Radio (Left Side)

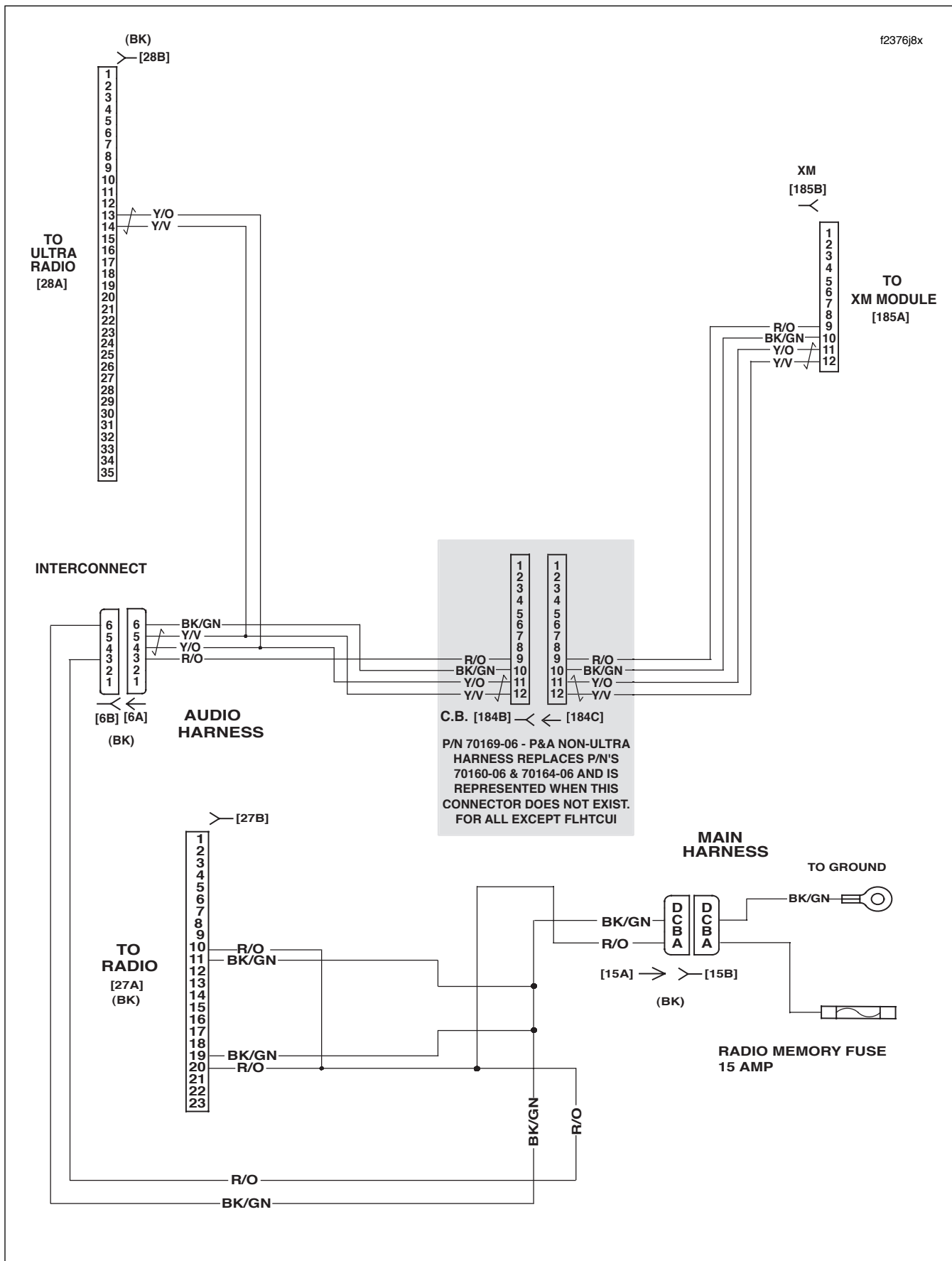
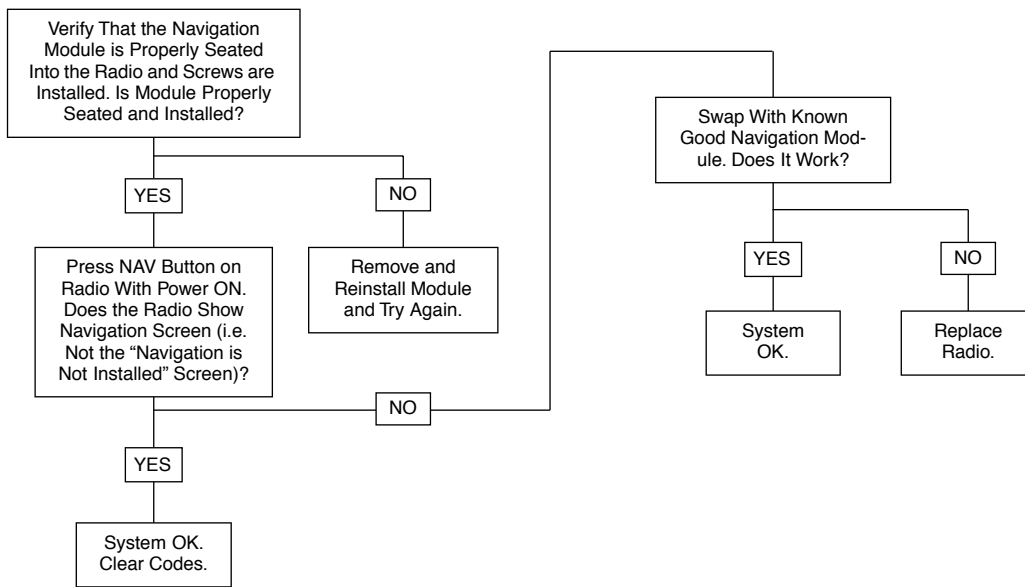

Figure 6-29. XM Circuit

Test 6.4g

INFOTAINMENT BUS LOST COMMUNICATIONS WITH NAVIGATION MODULE: DTC U1314



Verify DTC is no longer present using radio diagnostics. See Section 6.1 [RADIO DIAGNOSTICS](#). Confirm proper operation with no DTCs.

Test 6.4h

INFOTAINMENT BUS LOST COMMUNICATIONS WITH HIGH OUTPUT AMPLIFIER: DTC U1317

NOTE

See *Diagnostic Notes* on Page 6-42.

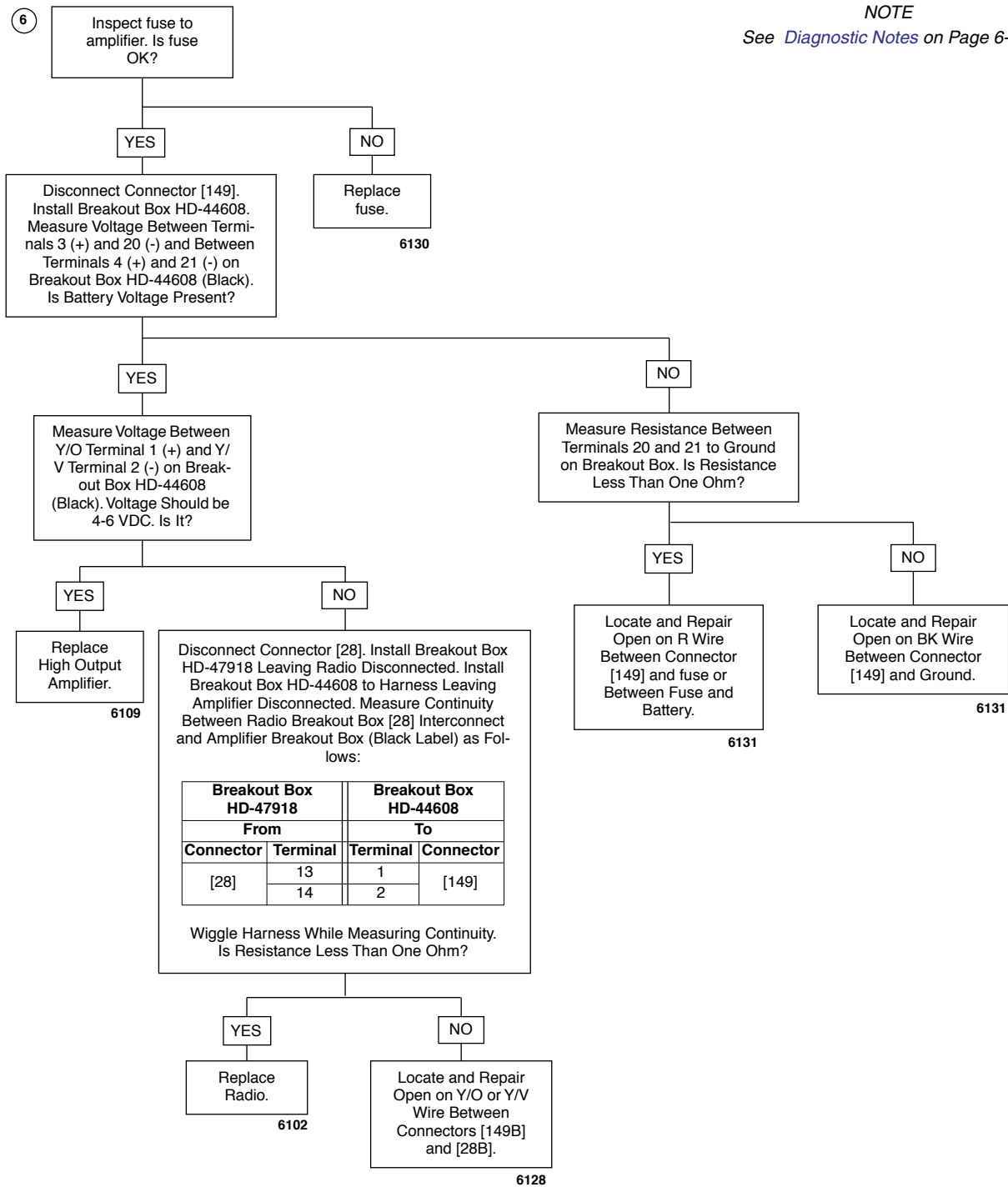

Verify DTC is no longer present using radio diagnostics. See Section 6.1 RADIO DIAGNOSTICS. Confirm proper operation with no DTCs.

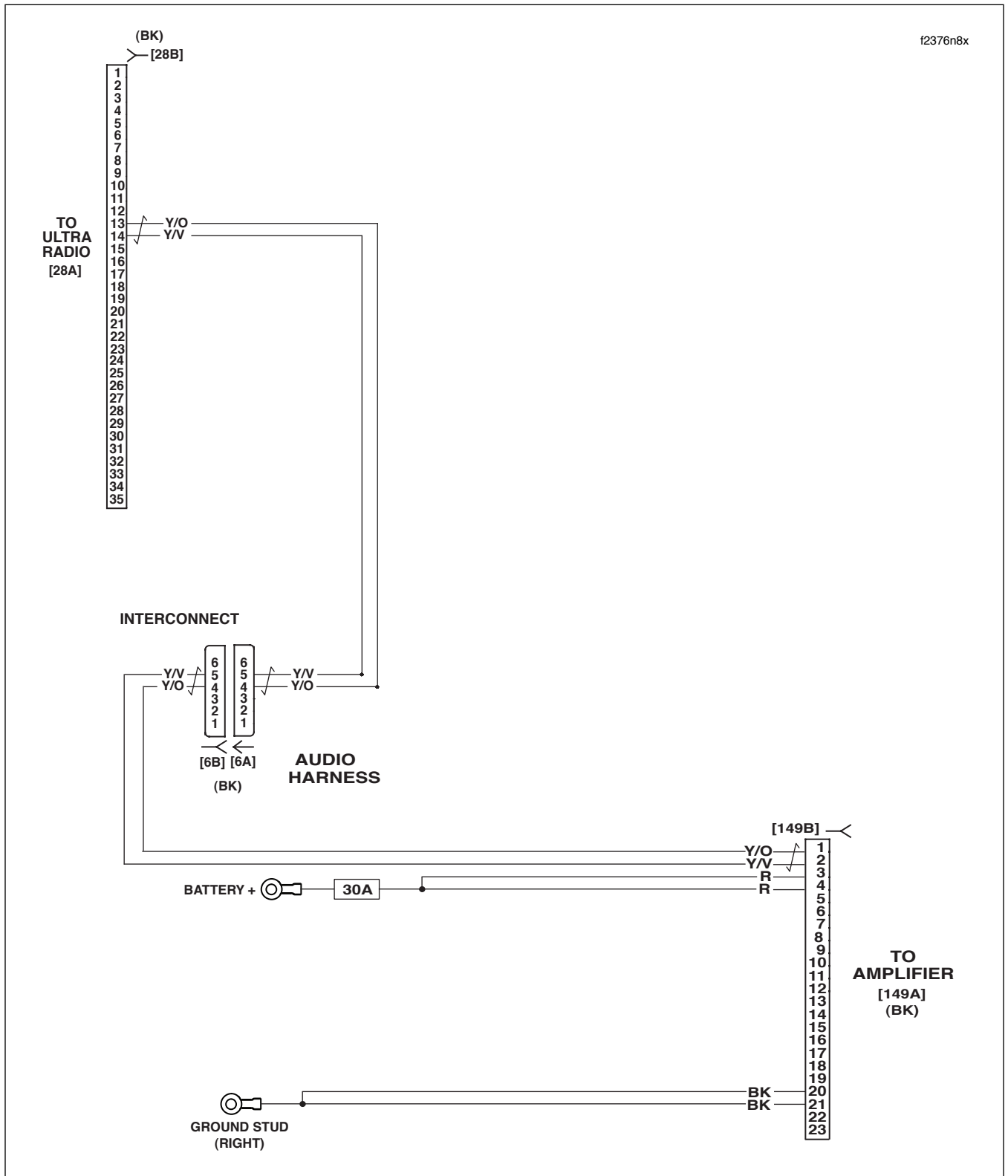

Figure 6-30. High Output Amplifier Circuit

Table 6-33. FLHTCU Wire Harness Connectors

NO.	DESCRIPTION	TYPE	LOCATION
[6]	Audio to Interconnect Harness	6-Place Deutsch (Black)	Inner Fairing - Top of Radio (Left Side)
[28]	Radio	35-Place Amp	Inner Fairing - Back of Radio (Left Side)
[149]	High Output Amplifier	23-Place Amp	Under Luggage Rack (Right Side)

GENERAL

A number of faults may occur that will not set a DTC. These faults are listed in [Table 6-34](#).

FACTORY DEFAULTS

If a symptom is present without a DTC, restoring ROM defaults back to the factory settings may resolve the issue, which can sometimes be caused by a unique sequence of rider interactions with the system.

Proceed as follows:

NOTE

On FLHTCU models, set Intercom, VOX and CB squelch to midpoint and turn Weather Alert to OFF.

- Turn the ignition ON with the radio OFF
- Push and hold softkeys 1 and 3 and OK for 2 seconds
- Push the arrow up 2 times
- Push softkey 2
- Turn off ignition for 20+ seconds
- Turn ignition on and verify all defaults have reset

The following are reset to the factory ROM defaults:

- Radio presets.
- volume levels, bass, treble, AVC, fader and VOX.
- Display contrast.
- External amplifier present is reset to no amplifier (if an external amplifier is present, it will take two LONG ignition cycles before the radio is set up to enable the external amplifier).

Table 6-34. Advanced Audio System Symptoms

NO.	SYMPTOM	TEST
1	Radio Inoperative	Go to Test 6.5a
2	Poor or No Reception	Go to Test 6.5b
3	Radio Beeps Every 30 Seconds	Go to Test 6.5c
4	CD in Radio Will Not Eject	Go to Test 6.5d
5	Static Present With Engine Running	Go to Test 6.5e
6	Auxiliary Input Audio Distorted	Go to Test 6.5f
7	CB Transmitter Inoperative and SWR Adjustment	Go to Test 6.5g (Part 1 of 4)
8	CB Receiver Inoperative	Go to Test 6.5h (Part 1 of 3)
9	Intercom Inoperative	Go to Test 6.5i
10	Handheld Microphone/PTT Inoperative	Go to Test 6.5j (Part 1 of 2)
11	Speaker Switch Malfunction	Go to Test 6.5k
12	Headset Speakers Inoperative	Go to Test 6.5l (Part 1 of 5)
13	No or Low Audio From Microphones	Go to Test 6.5m (Part 1 of 4)
14	No or Low Audio With High Output Amplifier	Go to Test 6.5n (Part 1 of 2)
15	No or Low Audio From XM or XM Inoperative	Go to Test 6.5o (Part 1 of 2)
16	XM - No or Intermittent Reception	Go to Test 6.5p
17	Navigation Inoperative	Go to Test 6.5q (Part 1 of 2)
18	AVC Inoperative	Go to Test 6.5r
19	Handlebar, Passenger or Sidecar Switches Inoperative	Go to Test 6.5s (Part 1 of 4)
20	CD Skipping	Go to Test 6.5t
21	Hands Free Phone Module Inoperative No or Low Audio <u>To</u> Hands Free Phone Module No or Low Audio <u>From</u> Hands Free Phone Module Hands Free Phone Module - Phone Not Pairing	Go to Test 6.5u (Part 1 of 5)

HOME

- CB or PHONE present is reset to no phone (this is used by the radio to enable the intercom setting if a CB or phone are present, and like the amplifier, it will take two LONG ignition cycles before the radio completely enables the intercom).
- All DTCs are reset.
- Navigation saved data. This data is immediately updated upon navigation startup, so the user should be unaffected.

DIAGNOSTICS

Diagnostic Notes

The reference numbers below correlate with the circled numbers on the [Test 6.5a](#) thru [Test 6.5u \(Part 5 of 5\)](#) flow charts.

1. If radio is uncalibrated, CB is not functional. The radio will beep periodically when it is not calibrated. If the CB is not allowed in a region (such as Japan, for example), then the unit will not operate.
2. Remove outer fairing. Disconnect antenna connector from CB and replace it with a dummy load, that is, the lamp included with tool HD-39448.

NOTE

The lamp acts as a load that allows the CB to be operated and provides a means of checking relative power output and modulation.

3. To use the load, screw the dummy load onto the antenna jack of the CB using the appropriate SWR METER ADAPTER (HD-48037). Depress the PTT switch. If the CB is transmitting a carrier wave, the lamp should illuminate. Speaking into the microphone should cause the lamp to flicker. It should get brighter and dimmer depending on how loud your voice is. A change in lamp brilliance means the CB is modulating.
4. Install RADIO BREAKOUT BOX (Part No. HD-47918).

5. Use HARNESS CONNECTOR TEST KIT (Part No. HD-41404A), black pin probes and patch cords.
6. Use HARNESS CONNECTOR TEST KIT (Part No. HD-41404A), black socket probes and patch cord.
7. Part No. 70172-06 CVO CB/XM Y-Harness used on stock FLHTCUSE.
8. Part No. 70164-06 Ultra Overlay Harness used on upgraded FLHTCUSE.
9. Part No. 70169-06 Non-Ultra Overlay Harness used on upgraded FLHX, FLHTC and FLTR.
10. Part No. 70160-06 Audio Harness used on FLHTCU and FLHTCUSE.
11. The amplifier fuse is an inline fuse for all accessory installations and is mounted in the fuse block for FLHTCUSE models.
12. It is possible to have a fault on more than one handlebar control as a result of the following configuration:
 - Terminal 5, V/BK wire is common to both the PTT/Squelch and Mode handlebar controls.
 - Terminal 8, BN/BK wire is common to both the PTT/Squelch and Audio handlebar controls.
 - Terminal 22, GY/GN wire is common to both the PTT/Squelch and Audio handlebar controls.
13. Terminal 3, PK/W wire is common to both the Mode and Audio handlebar controls. Therefore, it is possible to have a fault on more than one handlebar control as a result of this configuration.
14. Use HARNESS CONNECTOR TEST KIT (Part No. HD-41404A), brown pin probe and patch cord.
15. Some aftermarket exhaust systems may cause excessive pressure on the rear mounts causing the exhaust system to be put into a bind that creates excessive vibration that the CD player may not be able to isolate.
16. This 18-place connector is located on the hands free phone module. Disconnect the connector and GENTLY touch the probes to the terminals to make the measurement.
17. When prompt button is depressed, allow 10 seconds for voice prompt to respond.

Test 6.5a

RADIO INOPERATIVE: SYMPTOM 1

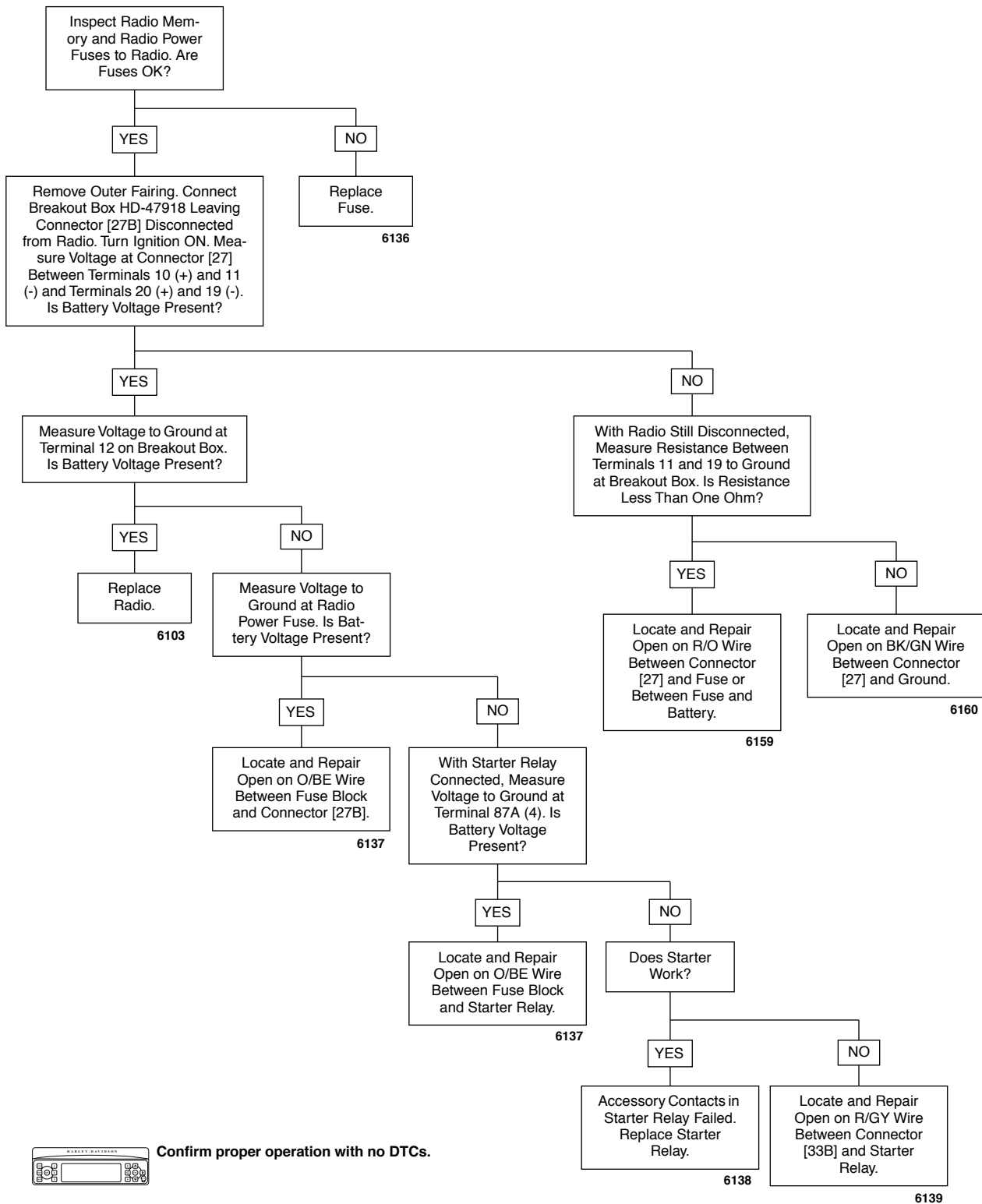

Confirm proper operation with no DTCs.

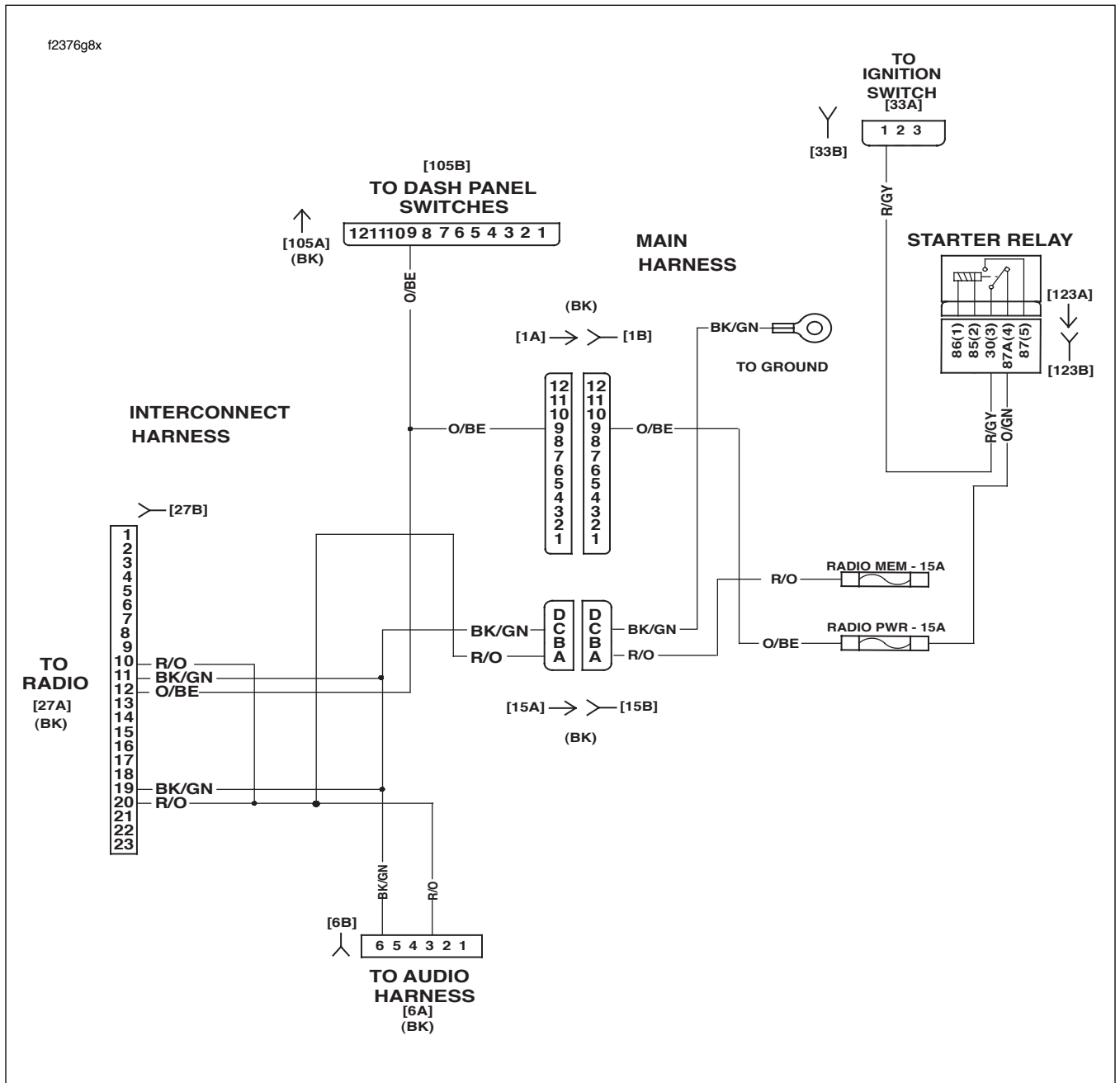

Figure 6-31. Radio Power

Table 6-35. FLHTCU Wire Harness Connectors

NO.	DESCRIPTION	TYPE	LOCATION
[1]	Main to Interconnect Harness	12-Place Deutsch	Inner Fairing - Right Radio Support Bracket
[6]	Audio to Interconnect Harness	6-Place Deutsch (Black)	Inner Fairing - Top of Radio (Left Side)
[15]	Main to Interconnect Harness	4-Place Packard	Inner Fairing - Right Fairing Bracket
[27]	Radio	23-Place Amp	Inner Fairing - Back of Radio (Right Side)
[33]	Ignition/Light Key Switch	3-Place Packard	Inner Fairing - Under Radio
[105]	Fairing Cap Switches	12-Place Multilock	Inner Fairing - Above Upper Fork Bracket (Right Side)
[123]	Starter Relay	Relay Connector	Rear of Battery Box (Under Seat) - Left Side

Test 6.5b

POOR OR NO RECEPTION: SYMPTOM 2

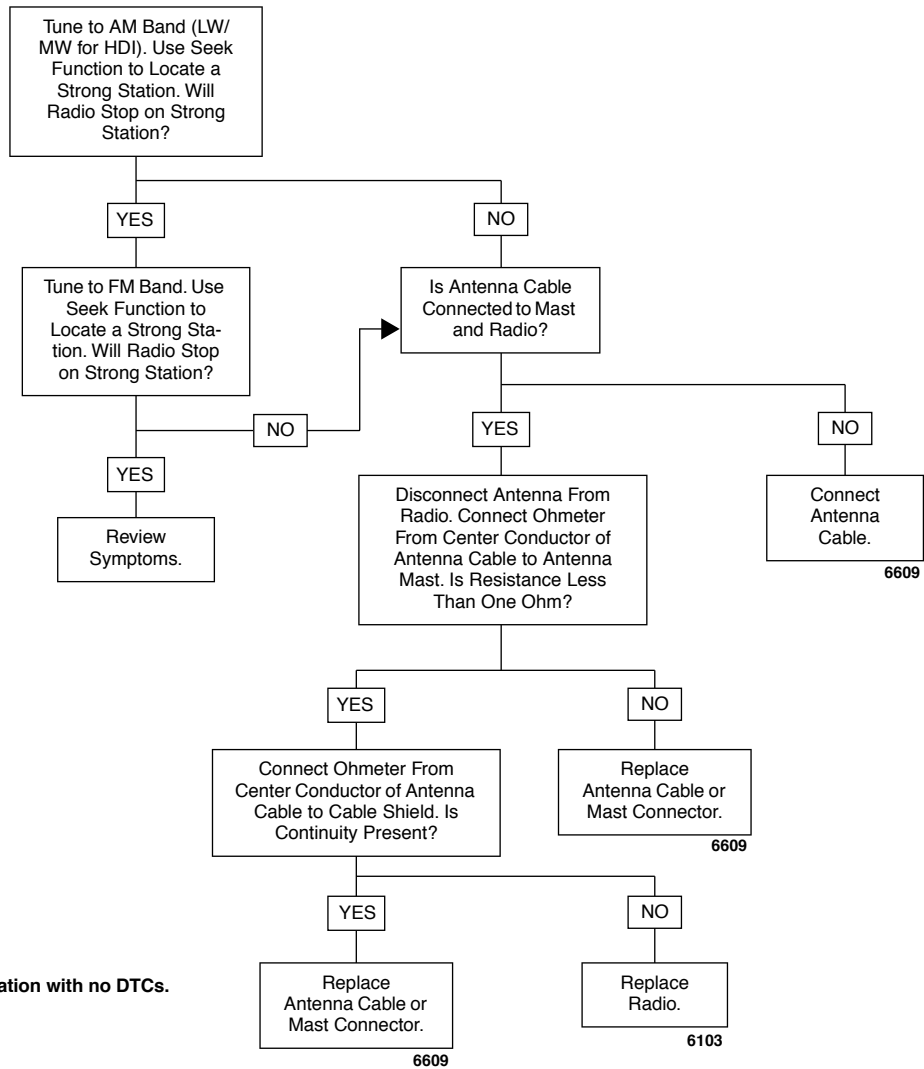

Confirm proper operation with no DTCs.

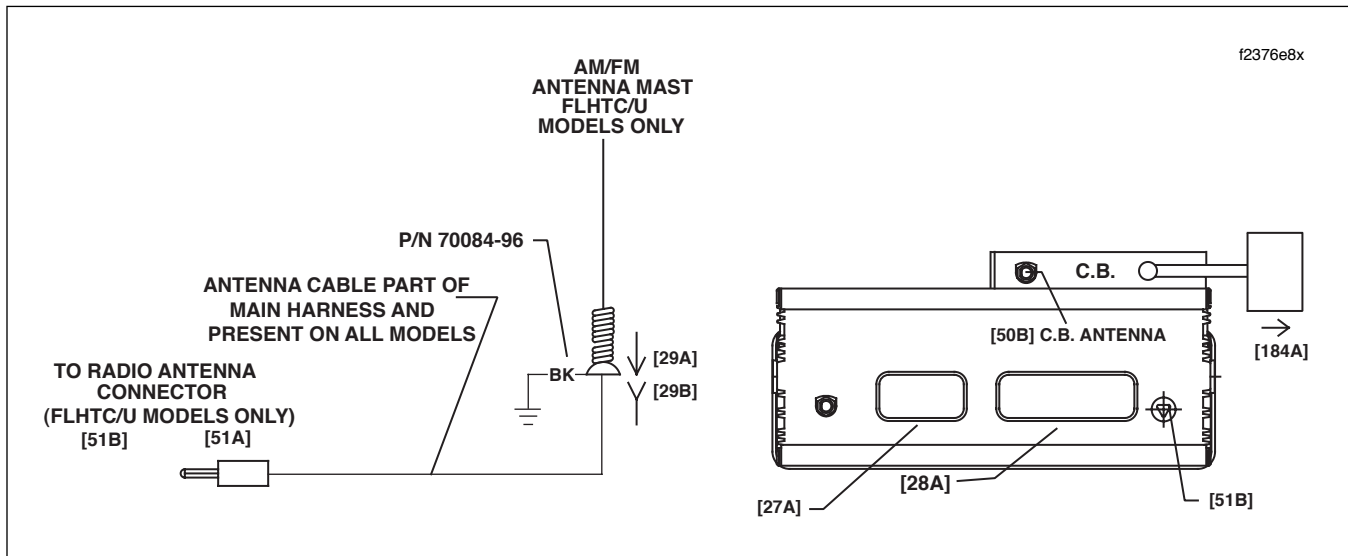

Figure 6-32. Radio Antenna Cable and Mast

Test 6.5c

RADIO BEEPS EVERY 30 SECONDS: SYMPTOM 3

Radio Uncalibrated.
Calibrate Radio.



Confirm proper operation with no DTCs.

Test 6.5d

CD IN RADIO WILL NOT EJECT: SYMPTOM 4

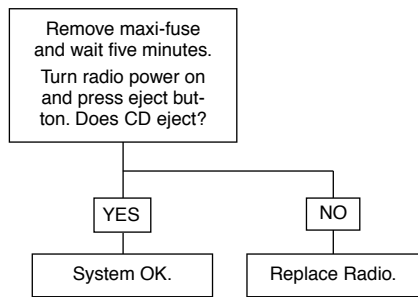

6103

NOTE

Any disassembly of radio voids warranty.



Confirm proper operation with no DTCs.

Test 6.5e

STATIC PRESENT WITH ENGINE RUNNING: SYMPTOM 5

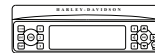
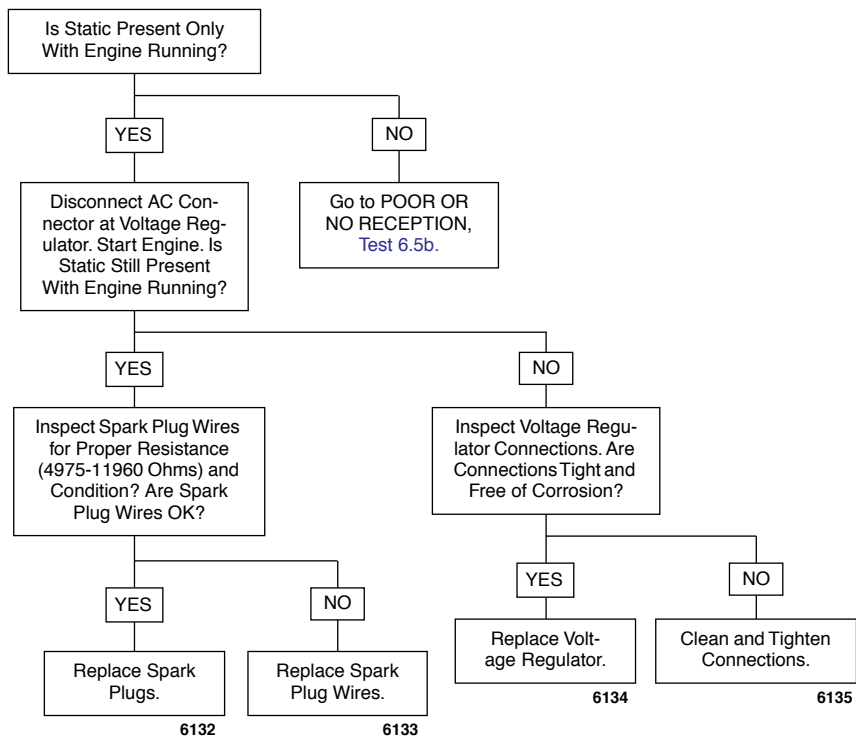

Confirm proper operation with no DTCs.

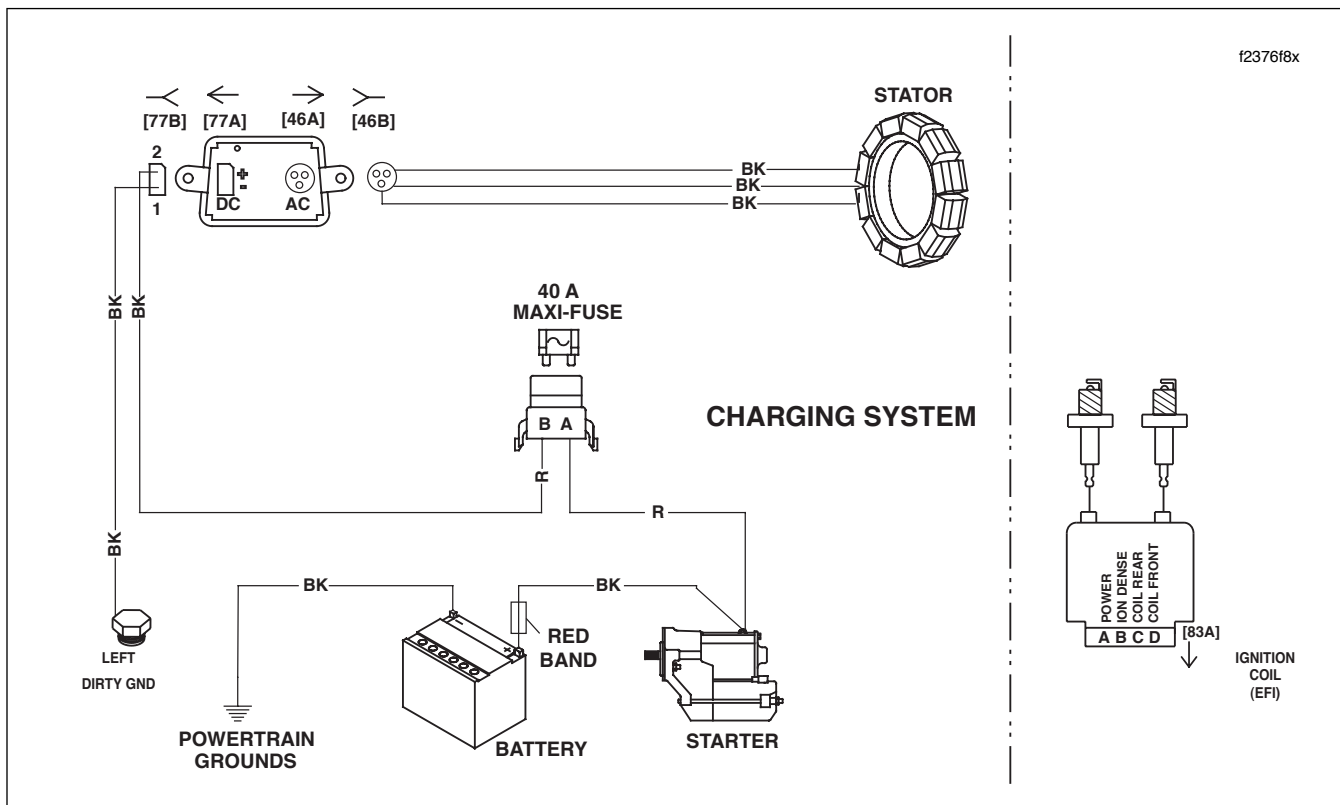

Figure 6-33. Voltage Regulator/Spark Plug Connections

Test 6.5f

AUXILIARY INPUT AUDIO DISTORTED: SYMPTOM 6

Turn Auxiliary Device
Volume Down.



Confirm proper operation with no DTCs.

Test 6.5g (Part 1 of 4)

CB TRANSMITTER INOPERATIVE: SYMPTOM 7

NOTE

See *Diagnostic Notes* on Page 6-61.

1

Perform setup as follows:

- Press POWER button to turn radio ON.
- Press INT button. Press Softkey 1 to turn Intercom OFF.
- Set fairing mounted Headset/Speaker Switch to SPEAKER.
- Press COM button. Press Softkey 1 to turn CB radio ON.
- Set Volume Control to Middle position on horizontal bar graph display.

NOTE

If CB does not power up or appear on radio display, see *INFOTAINMENT BUS LOST COMMUNICATIONS WITH CB MODULE: DTC U1307, Test 6.4e.*

Depressing Any PTT Switch Will Change the Radio Display to Reflect CB Mode and Cause the Transmitter to Transmit. With PTT Switch Depressed, Channel Number Will be Inverted. Are These Your Observations?

YES

System OK.

NO

Tune Known Good Receiver to Same Channel Number as Transmitter. Test Transmitter. Transmitter OK?

YES

Go to CB TRANSMITTER INOPERATIVE, [Test 6.5g \(Part 3 of 4\)](#), and Perform SWR Adjustment Procedures. Can SWR be Adjusted to 2:1 or Less?

YES

System OK.

NO

Go to CB TRANSMITTER INOPERATIVE, [Test 6.5g \(Part 4 of 4\)](#), and Perform CB Antenna Check.

NO

Does Unit Under Test Receiver Work OK?

YES

Does Display Change When PTT is Depressed?

YES

Go to CB TRANSMITTER INOPERATIVE, [Test 6.5g \(Part 2 of 4\)](#).

NO

Replace CB Module. **6625**

NO

Go to the Appropriate PTT Inoperative Chart.

DTC	DESCRIPTION	GO TO
B2009	Handlebar Switches Open	
	PTT/Squelch	Test 6.2d (Part 3 of 3)
B2012	Passenger Switches Open	
	Audio/PTT	Test 6.2g (Part 1 of 2)
B2015	Sidecar Switches Open	
	PTT/Mode	Test 6.2j

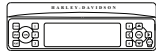

Confirm proper operation with no DTCs.

Test 6.5g (Part 2 of 4)

CB TRANSMITTER INOPERATIVE: SYMPTOM 7

NOTE
See *Diagnostic Notes* on Page 6-61.

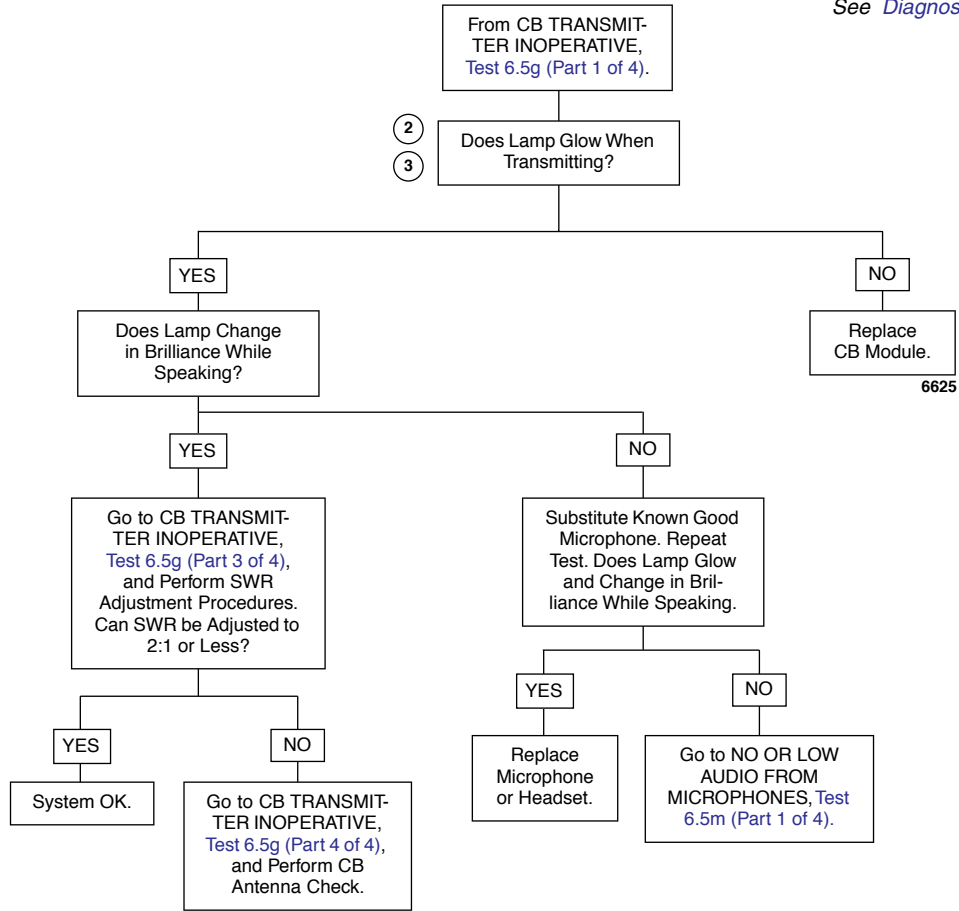

Confirm proper operation with no DTCs.

Test 6.5g (Part 3 of 4)

CB TRANSMITTER INOPERATIVE: SYMPTOM 7

SWR ADJUSTMENT

CAUTION

Do not press PTT switches with antenna and SWR meter disconnected. Transceiver damage could result.

Standing wave ratio (SWR) is a technical term for the procedure that checks how well the CB transmitter and antenna are matched. The SWR should be 2:1 or below on channel 20. A SWR of 1:1 is optimum.

To check SWR, a SWR meter or bridge is required. Your Harley-Davidson dealer will either have a SWR meter or direct you to a CB repair shop for a SWR check. Since the operating procedures for SWR meters vary, be sure you carefully follow the operating instructions for the SWR meter being used.

1. Locate motorcycle outdoors or in a building with a ceiling of 11 ft. (3.4 m) minimum above floor. Also, there must be 8 ft. (2.4 m) of radial clearance around motorcycle. Adjusting the SWR in an area with a lower ceiling and/or less radial clearance may result in an inaccurate adjustment.
2. Remove the outer fairing. Obtain Radio Shack SWR Meter (Part No. 21-534) or equivalent and SWR METER ADAPTERS (HD-48037). Remove the antenna cable and connect the SWR meter to the CB module. Connect the antenna cable to the SWR meter.
3. Check that the antenna loading coil bracket in Tour-Pak is tight and that antenna cable is tightly connected to loading coil.
4. Check that antenna mast is threaded securely on to base and set screw is tight.
5. Before measuring the SWR, the SWR meter must be calibrated. Follow the instructions for the meter being used. The following procedure is the general calibration most meter instructions specify.

CAUTION

Do not touch the antenna or meter during calibration or SWR measurement. Move CAL knob and then move your hand away from meter while calibrating.

6. With ignition and CB switches ON, the SWR meter set on "FWD", Channel 20 selected, press either PTT switches. Hold the PTT switch and rotate the calibration (CAL) control until the meter needle aligns with the "CAL" mark.
7. Release the PTT switch and move the FWD/REF switch to "REF" (reflected).

CAUTION

Do not touch the antenna or meter during calibration or SWR measurement. Move CAL knob and then move your hand away from meter while calibrating. Do not press PTT switches with antenna and SWR meter disconnected. Transceiver damage could result.

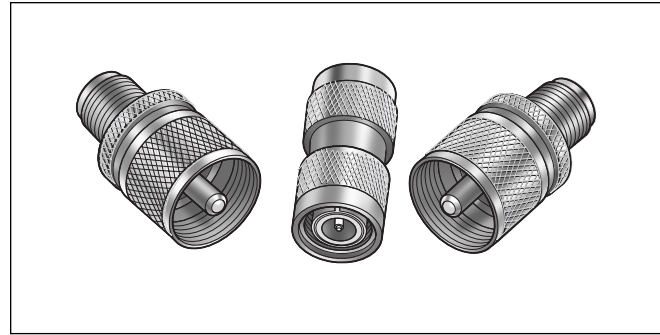

Figure 6-34. SWR Meter Adapters (Part No. HD-48037)

8. Press and hold either PTT switch. The meter reading is the SWR.
9. If SWR is more than 3:1, remove antenna cable from CB module. Using clip-on test leads, connect one lead of ohmmeter to center pin in antenna lead and other lead to antenna mast. Meter must read 1 ohm or less. Wiggle or flex mast while observing meter. If resistance is more than 1 ohm or varies when mast is wiggled, replace mast. Inspect connections at base of loading coil and at mounting bracket. If the SWR is less than 3:1, loosen antenna set screw and change mast length.

NOTE

It is normal to observe a reading of less than one ohm between the center conductor and ground due to the configuration of the loading coil.

10. Repeat Step 8. If SWR became higher, adjust antenna mast in opposite direction. Continue adjusting antenna until the minimum SWR is achieved. If you cannot obtain an SWR of 2:1 or less by adjusting the antenna length, make the mast shorter to improve the SWR. Remove mast and use grinder to shorten mast (grind in small increments). If SWR cannot be adjusted to less than 2:1, see CB TRANSMITTER INOPERATIVE, [Test 6.5g \(Part 4 of 4\)](#).
11. After SWR is adjusted on channel 20, check SWR on channels 1 and 40. Adjust the mast length to obtain a balance between channels 1 and 40.

NOTE

Check the SWR if a luggage rack is installed on the Tour-Pak cover. Be sure that the Tour-Pak cover is closed when the check is performed. Accessories mounted on the Tour Pak may affect the SWR reading and broadcast range, so the luggage rack should be mounted as far forward as possible. The Ultra Tour-Pak chrome accent rail also can adversely affect SWR.

Test 6.5g (Part 4 of 4)

CB TRANSMITTER INOPERATIVE: SYMPTOM 7

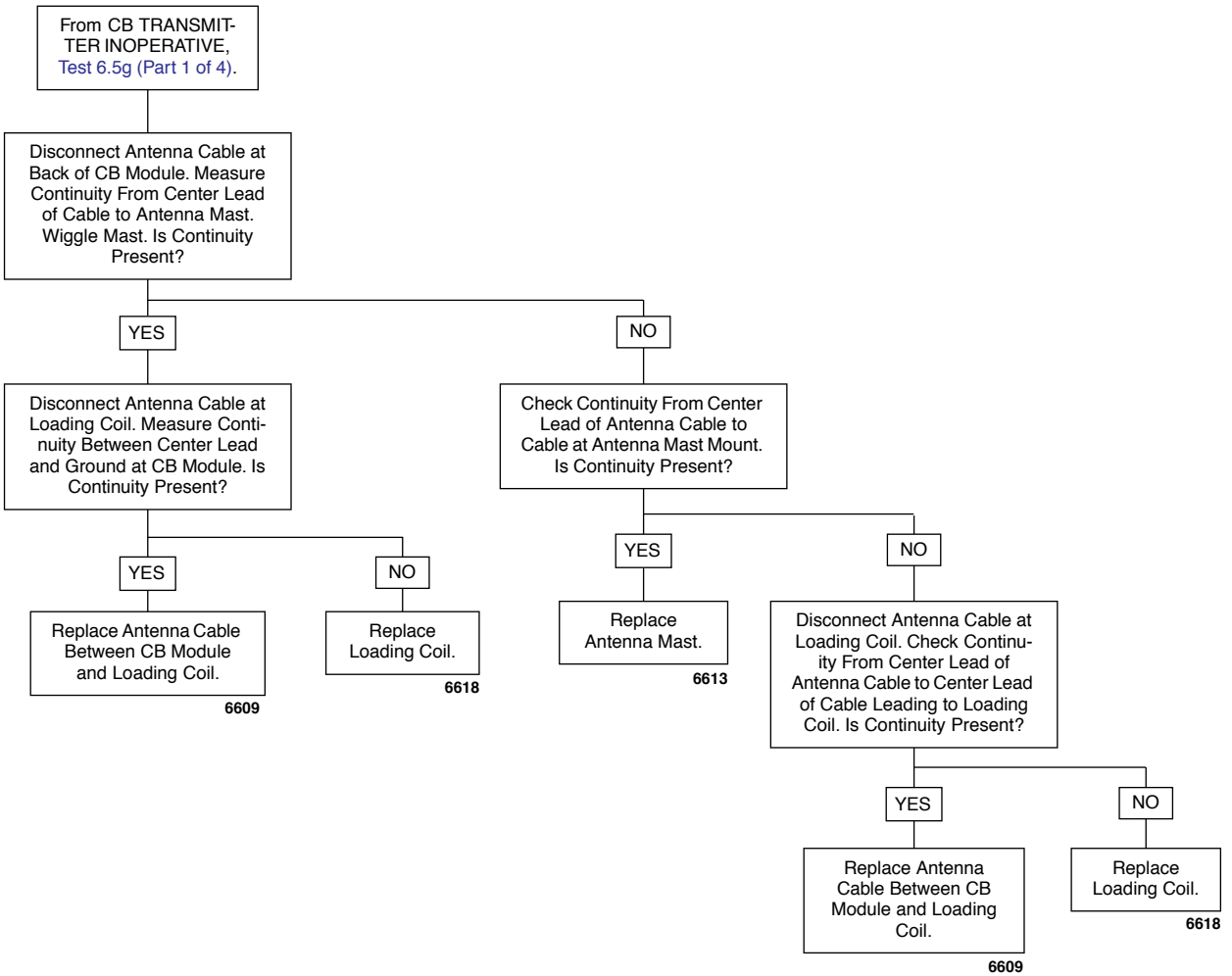

Confirm proper operation with no DTCs.

Test 6.5h (Part 1 of 3)

CB RECEIVER INOPERATIVE: SYMPTOM 8

NOTE

See *Diagnostic Notes* on Page 6-61.

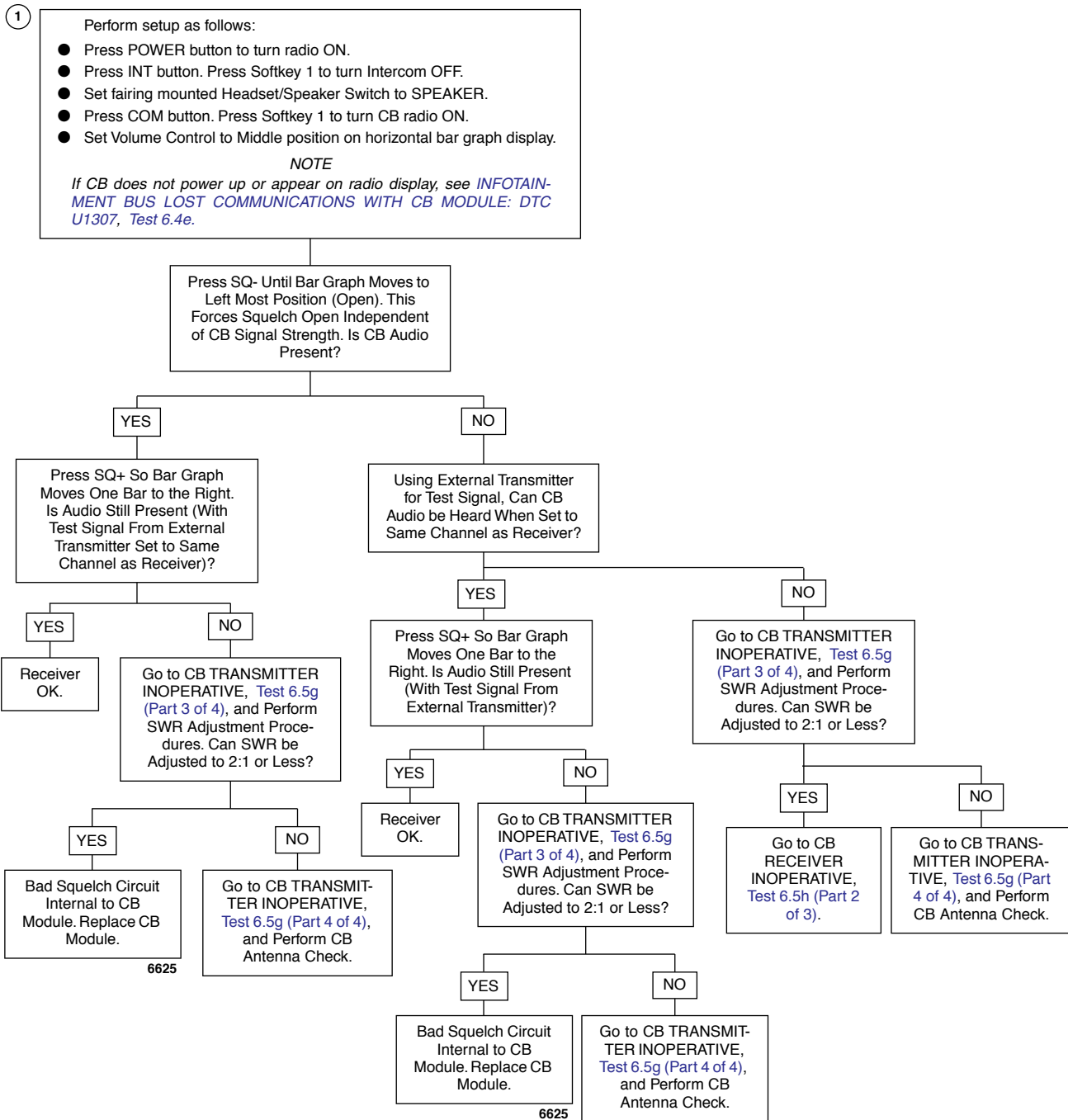

Confirm proper operation with no DTCs.

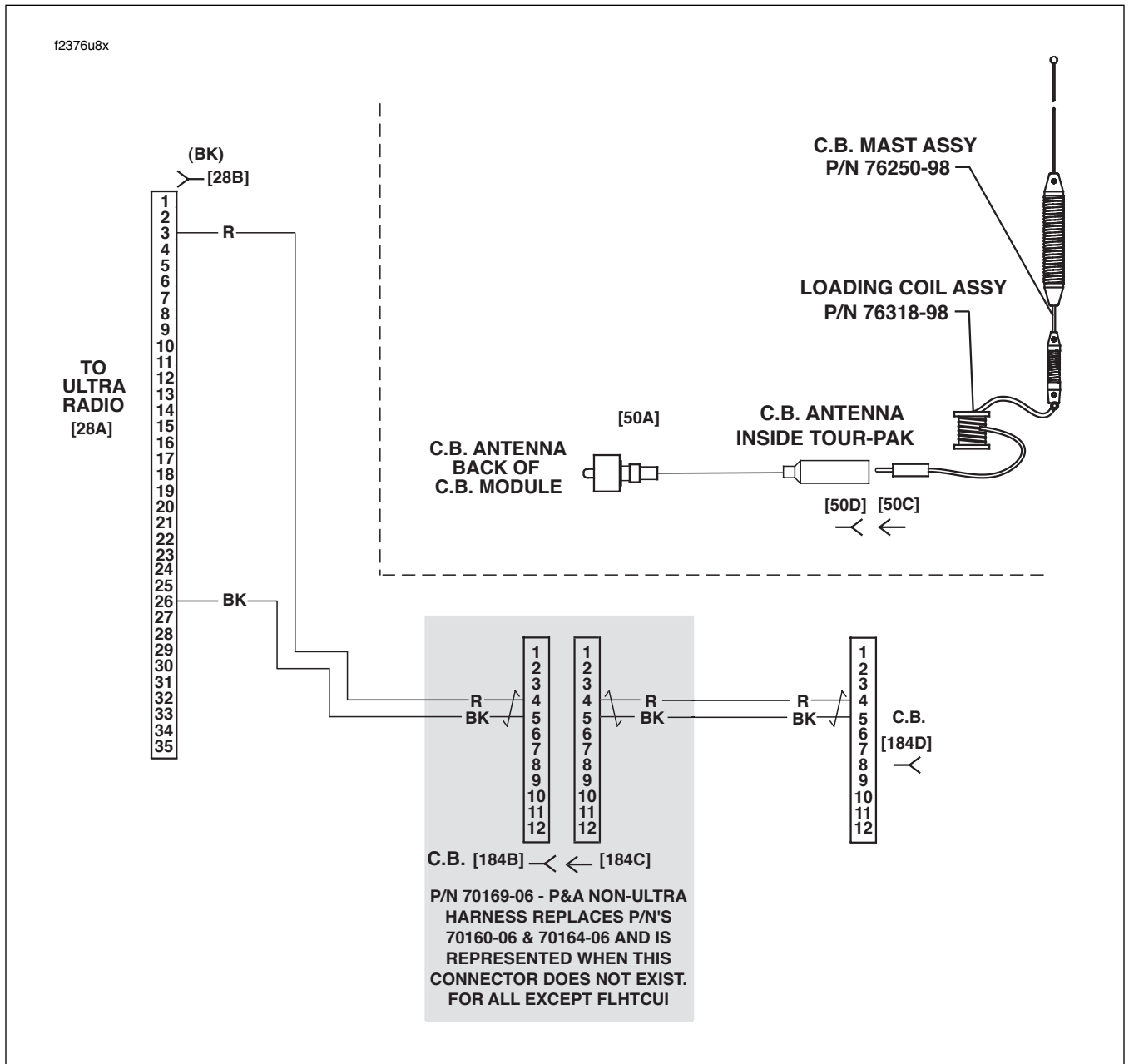

Figure 6-35. CB Receiver Audio Circuit

Table 6-36. FLHTCU Wire Harness Connectors

NO.	DESCRIPTION	TYPE	LOCATION
[28]	Radio	35-Place Amp	Inner Fairing - Back of Radio (Left Side)
[50]	CB Antenna Cable	-	Inner Fairing - Back of CB Module
[184]	CB Module	12-Place Mini-Deutsch	Inner Fairing - Top of Radio (Left Side)

Test 6.5h (Part 2 of 3)

CB RECEIVER INOPERATIVE: SYMPTOM 8

NOTE

See *Diagnostic Notes* on Page 6-61.

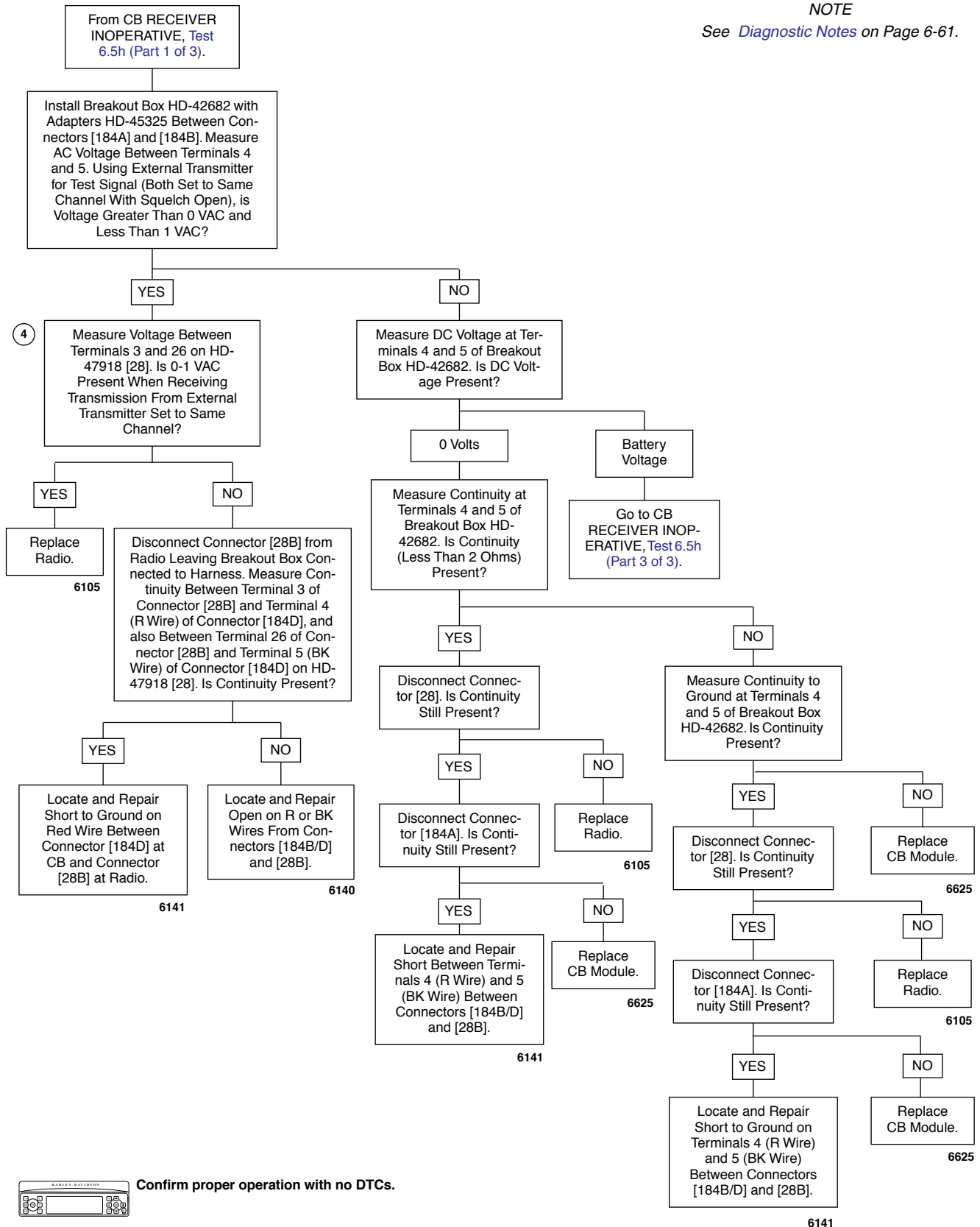

Confirm proper operation with no DTCs.

Test 6.5h (Part 3 of 3)

CB RECEIVER INOPERATIVE: SYMPTOM 8

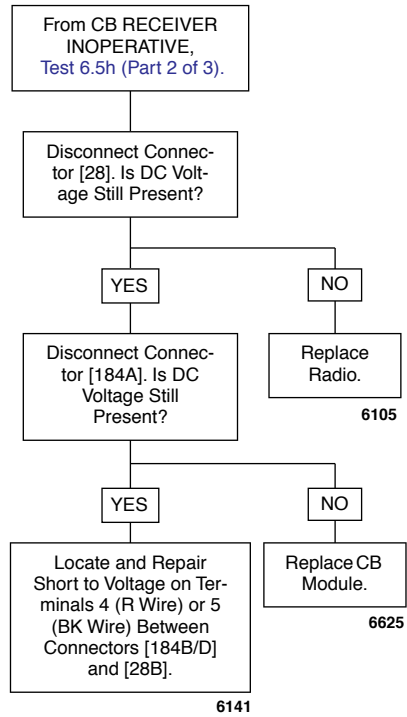

Confirm proper operation with no DTCs.

Test 6.5i

INTERCOM INOPERATIVE: SYMPTOM 9

Perform setup as follows:

- Press POWER button to turn radio ON.
- Set fairing mounted Headset/Speaker Switch to HEADSET.
- Press COM button. Press Softkey 1 to turn CB radio OFF.
- Press INT button. Press Softkey 1 to turn Intercom ON (Setup Mode).

NOTE

If intercom will not enter setup mode, then intercom is not installed. See Dealer for assistance.

- Press Softkey 4 to adjust VOX sensitivity to greater than “10” bars.
- Set Front and Rear Intercom Volume Control to Middle position on horizontal bar graph display.

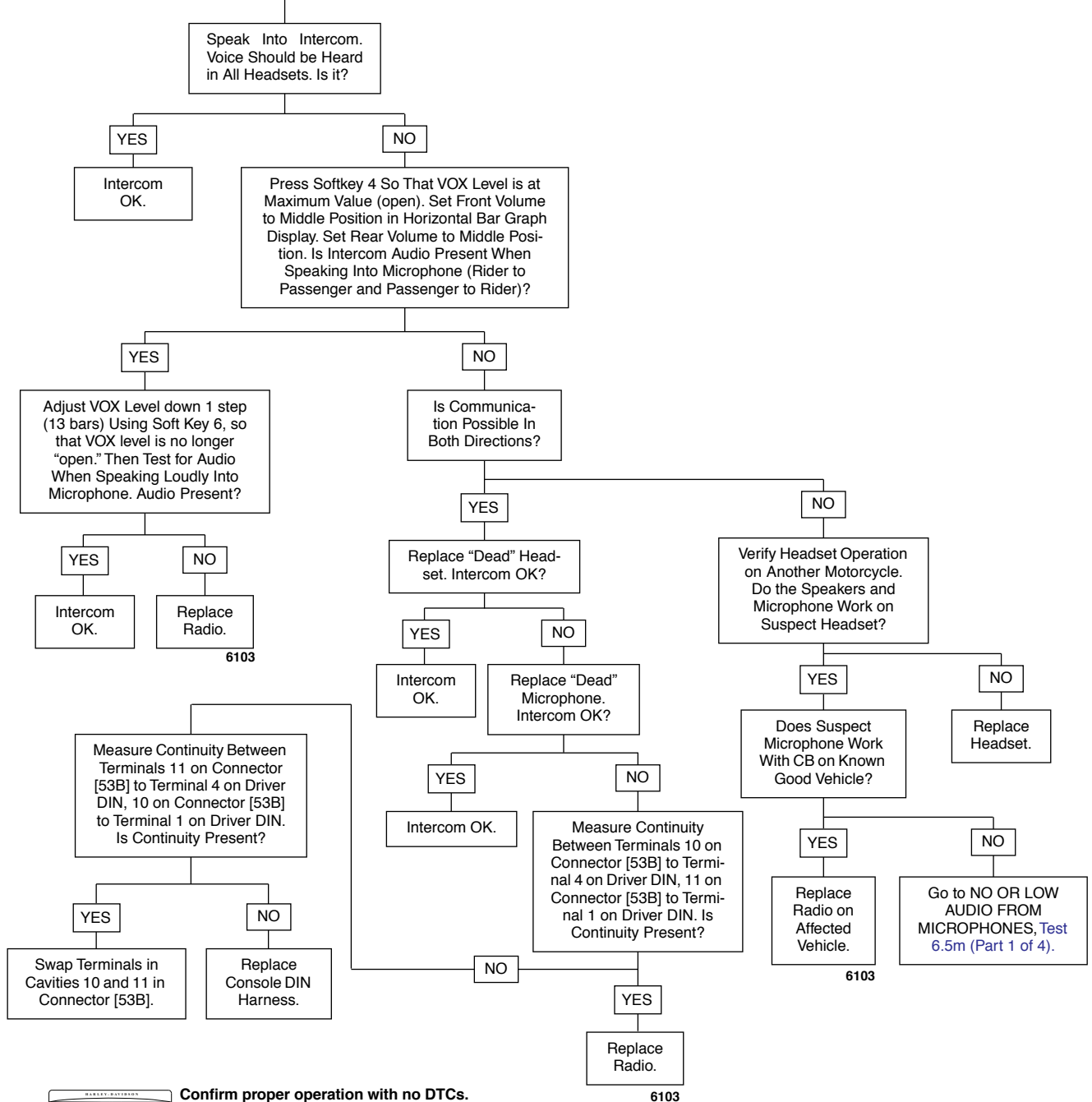

Confirm proper operation with no DTCs.

6103

Test 6.5j (Part 1 of 2)

HANDHELD MICROPHONE/PTT INOPERATIVE: SYMPTOM 10

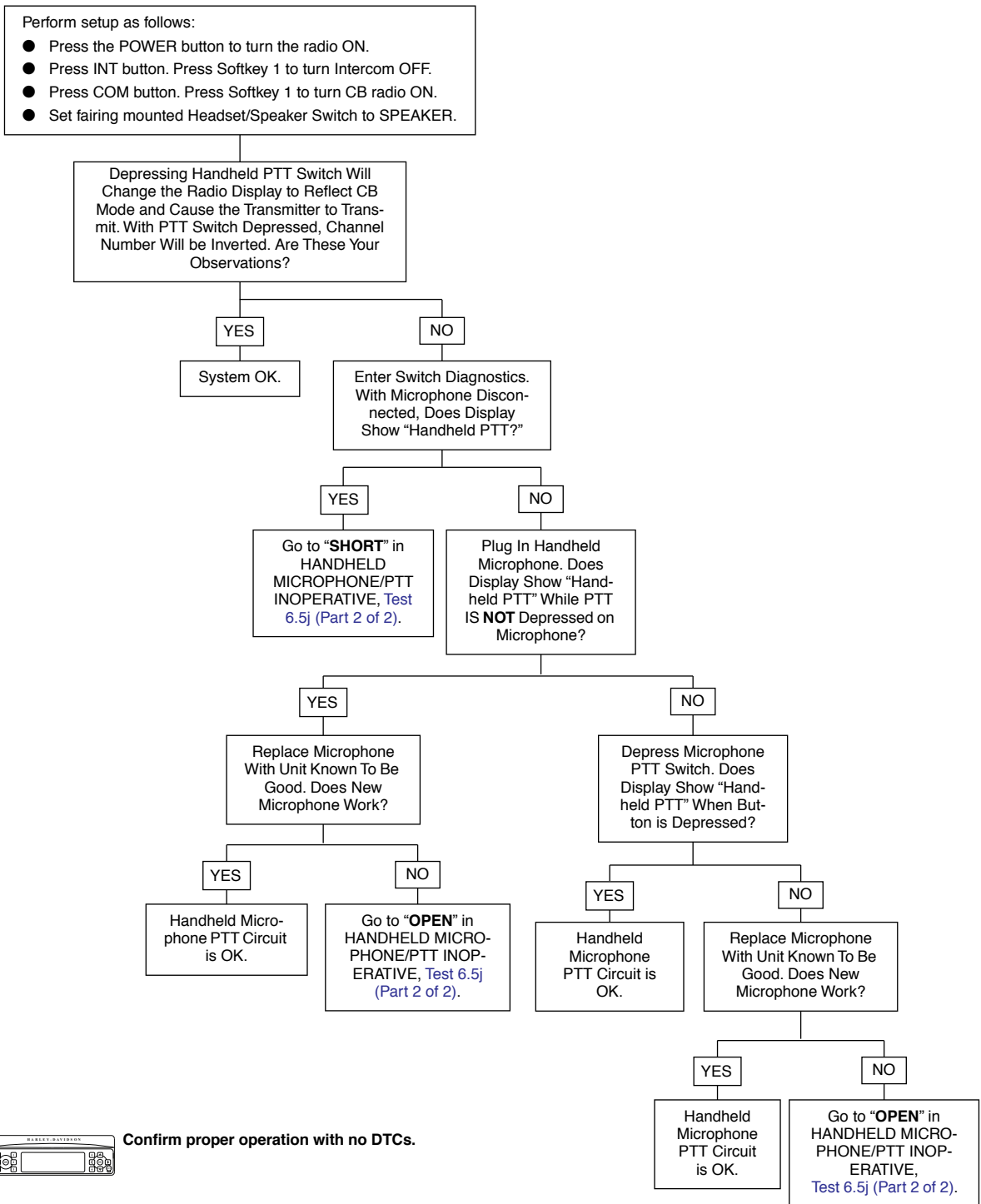

Test 6.5j (Part 2 of 2)

HANDHELD MICROPHONE/PTT INOPERATIVE: SYMPTOM 10

NOTE

See *Diagnostic Notes* on Page 6-61.

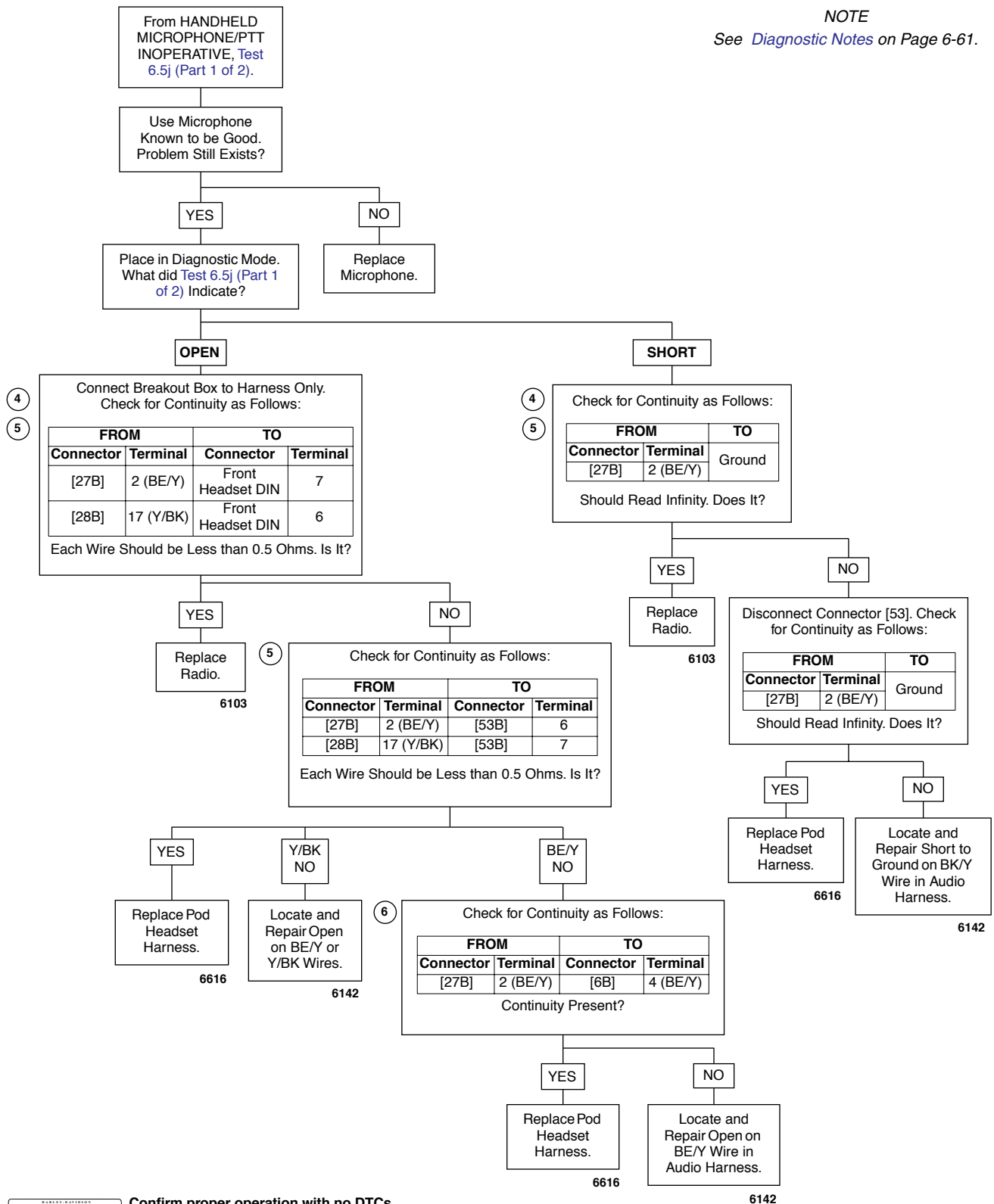

Confirm proper operation with no DTCs.

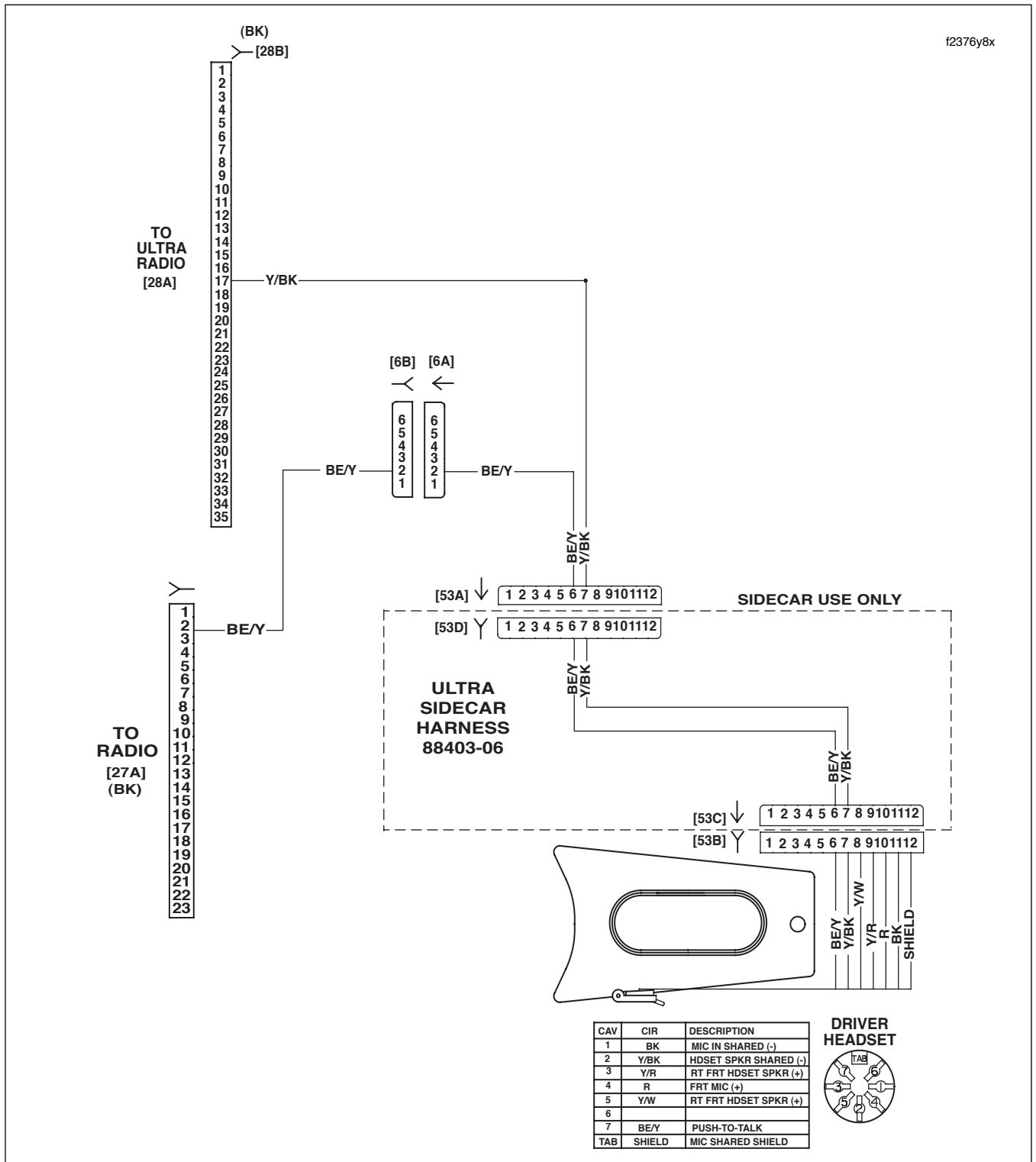

Figure 6-36. Handheld Microphone/PTT Circuit

Table 6-37. FLHTCU Wire Harness Connectors

NO.	DESCRIPTION	TYPE	LOCATION
[6]	Audio to Interconnect Harness	6-Place Deutsch (Black)	Inner Fairing - Top of Radio (Left Side)
[27]	Radio	23-Place Amp	Inner Fairing - Back of Radio (Right Side)
[28]	Radio	35-Place Amp	Inner Fairing - Back of Radio (Left Side)
[53]	Console Pod	12-Place Mini-Deutsch	Rear of Battery Box (Under Seat)

Test 6.5k

SPEAKER SWITCH MALFUNCTION: SYMPTOM 11

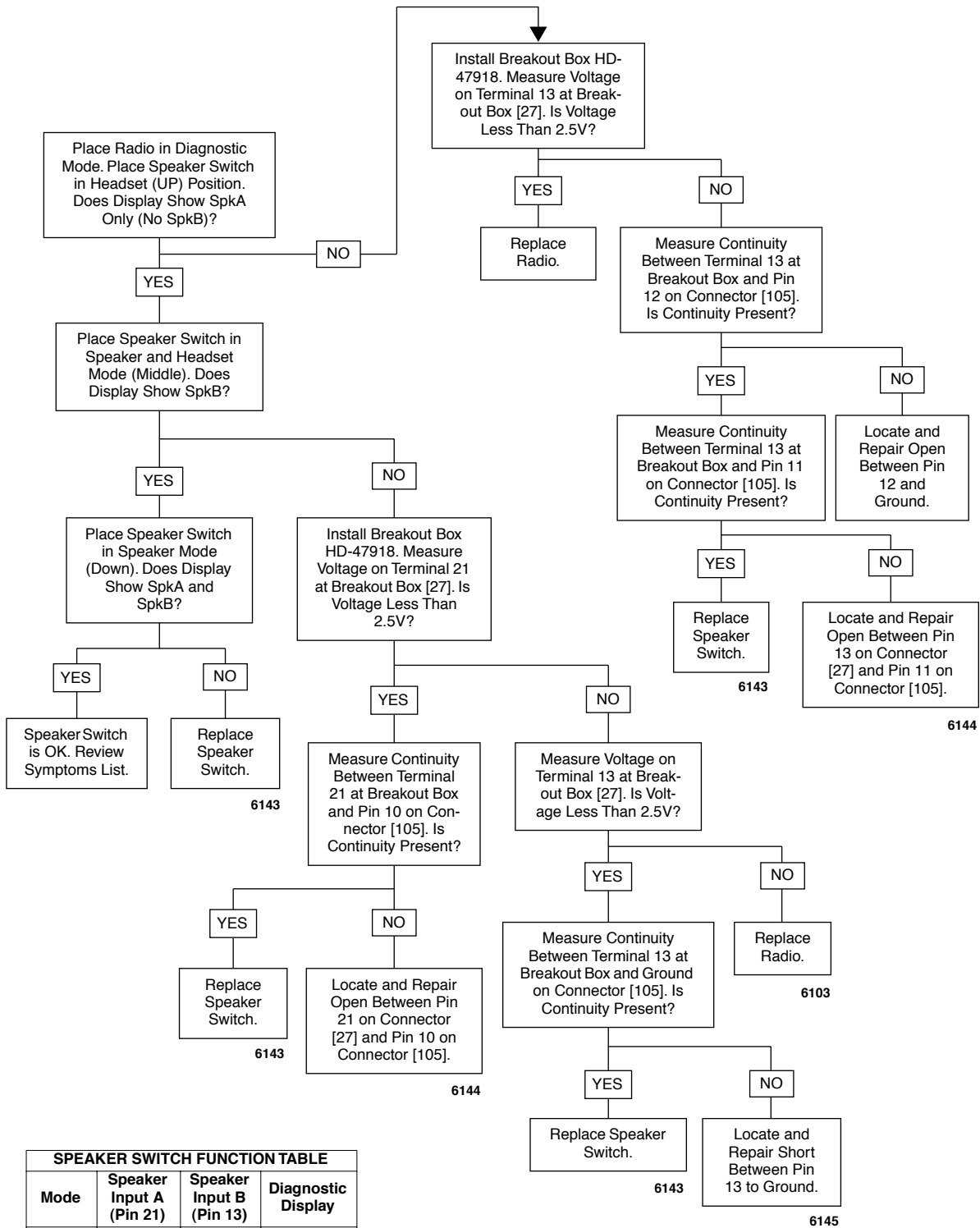

Mode	Speaker Input A (Pin 21)	Speaker Input B (Pin 13)	Diagnostic Display
Headset	Battery Voltage	0-1 VDC	SpkA
Speaker/Headset	0-1 VDC	4.5-5.5 VDC	SpkB
Speaker	Battery Voltage	4.5-5.5 VDC	SpkA SpkB



Confirm proper operation with no DTCs.

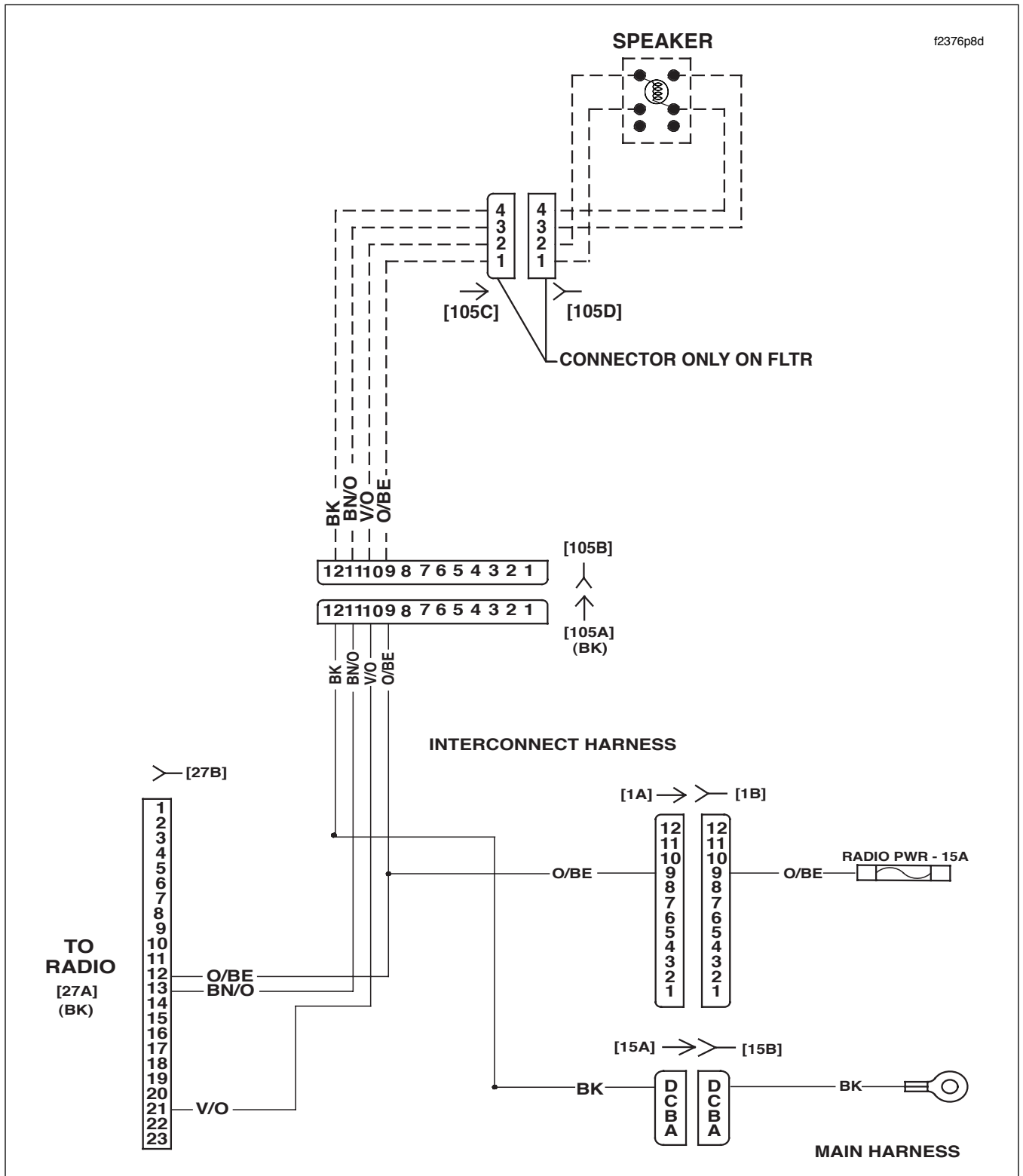

Figure 6-37. Speaker Switch Circuit

Table 6-38. FLHTCU Wire Harness Connectors

NO.	DESCRIPTION	TYPE	LOCATION
[1]	Main to Interconnect Harness	12-Place Deutsch	Inner Fairing - Right Radio Support Bracket
[15]	Main to Interconnect Harness	4-Place Packard	Inner Fairing - Right Fairing Bracket
[27]	Radio	23-Place Amp	Inner Fairing - Back of Radio (Right Side)
[105]	Fairing Cap Switches	12-Place Multilock	Inner Fairing - Above Upper Fork Bracket (Right Side)

Test 6.5I (Part 1 of 5)

HEADSET SPEAKERS INOPERATIVE: SYMPTOM 12

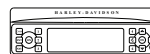
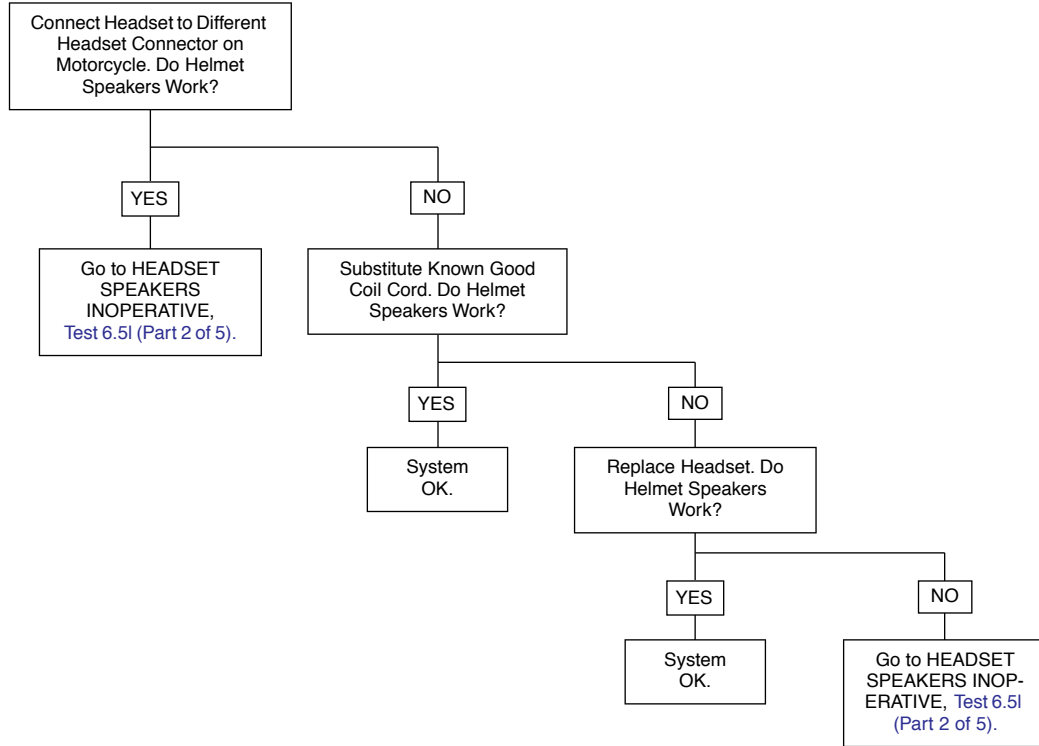

Confirm proper operation with no DTCs.

Test 6.5l (Part 2 of 5)

HEADSET SPEAKERS INOPERATIVE: SYMPTOM 12

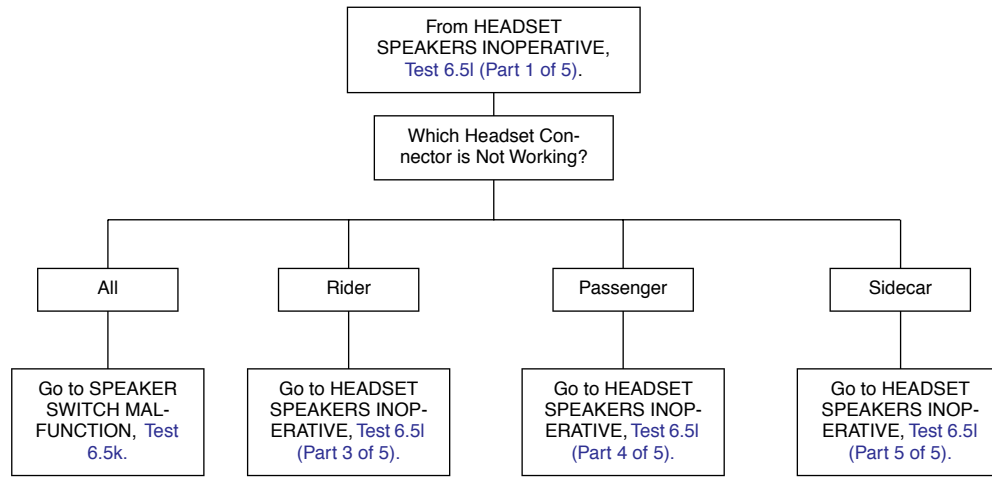

Confirm proper operation with no DTCs.

Test 6.5I (Part 3 of 5)

HEADSET SPEAKERS INOPERATIVE: SYMPTOM 12

NOTE

See *Diagnostic Notes* on Page 6-61.

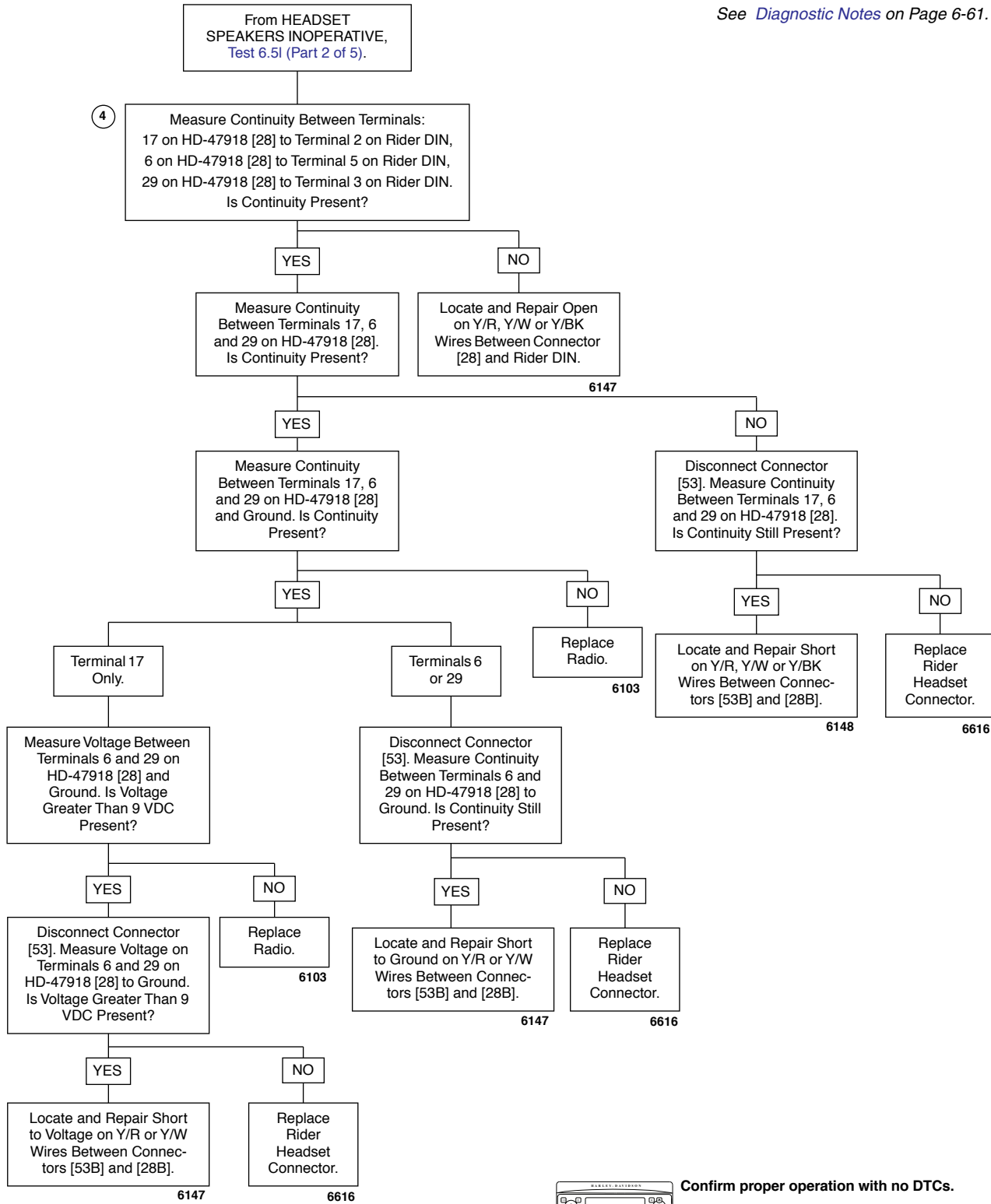

Confirm proper operation with no DTCs.

Test 6.5I (Part 4 of 5)

HEADSET SPEAKERS INOPERATIVE: SYMPTOM 12

NOTE
See *Diagnostic Notes* on Page 6-61.

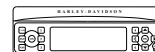
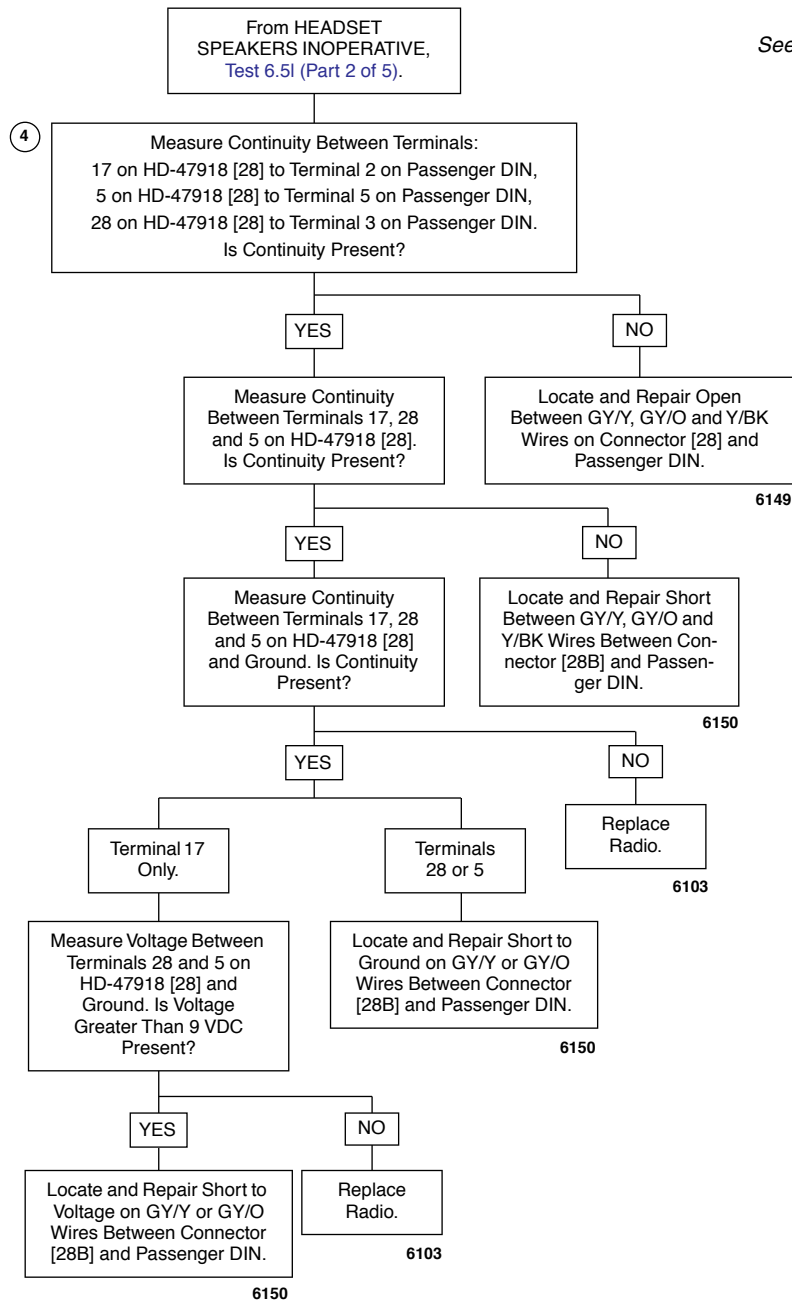

Confirm proper operation with no DTCs.

Test 6.5I (Part 5 of 5)

HEADSET SPEAKERS INOPERATIVE: SYMPTOM 12

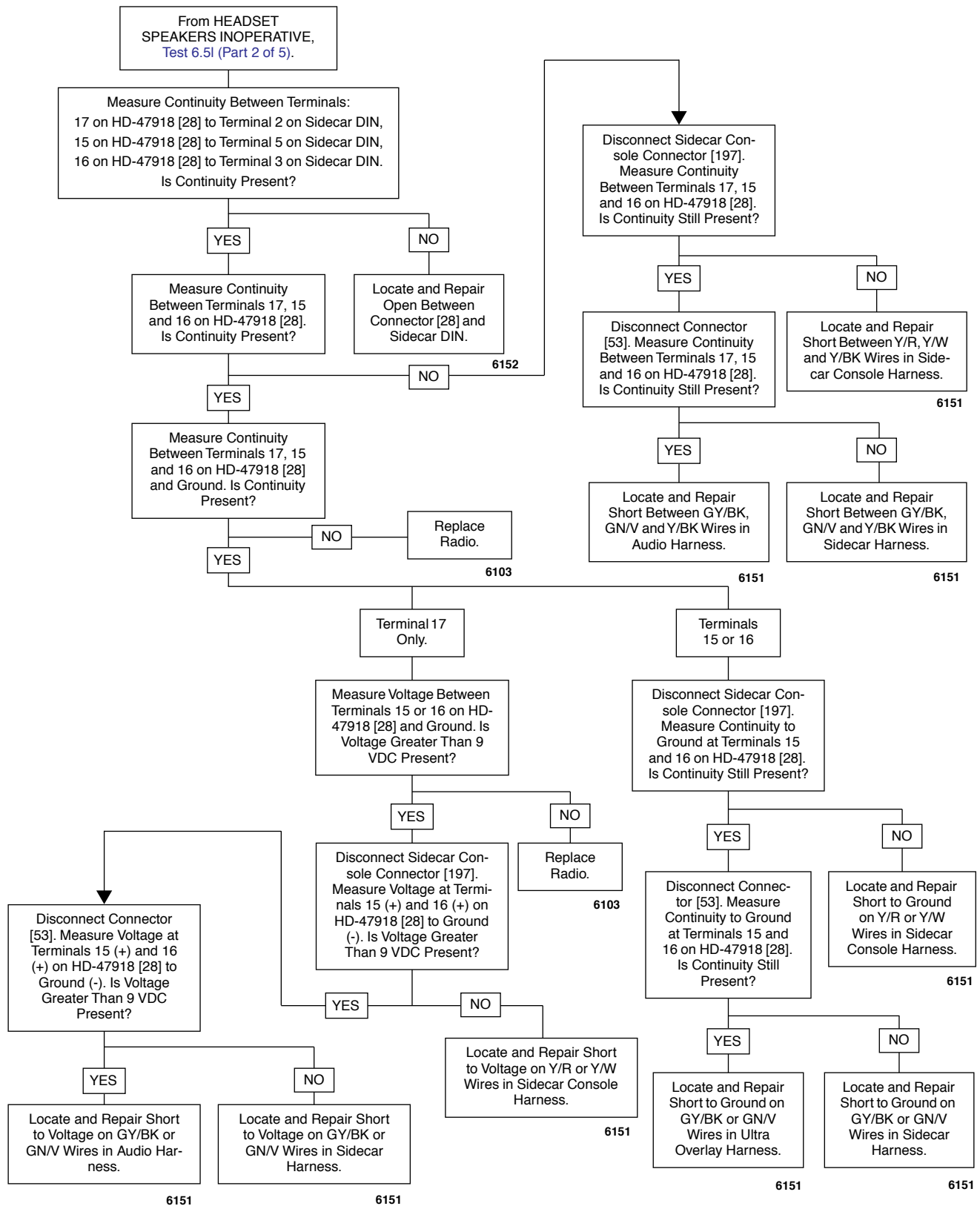

Confirm proper operation with no DTCs.

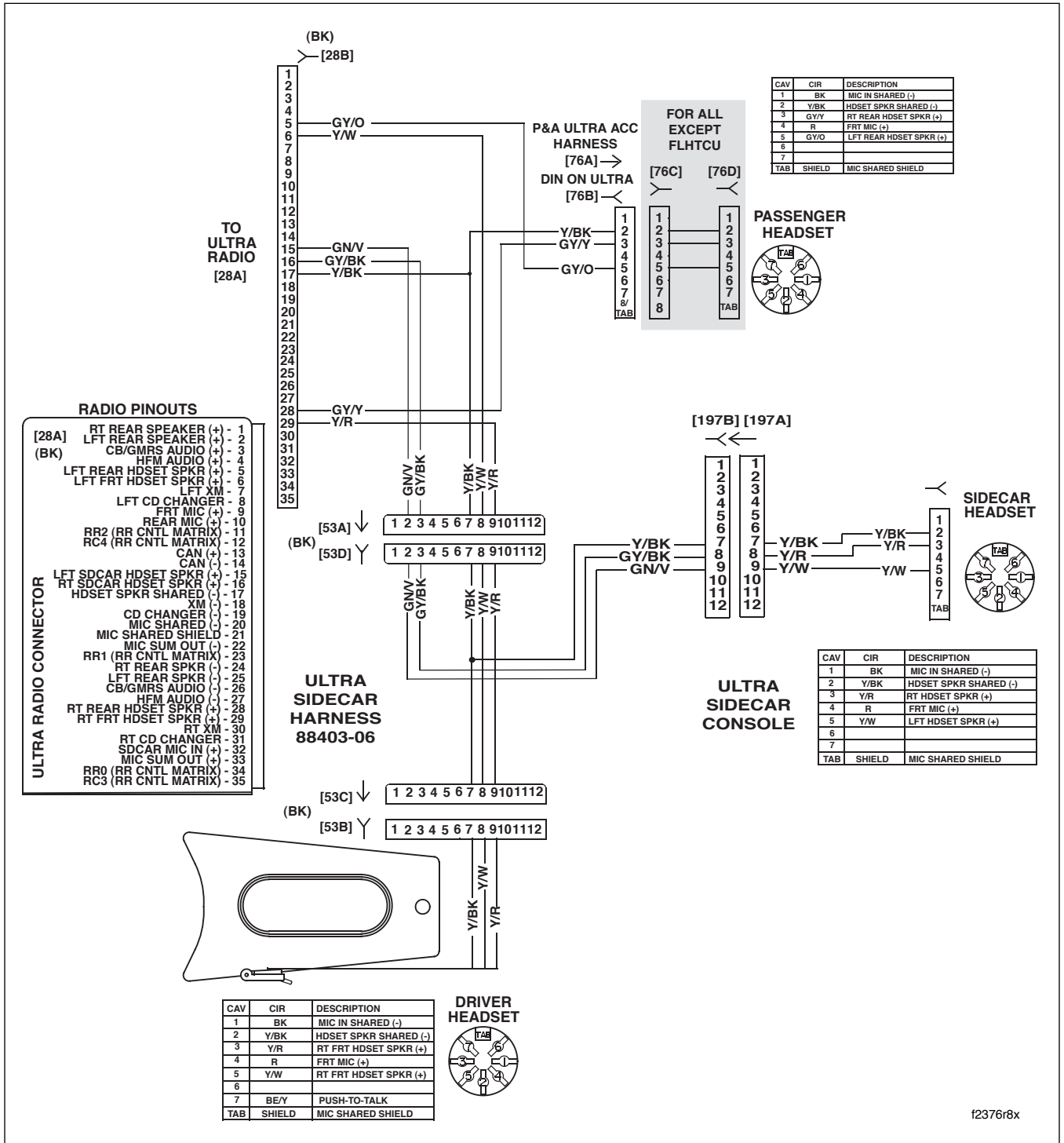

Figure 6-38. Headset Speaker Circuit

Table 6-39. FLHTCU Wire Harness Connectors

NO.	DESCRIPTION	TYPE	LOCATION
[28]	Radio	35-Place Amp	Inner Fairing - Back of Radio (Left Side)
[53]	Console Pod	12-Place Mini-Deutsch	Rear of Battery Box (Under Seat)
[197]	Sidecar Console	12-Place Mini-Deutsch	Inside Sidecar Console

Test 6.5m (Part 1 of 4)

NO OR LOW AUDIO FROM MICROPHONES: SYMPTOM 13

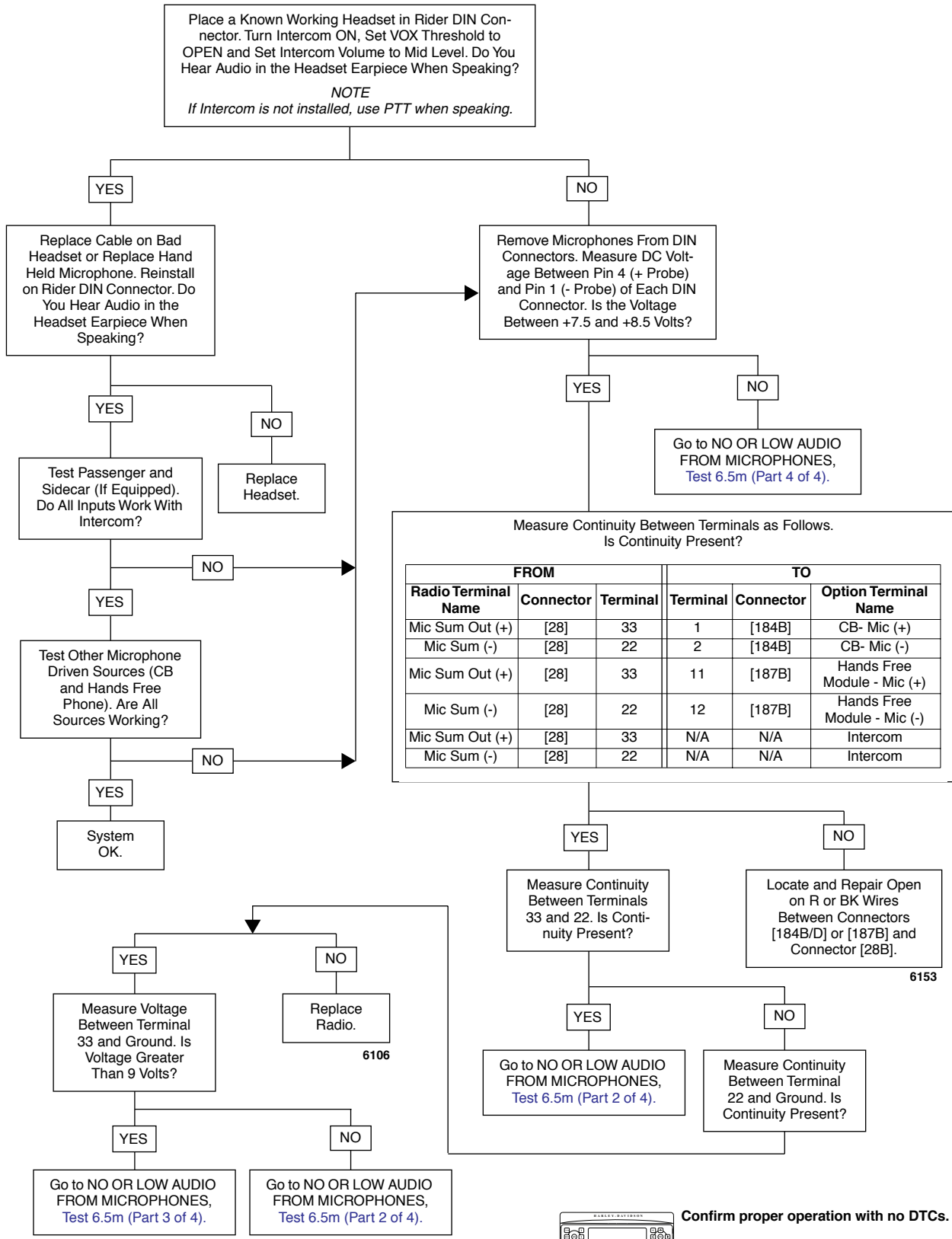

Confirm proper operation with no DTCs.

Test 6.5m (Part 2 of 4)

NO OR LOW AUDIO FROM MICROPHONES: SYMPTOM 13

NOTE
See *Diagnostic Notes* on Page 6-61.

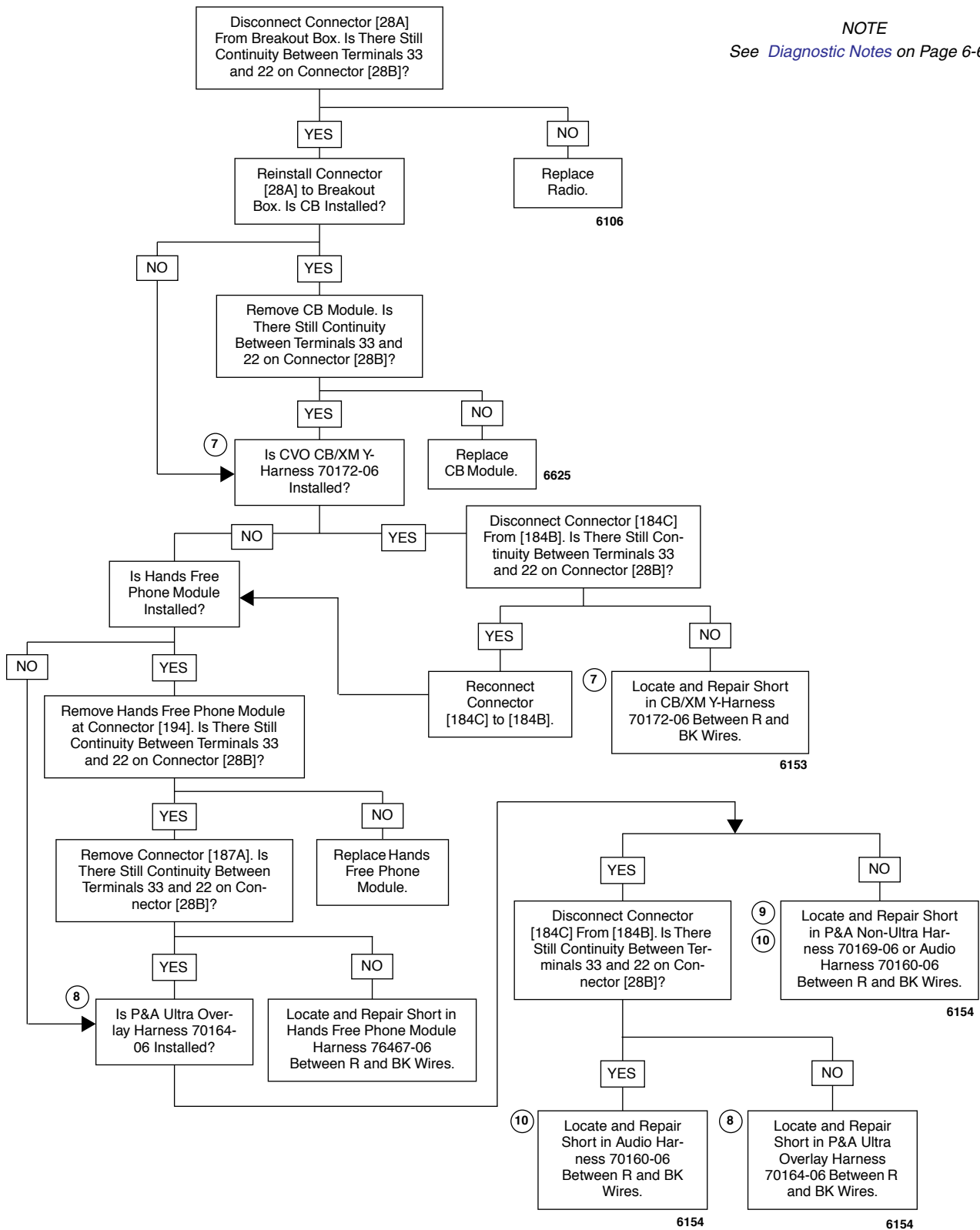

Confirm proper operation with no DTCs.

Test 6.5m (Part 3 of 4)

NO OR LOW AUDIO FROM MICROPHONES: SYMPTOM 13

NOTE
See *Diagnostic Notes* on Page 6-61.

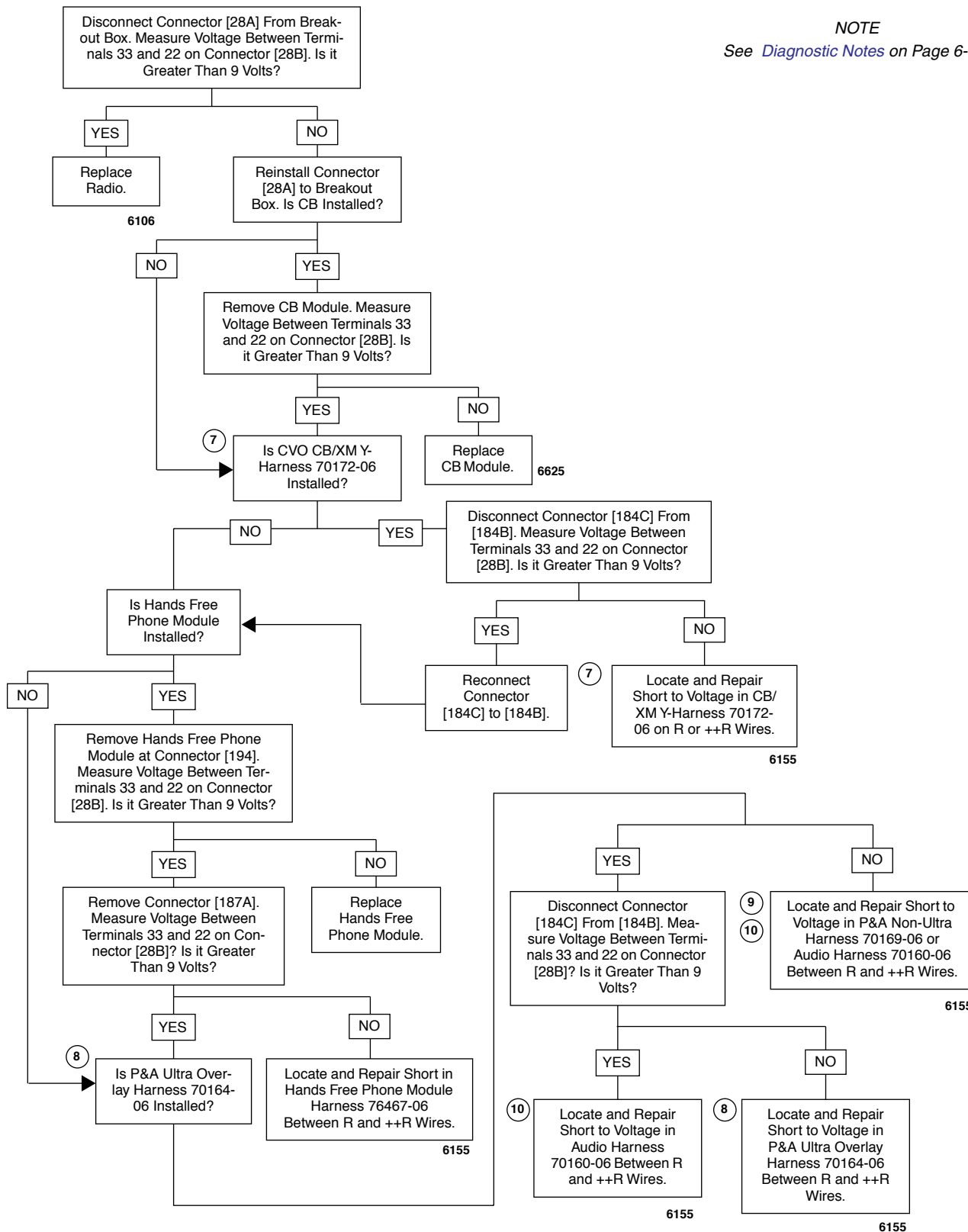

Confirm proper operation with no DTCs.

Test 6.5m (Part 4 of 4)

NO OR LOW AUDIO FROM MICROPHONES: SYMPTOM 13

Remove All Microphones/Headsets. Measure Continuity Between Terminals as Follows.

Function	FROM		TO	
	Connector	Terminal	Connector	Terminal
Shield	Rider DIN	Tab	[28B]	21
Mic (+)	Rider DIN	4	[28B]	9
Mic (-)	Rider DIN	1	[28B]	20
Shield	Passenger DIN	Tab	[28B]	21
Mic (+)	Passenger DIN	4	[28B]	10
Mic (-)	Passenger DIN	1	[28B]	20
Shield	Sidecar DIN	Tab	[28B]	21
Mic (+)	Sidecar DIN	4	[28B]	32
Mic (-)	Sidecar DIN	1	[28B]	20

Is Continuity Present?

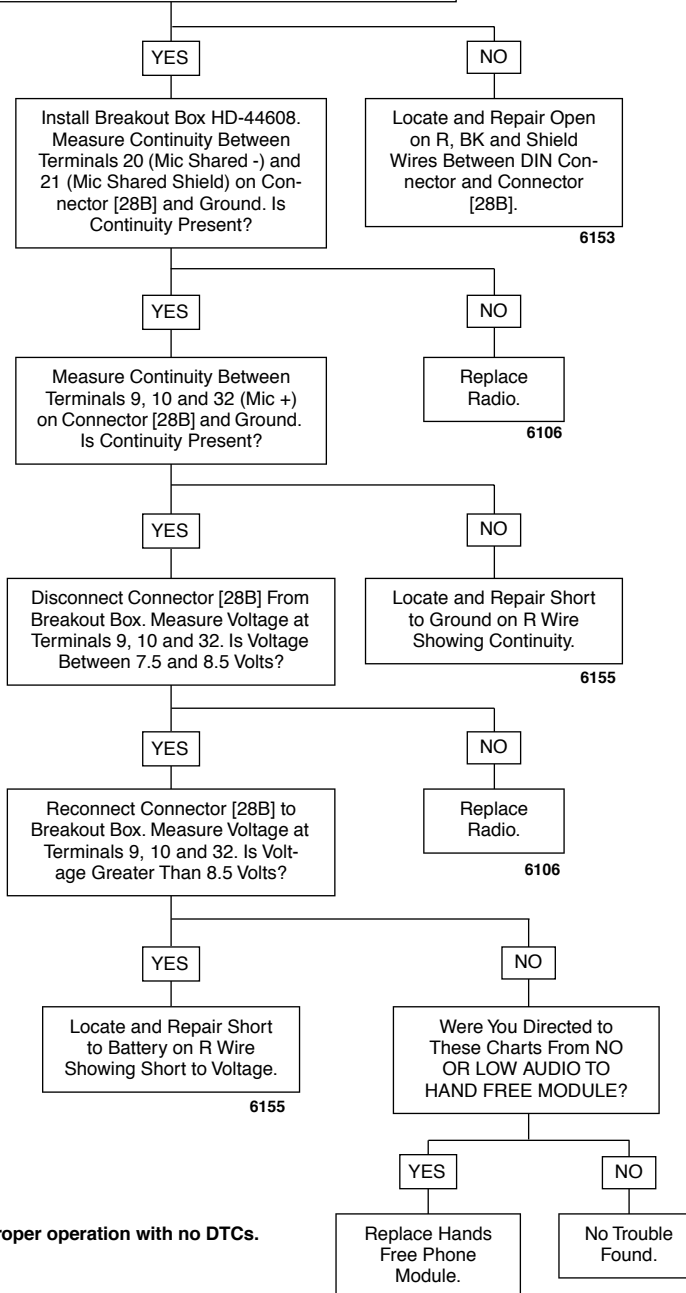

Confirm proper operation with no DTCs.

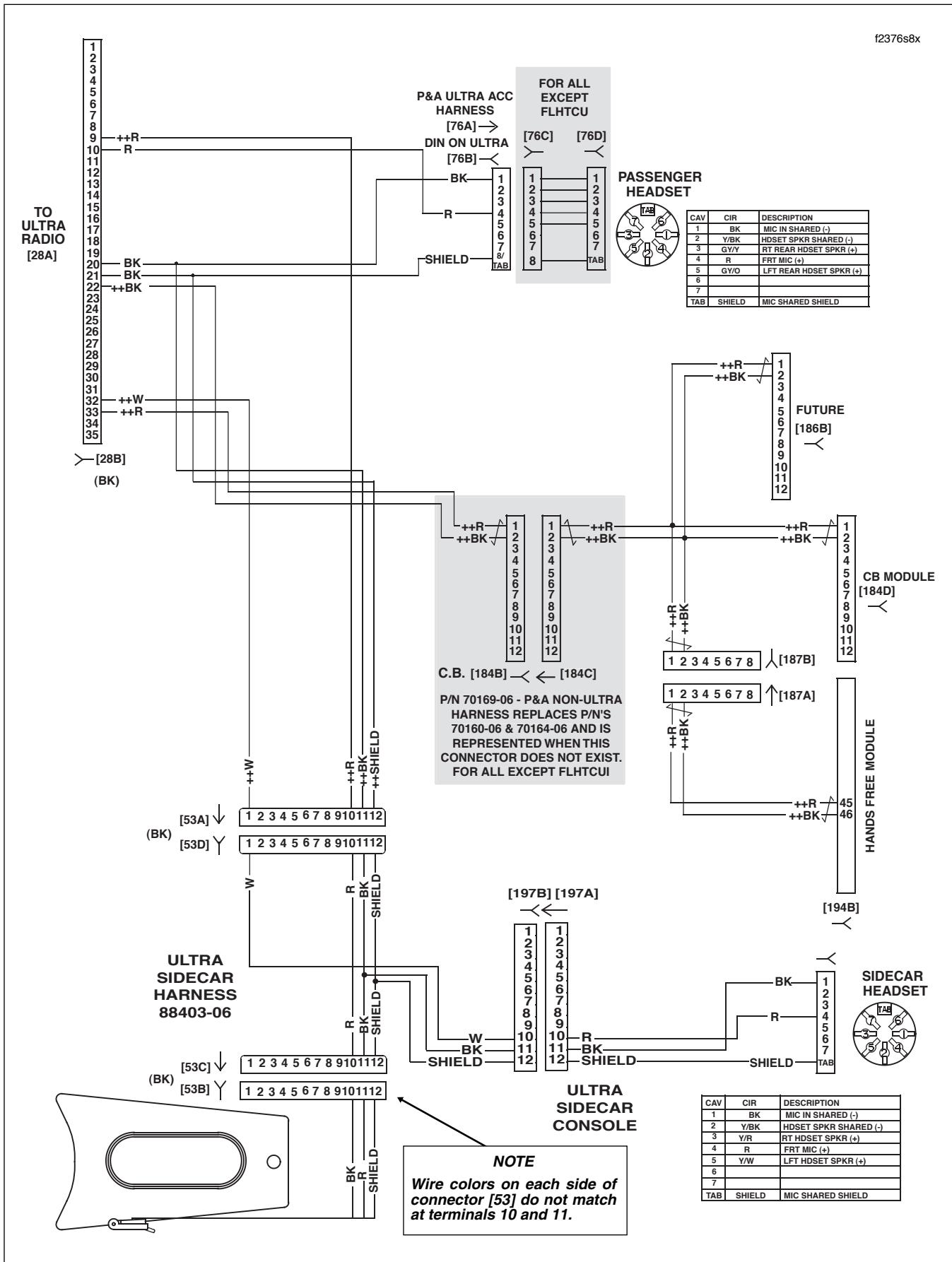
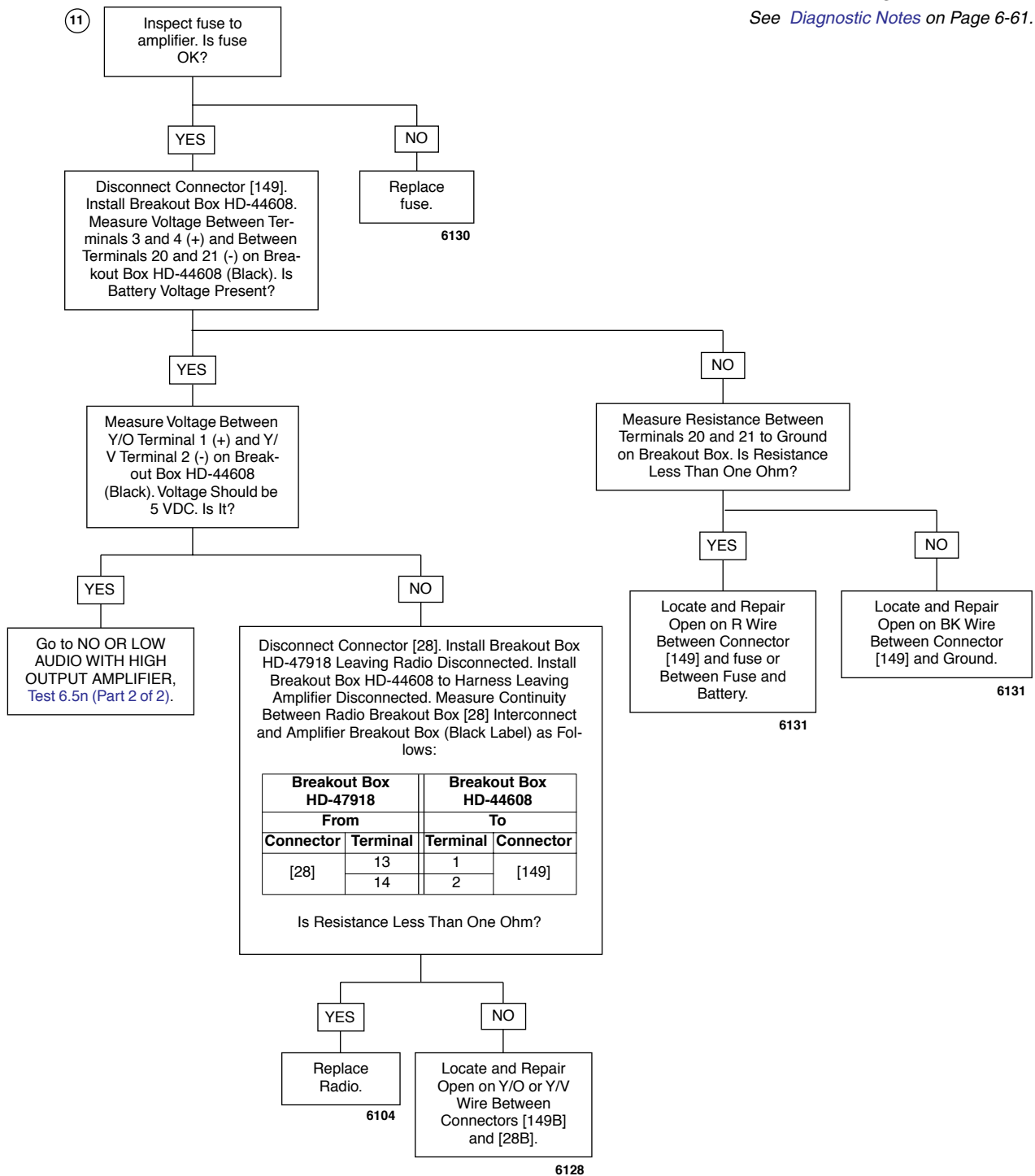

Figure 6-39. Microphone Audio Input Circuit

Test 6.5n (Part 1 of 2)

NO OR LOW AUDIO WITH HIGH OUTPUT AMPLIFIER: SYMPTOM 14

NOTE
See *Diagnostic Notes* on Page 6-61.



Confirm proper operation with no DTCs.

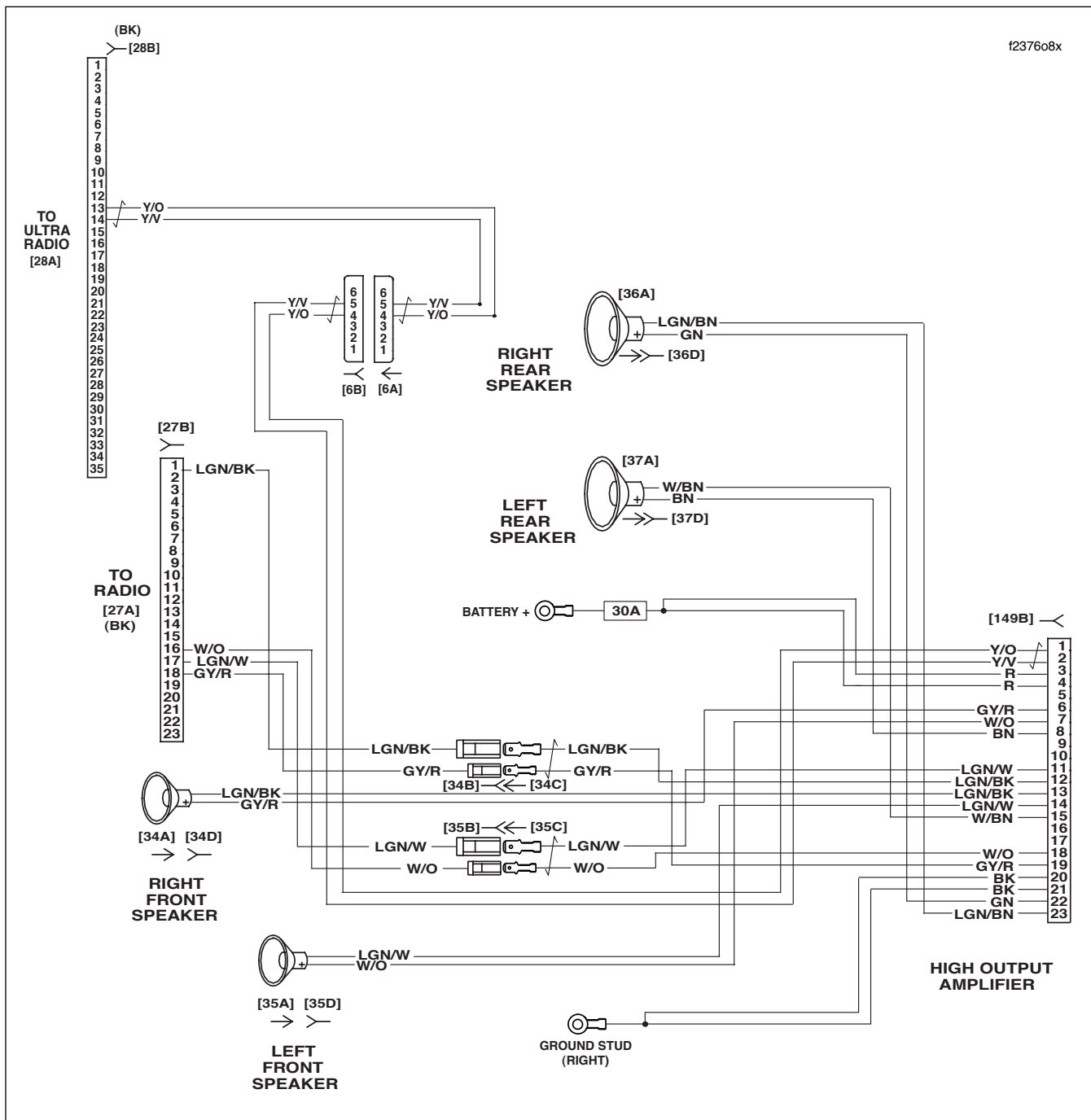

Figure 6-40. Front/Rear Speaker Circuits With Amplifier

Table 6-40. FLHTCU Wire Harness Connectors

NO.	DESCRIPTION	TYPE	LOCATION
[6]	Audio to Interconnect Harness	6-Place Deutsch (Black)	Inner Fairing - Top of Radio (Left Side)
[27]	Radio	23-Place Amp	Inner Fairing - Back of Radio (Right Side)
[28]	Radio	35-Place Amp	Inner Fairing - Back of Radio (Left Side)
[34]	Front Right Speaker	Spade Contacts	Inner Fairing - Back of Right Speaker
[35]	Front Left Speaker	Spade Contacts	Inner Fairing - Back of Left Speaker
[36]	Rear Right Speaker	Spade Contacts	Inside Speaker Box
[37]	Rear Left Speaker	Spade Contacts	Inside Speaker Box
[149]	High Output Amplifier	23-Place Amp	Under Luggage Rack (Right Side)

Test 6.5n (Part 2 of 2)

NO OR LOW AUDIO WITH HIGH OUTPUT AMPLIFIER: SYMPTOM 14

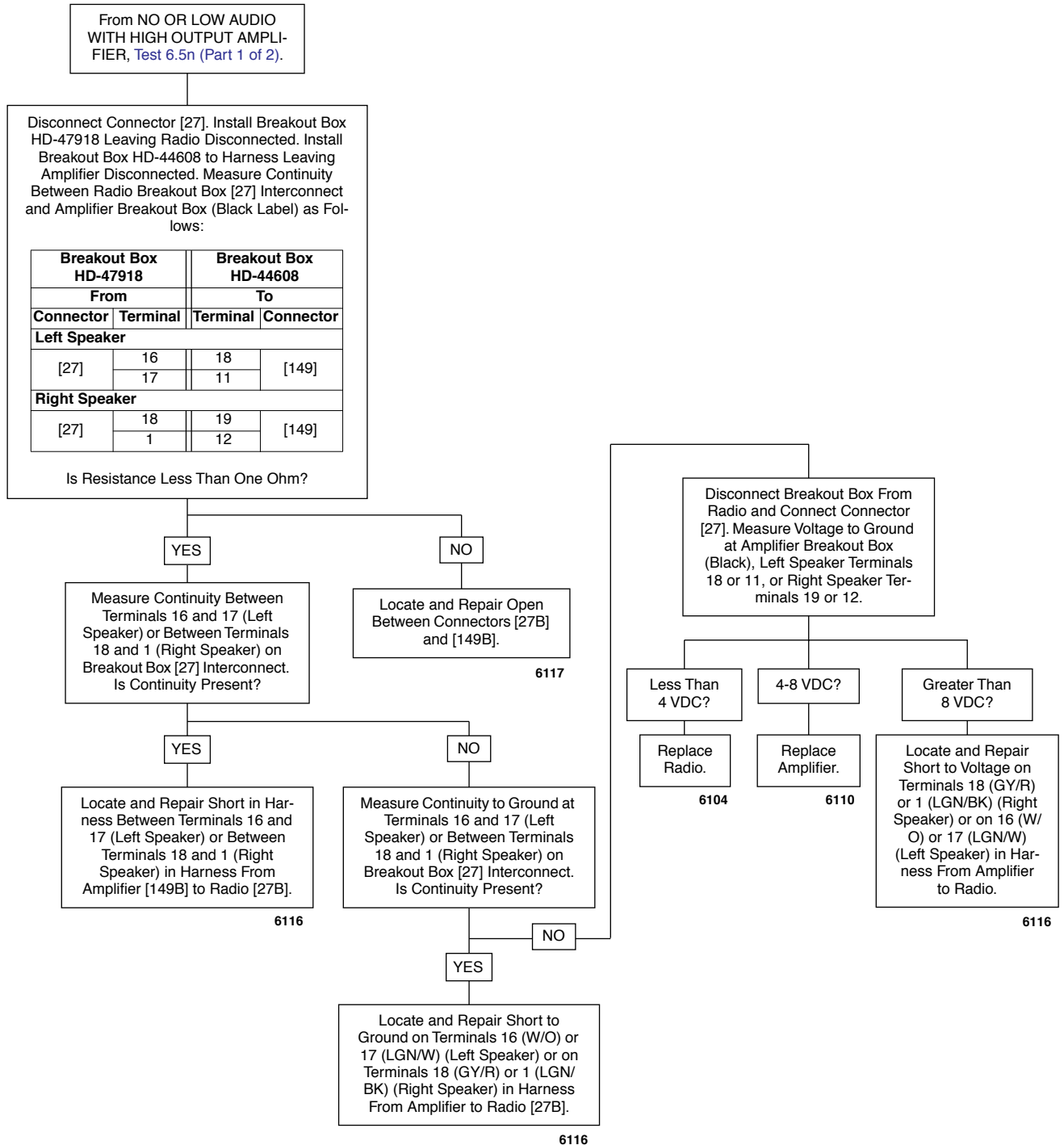

Confirm proper operation with no DTCs.

Test 6.5o (Part 1 of 2)

NO OR LOW AUDIO FROM XM OR XM INOPERATIVE: SYMPTOM 15

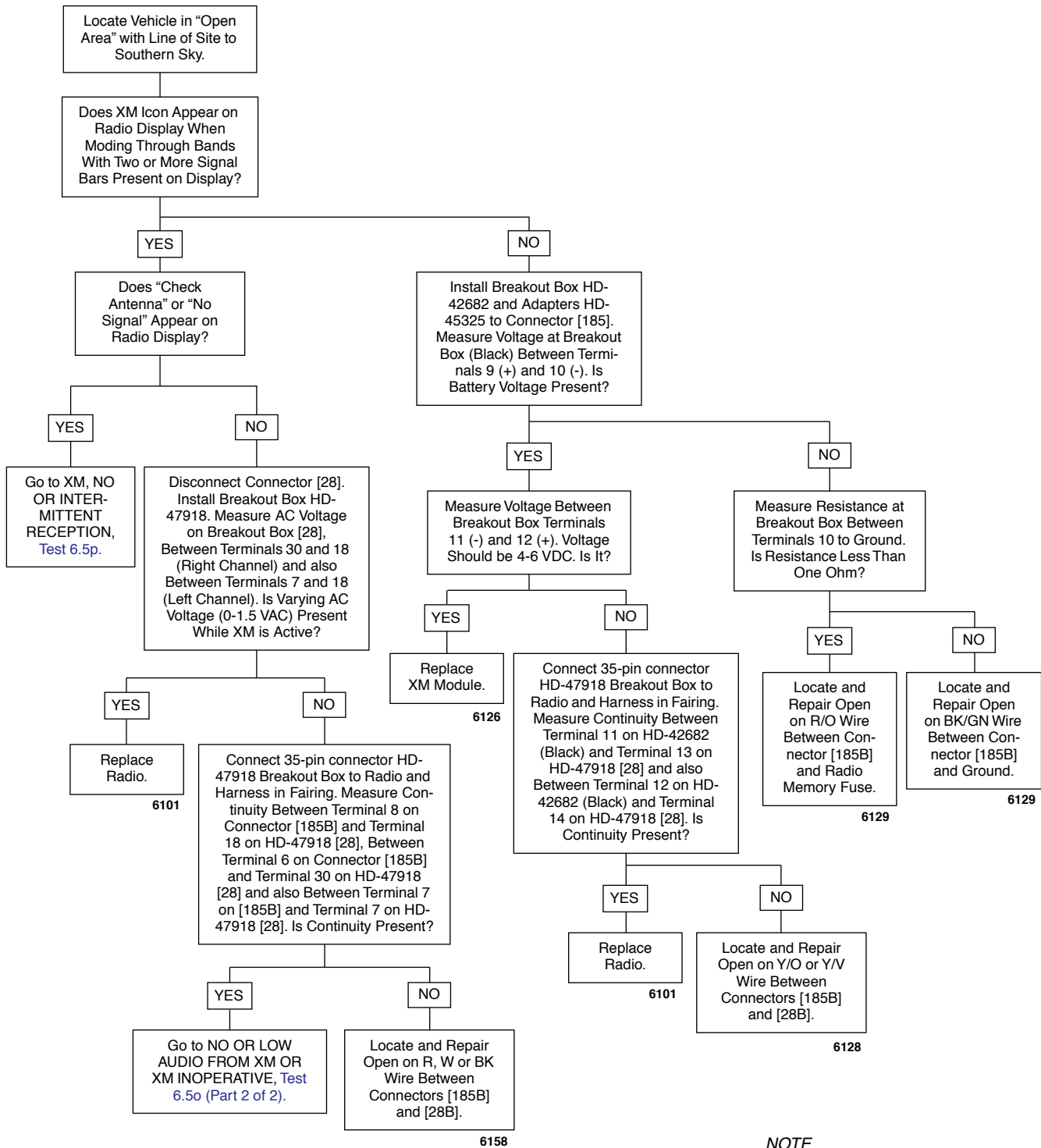

NOTE
XM Available in U.S. Only.



Confirm proper operation with no DTCs.

Test 6.5o (Part 2 of 2)

NO OR LOW AUDIO FROM XM OR XM INOPERATIVE: SYMPTOM 15

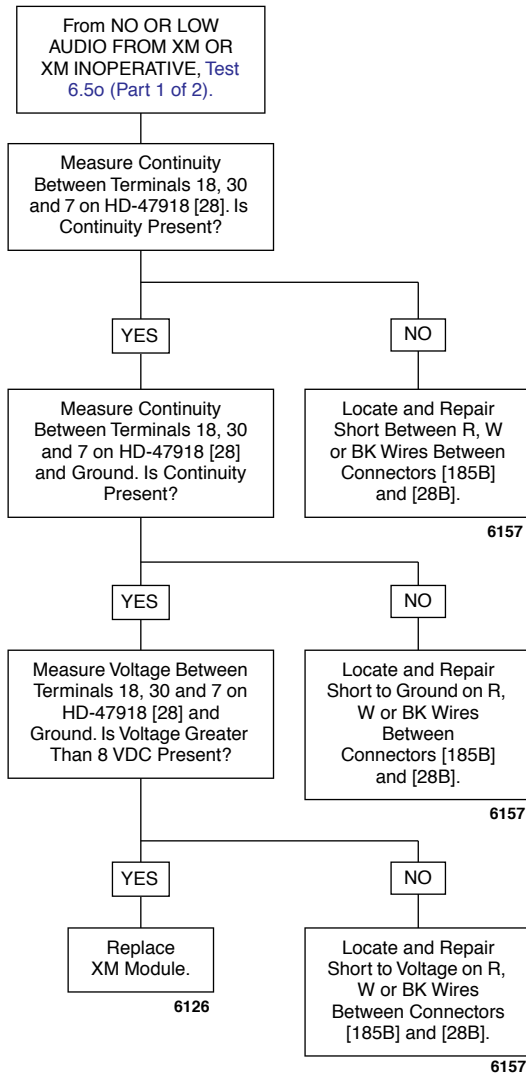

NOTE
XM Available in U.S. Only.



Confirm proper operation with no DTCs.

Table 6-41. FLHTCU Wire Harness Connectors

NO.	DESCRIPTION	TYPE	LOCATION
[6]	Audio to Interconnect Harness	6-Place Deutsch (Black)	Inner Fairing - Top of Radio (Left Side)
[15]	Main to Interconnect Harness	4-Place Packard	Inner Fairing - Right Fairing Bracket
[27]	Radio	23-Place Amp	Inner Fairing - Back of Radio (Right Side)
[28]	Radio	35-Place Amp	Inner Fairing - Back of Radio (Left Side)
[184]	CB Module	12-Place Mini-Deutsch	Inner Fairing - Top of Radio (Left Side)
[185]	XM Module	12-Place Mini-Deutsch	Inner Fairing - Top of Radio (Left Side)

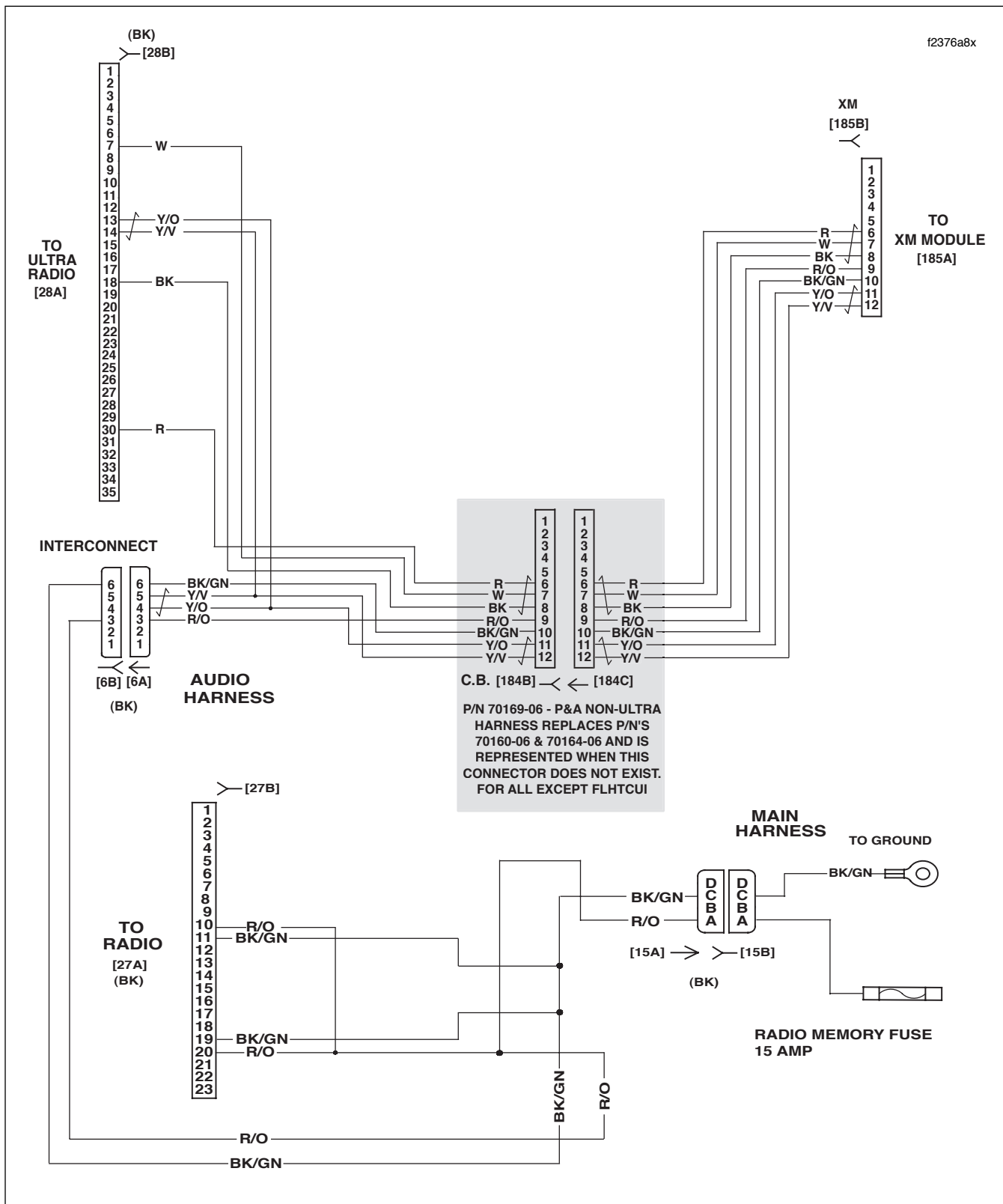
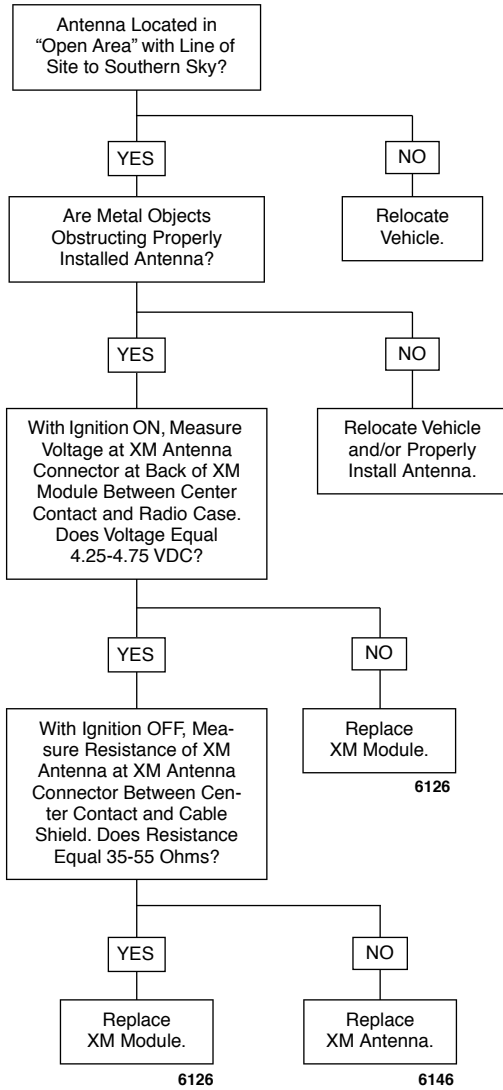

Figure 6-41. XM Circuit

Test 6.5p

XM - NO OR INTERMITTENT RECEPTION: SYMPTOM 16



Confirm proper operation with no DTCs.

Test 6.5q (Part 1 of 2)

NAVIGATION INOPERATIVE: SYMPTOM 17

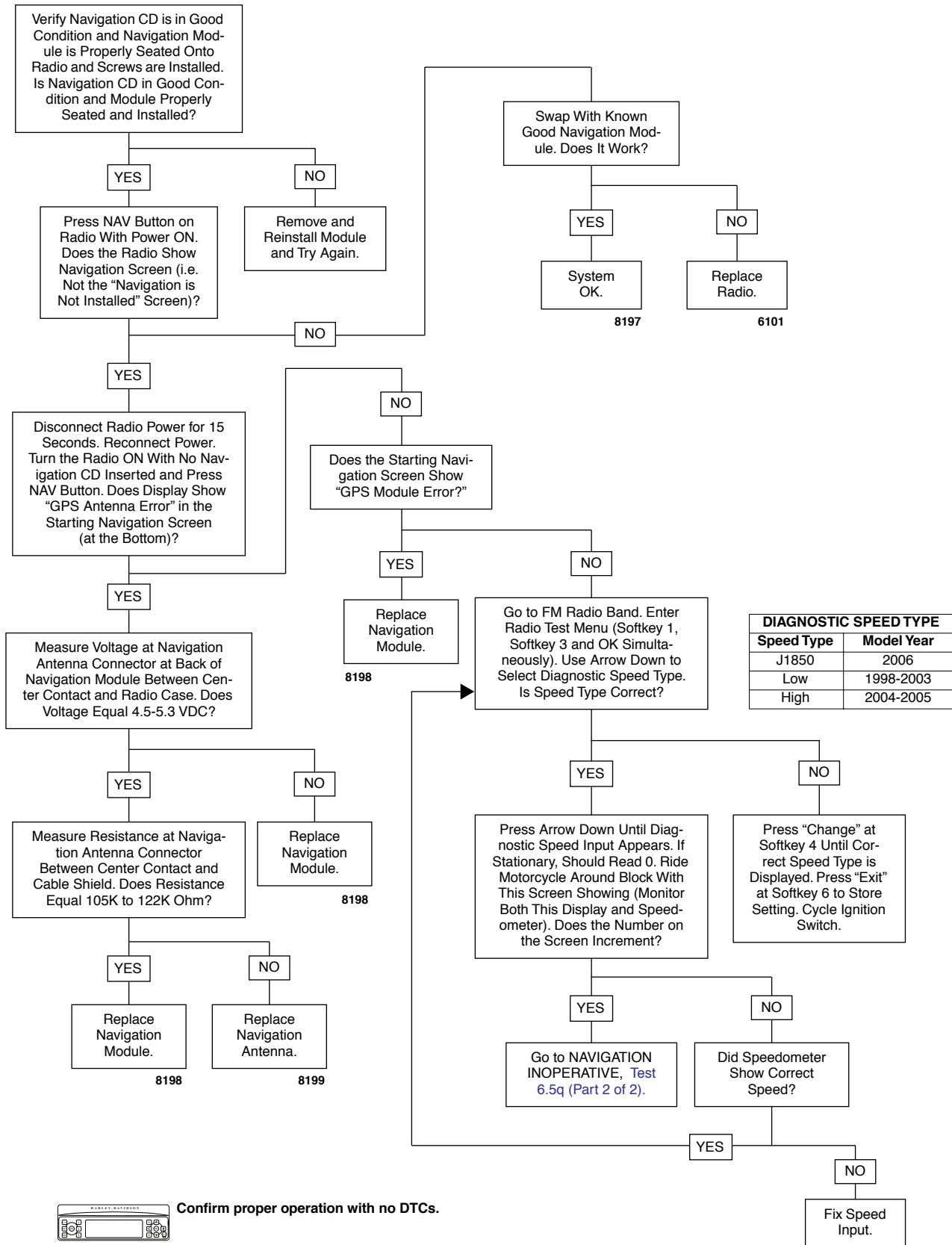

Confirm proper operation with no DTCs.

Test 6.5q (Part 2 of 2)

NAVIGATION INOPERATIVE: SYMPTOM 17

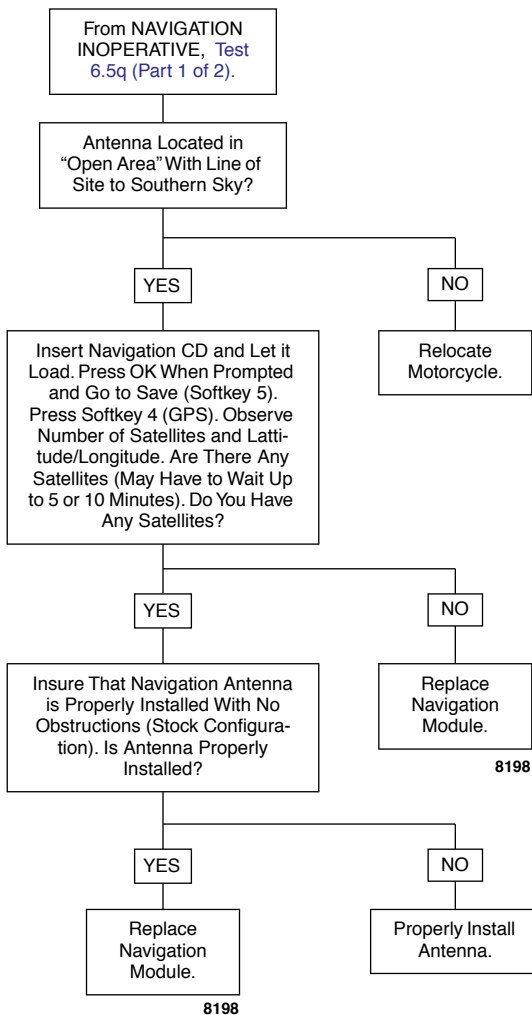

Confirm proper operation with no DTCs.

Test 6.5r

AVC INOPERATIVE: SYMPTOM 18

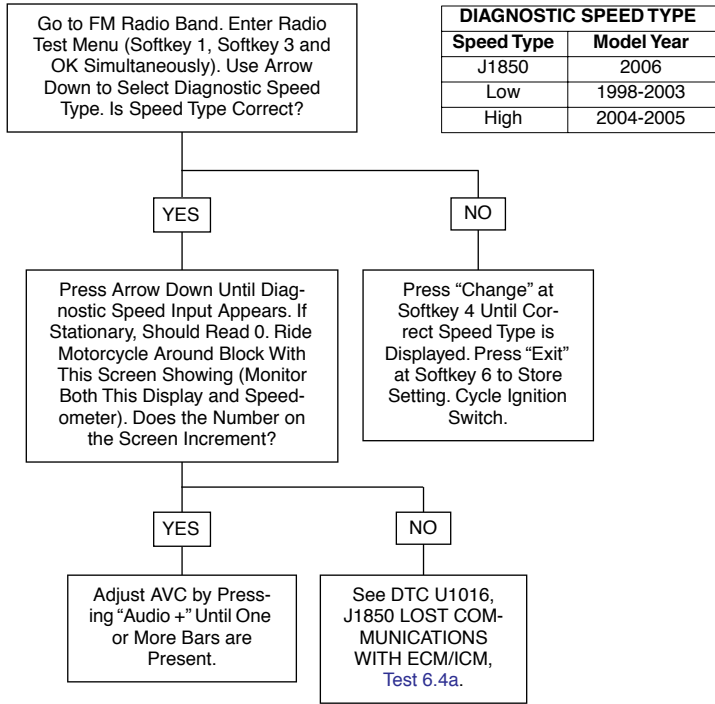

Confirm proper operation with no DTCs.

Test 6.5s (Part 1 of 4)

HANDLEBAR, PASSENGER OR SIDECAR SWITCHES INOPERATIVE: SYMPTOM 19

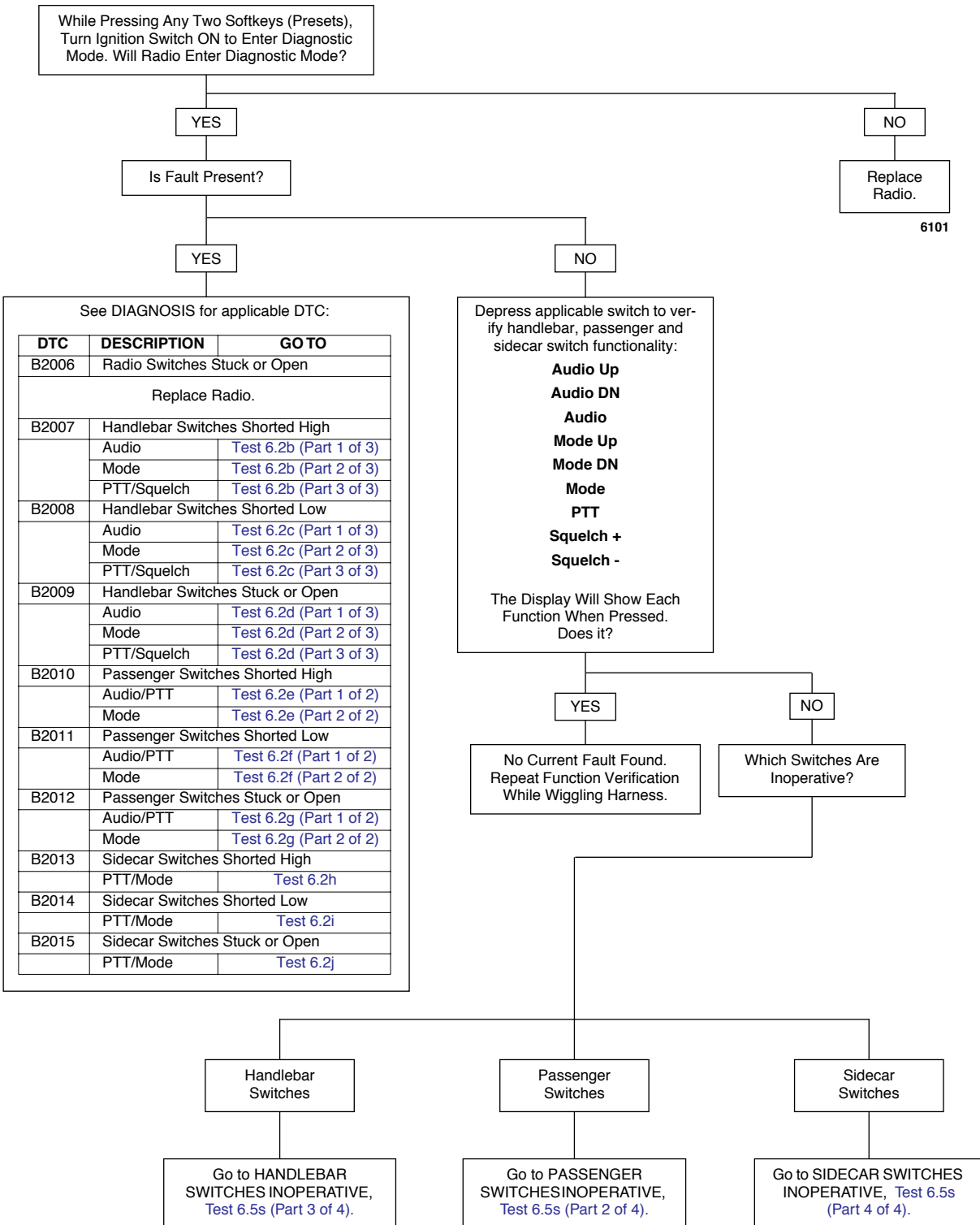

Confirm proper operation with no DTCs.

Test 6.5s (Part 2 of 4)

HANDLEBAR, PASSENGER OR SIDECAR SWITCHES INOPERATIVE: SYMPTOM 19

NOTE

See *Diagnostic Notes* on Page 6-61.

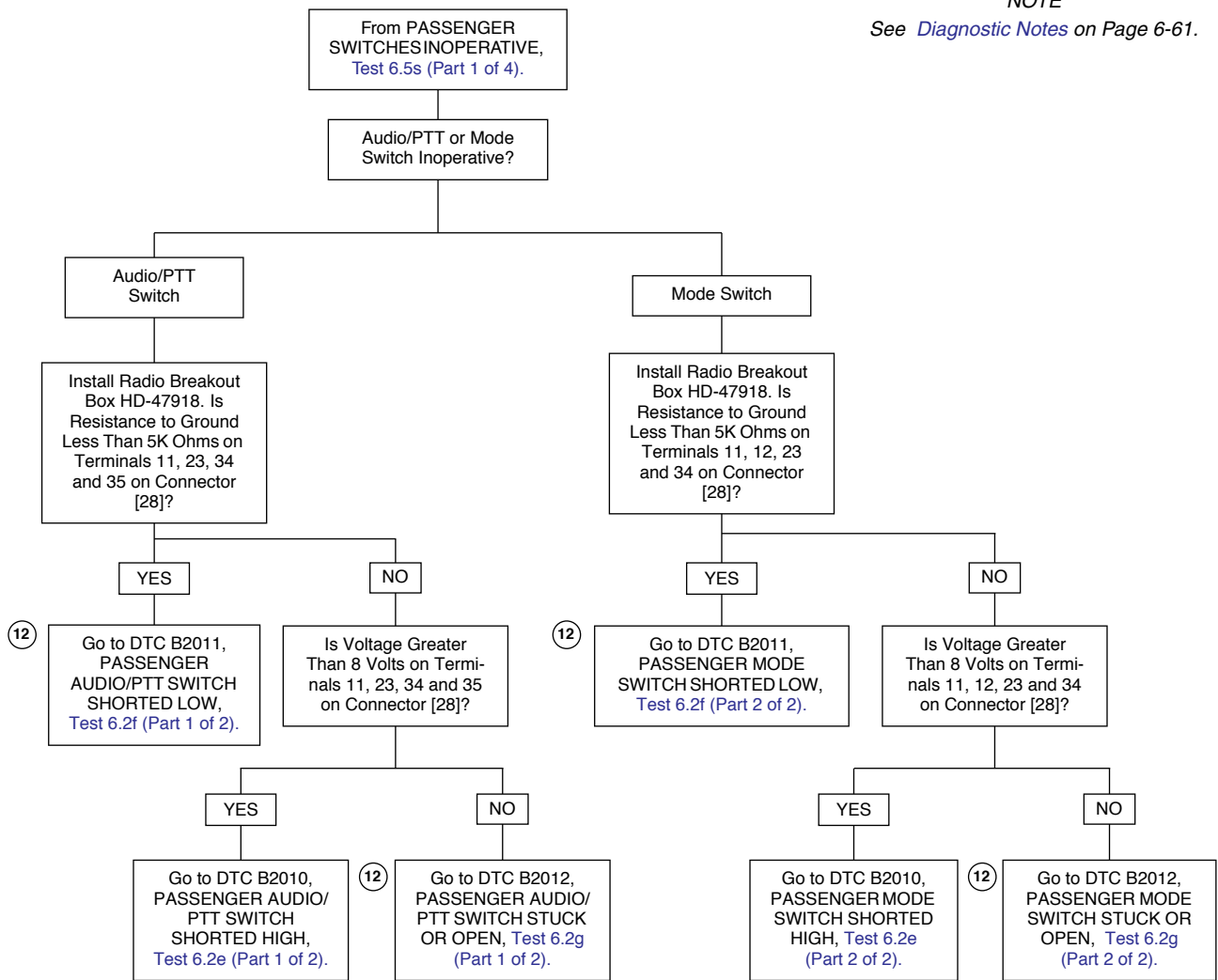

Confirm proper operation with no DTCs.

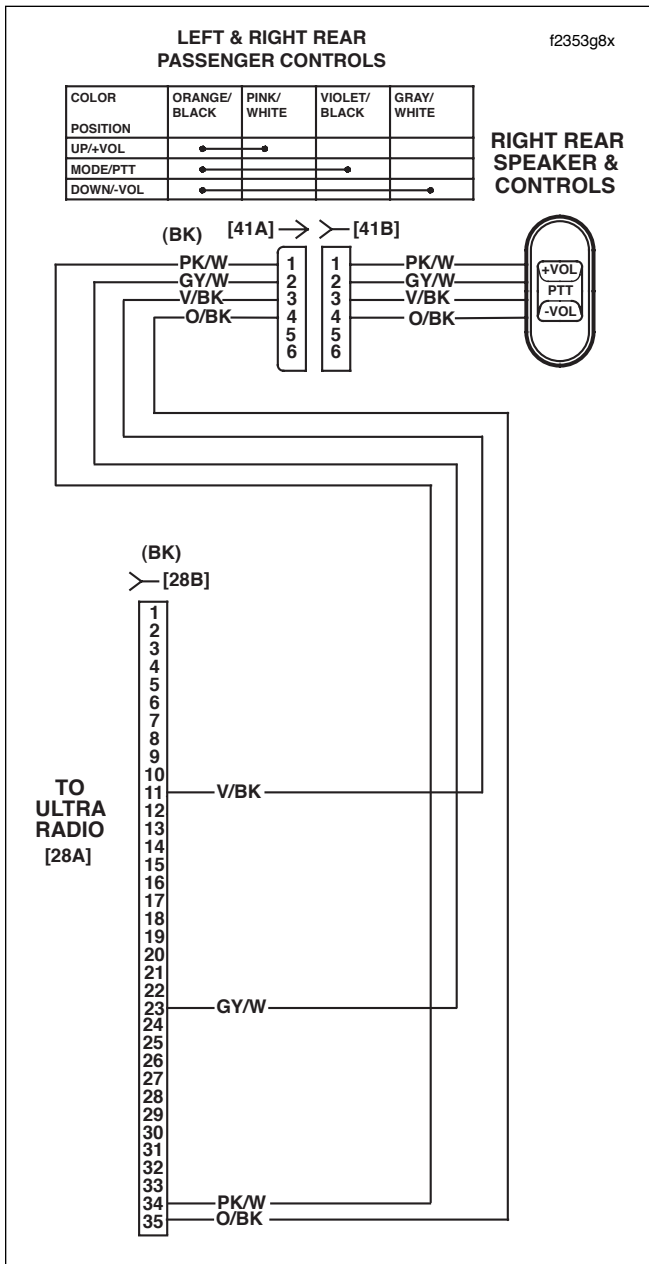

Figure 6-42. Passenger Audio/PTT Switch Circuit

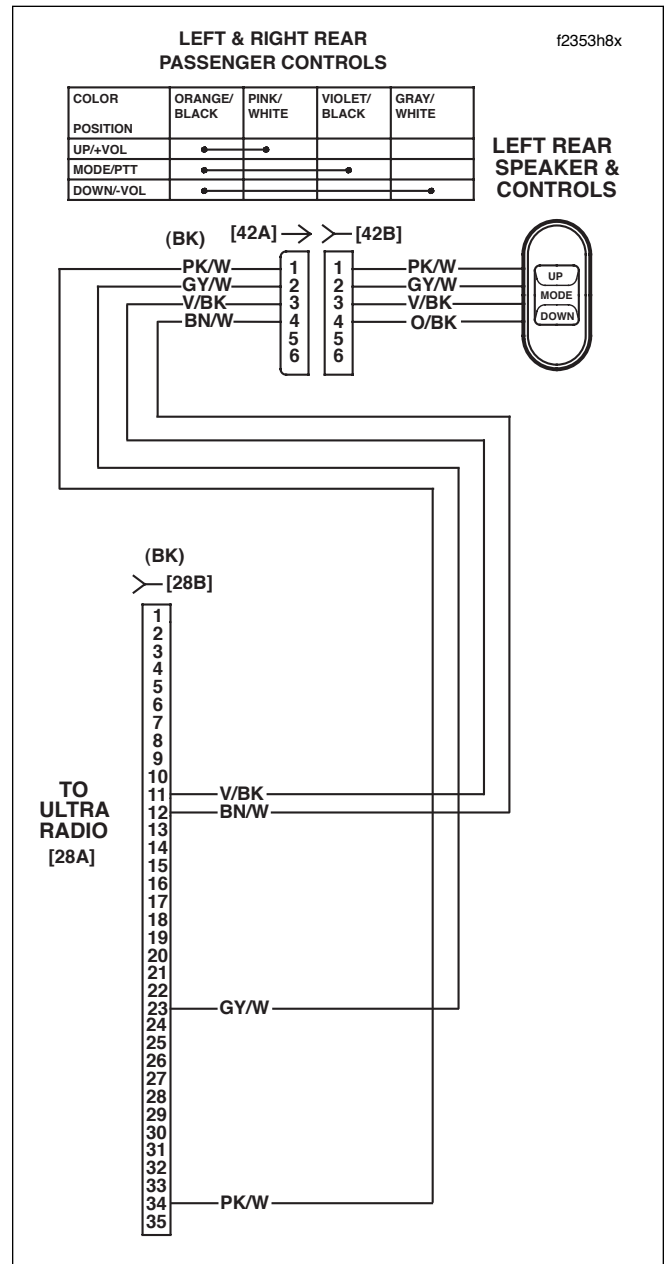

Figure 6-43. Passenger Mode Switch Circuit

Table 6-42. FLHTCU Wire Harness Connectors

NO.	DESCRIPTION	TYPE	LOCATION
[22]	Interconnect Harness to Right Handlebar Switches	12-Place Deutsch (Black)	Inner Fairing - Fork Stem Nut Lock Plate (Left Side)
[24]	Interconnect Harness to Left Handlebar Switches	12-Place Deutsch (Gray)	Inner Fairing- Left Fairing Support Brace
[27]	Radio	23-Place Amp	Inner Fairing - Back of Radio (Right Side)
[28]	Radio	35-Place Amp	Inner Fairing - Back of Radio (Left Side)
[41]	Rear Right Speaker/Passenger Controls	6-Place Mini-Deutsch	Inside Rear Right Speaker Box
[42]	Rear Left Speaker/Passenger Controls	6-Place Mini-Deutsch	Inside Rear Left Speaker Box

Test 6.5s (Part 3 of 4)

HANDLEBAR, PASSENGER OR SIDECAR SWITCHES INOPERATIVE: SYMPTOM 19

NOTE

See *Diagnostic Notes* on Page 6-61.

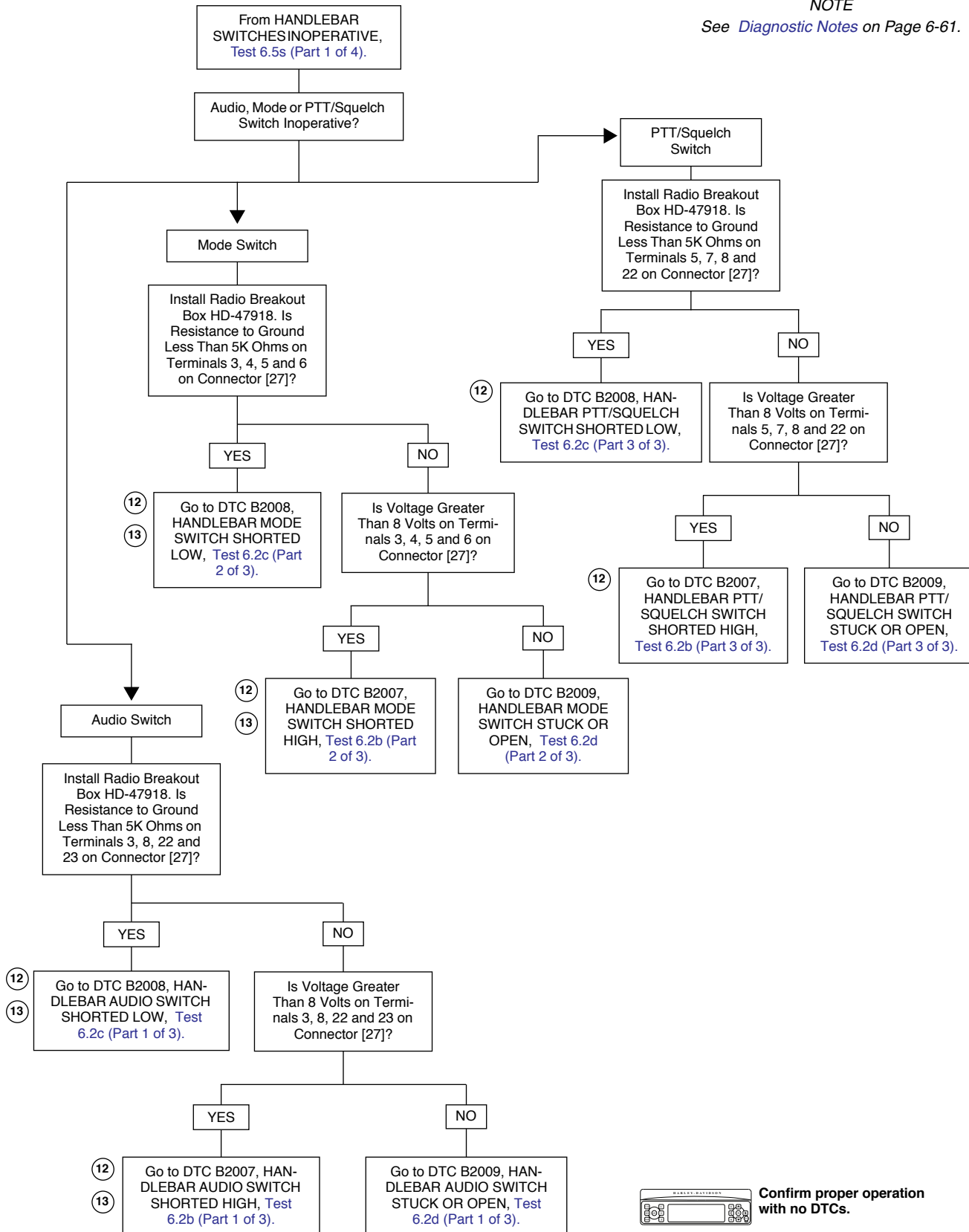

Confirm proper operation with no DTCs.

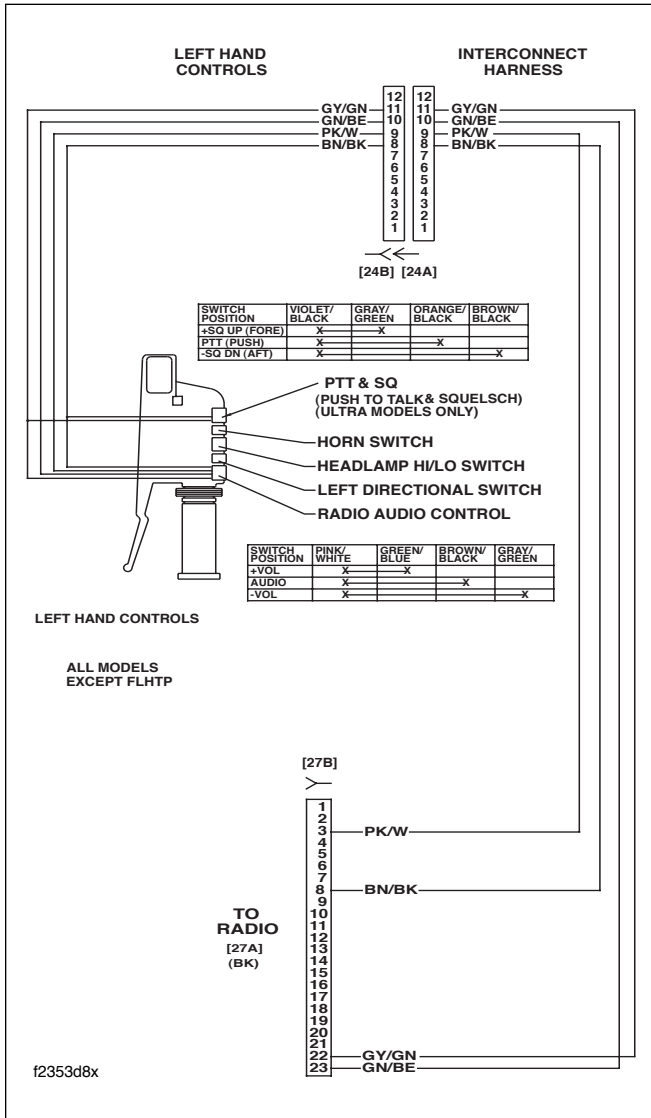

Figure 6-44. Handlebar Audio Switch Circuit

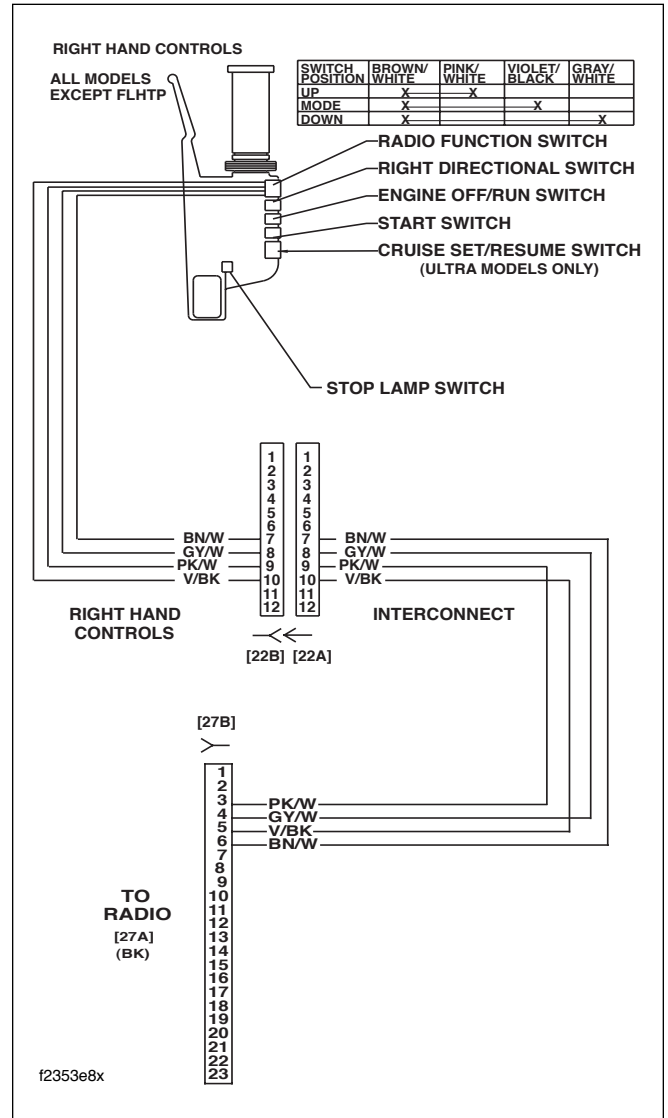

Figure 6-45. Handlebar Mode Switch Circuit

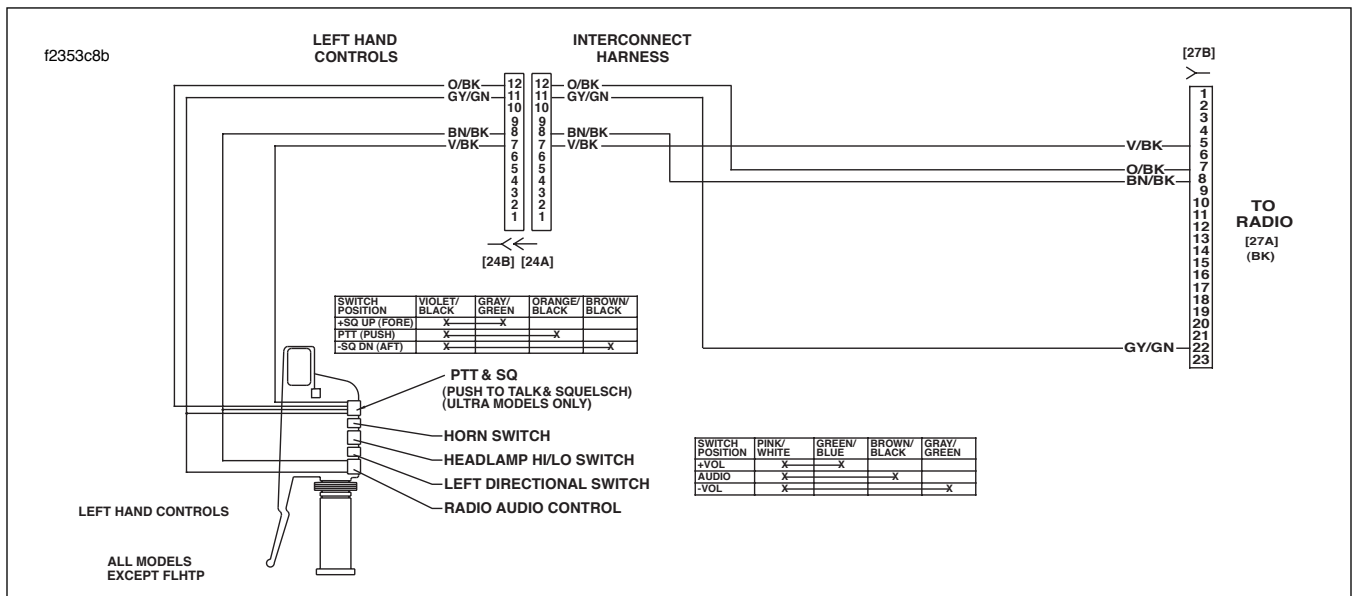

Figure 6-46. Handlebar PTT/Squelch Switch Circuit

Test 6.5s (Part 4 of 4)

HANDLEBAR, PASSENGER OR SIDECAR SWITCHES INOPERATIVE: SYMPTOM 19

④ With Key ON, Check for Voltage Between Terminals 11 (-) and 15 (+) at Breakout Box. Is Voltage Within Range for Each Function?

Sidecar Button	Minimum Voltage	Maximum Voltage
No Press	2.13	2.48
Mode	1.88	2.21
PTT	1.66	1.94
Tune (+)	1.33	1.67
Volume (+)	0.90	1.33
Tune (-)	0.55	0.89
Volume (-)	0.33	0.54

NOTE
See *Diagnostic Notes* on Page 6-61.

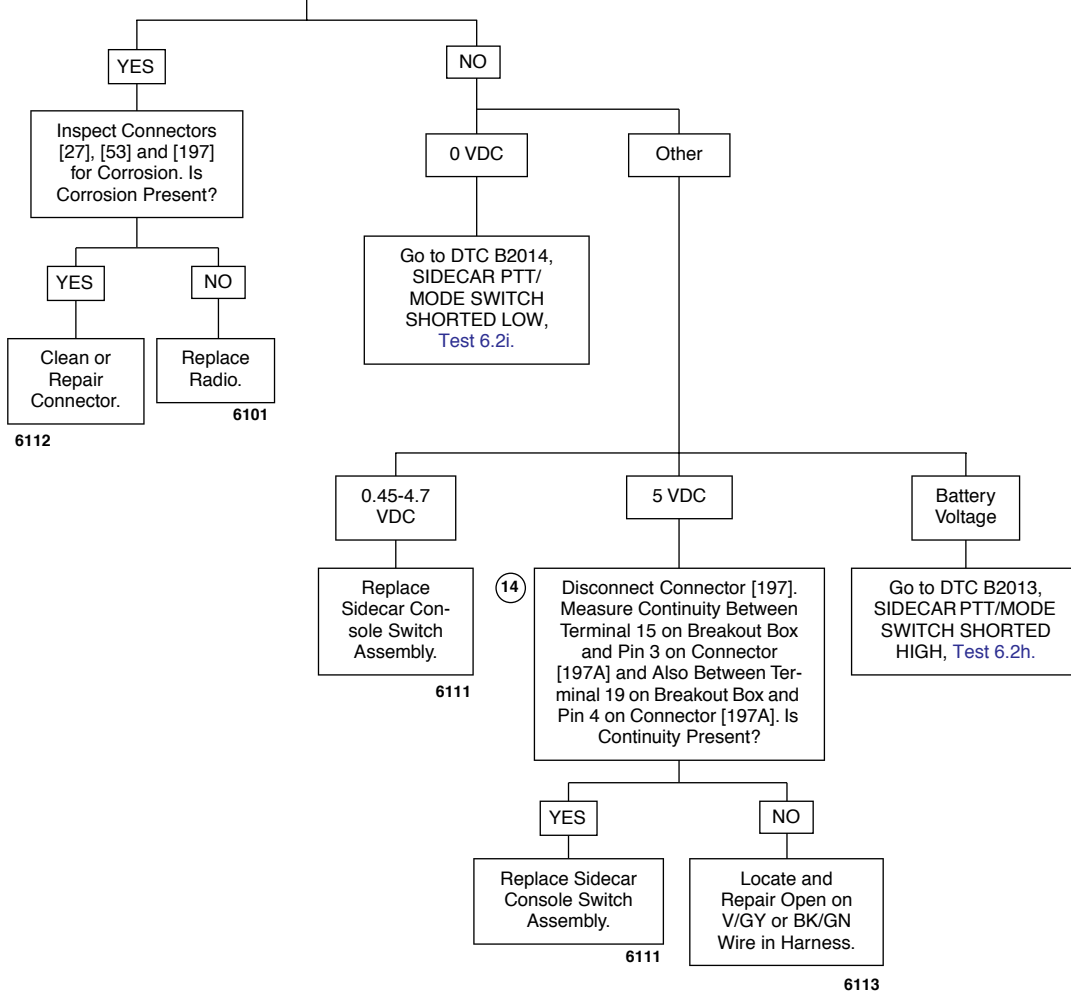

Confirm proper operation with no DTCs.

Test 6.5t

CD SKIPPING: SYMPTOM 20

NOTE
See Diagnostic Notes on Page 6-61.

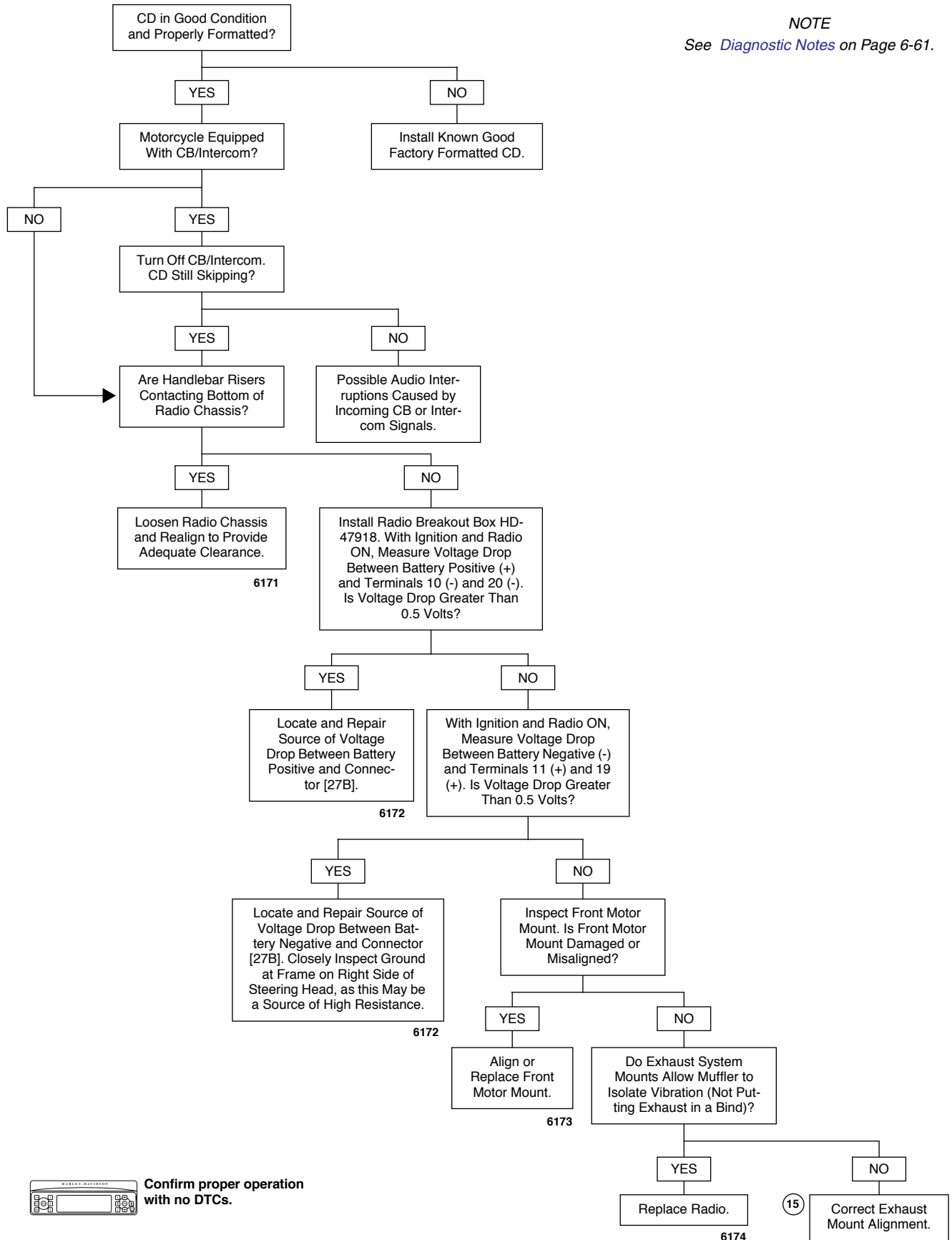

Confirm proper operation with no DTCs.

Test 6.5u (Part 1 of 5)

HANDS FREE PHONE MODULE INITIAL DIAGNOSTICS: SYMPTOM 21

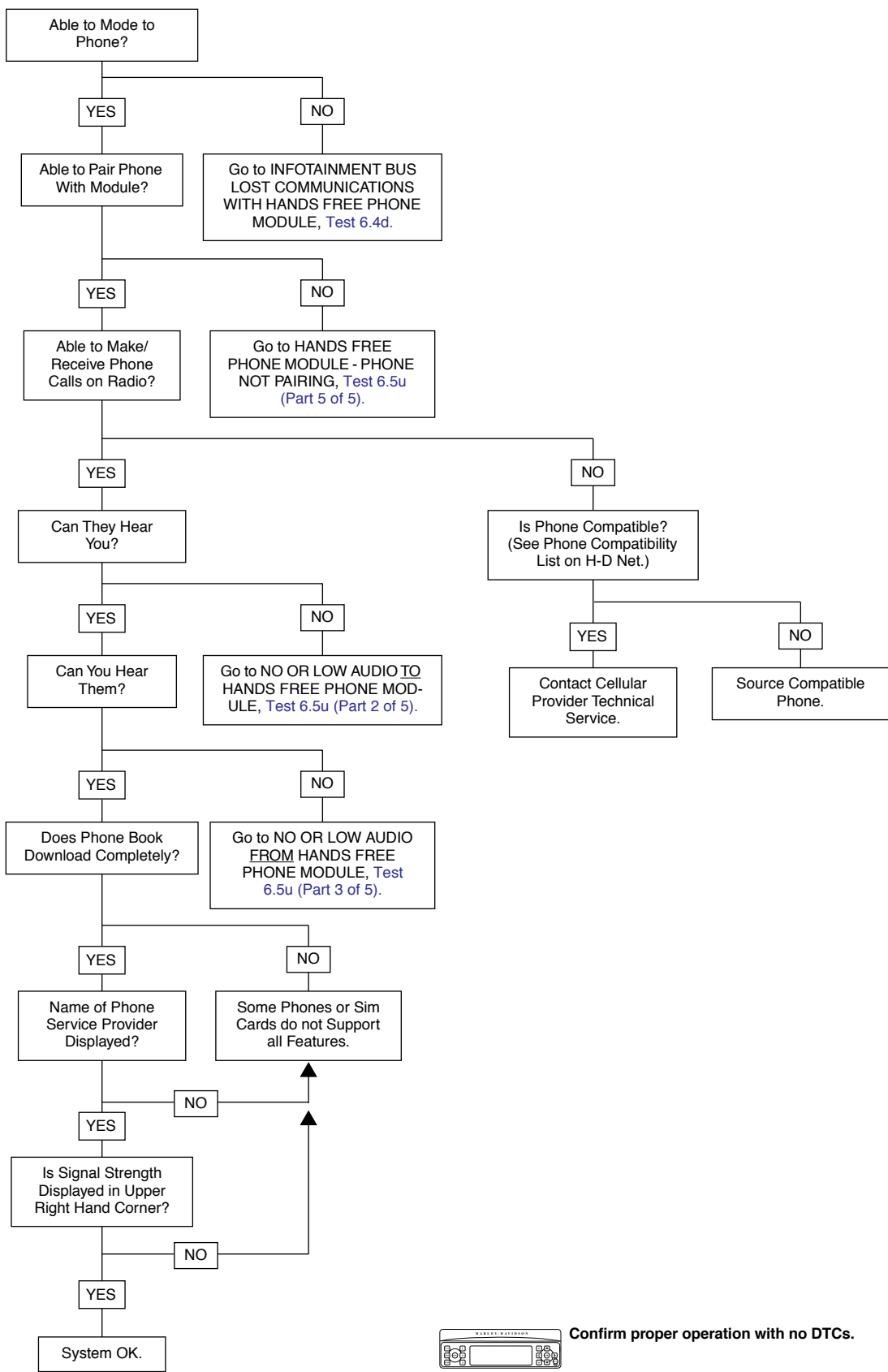

Confirm proper operation with no DTCs.

Test 6.5u (Part 2 of 5)

NO OR LOW AUDIO TO HANDS FREE PHONE MODULE: SYMPTOM 21

NOTE
See *Diagnostic Notes* on Page 6-61.

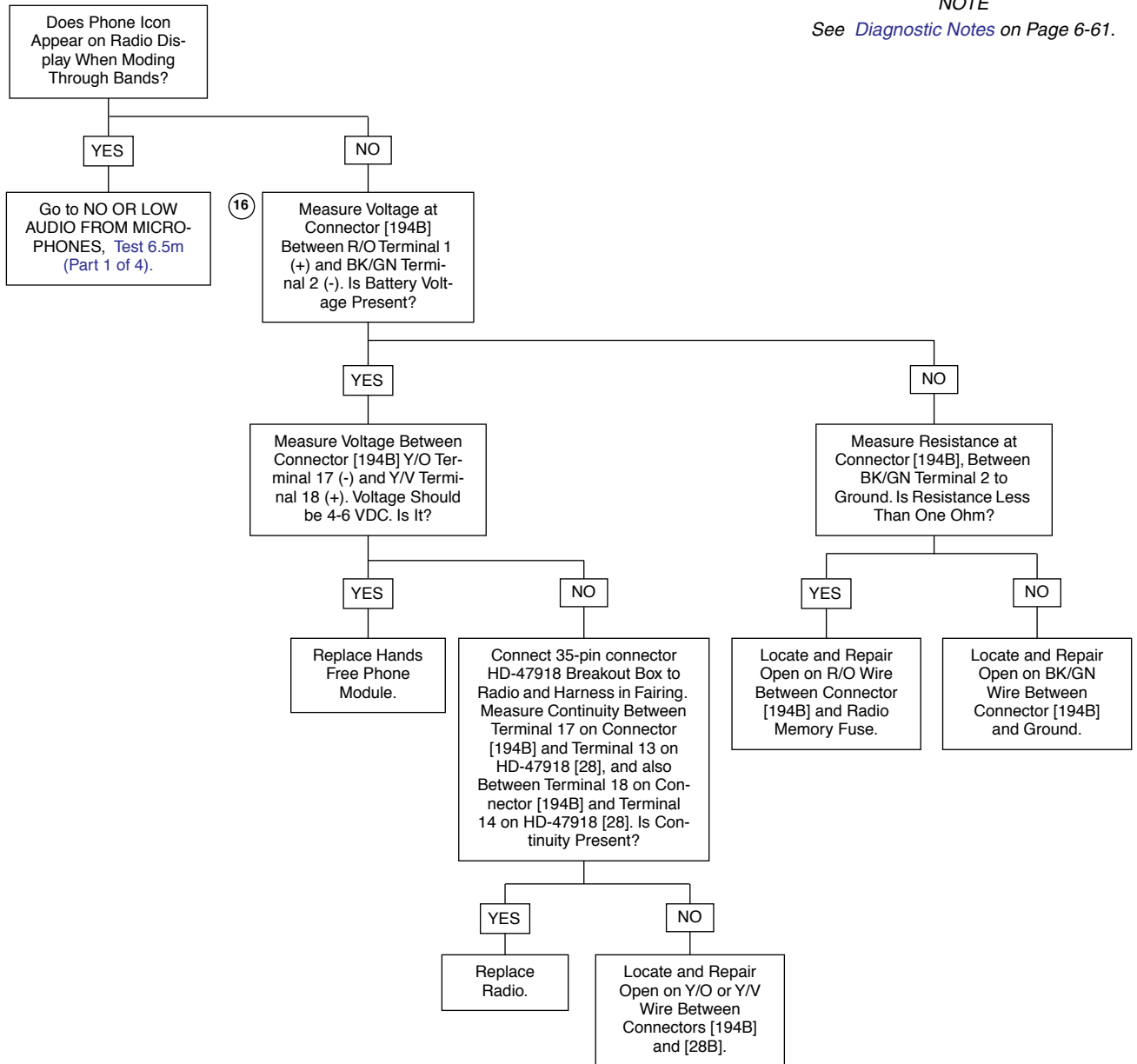

Confirm proper operation with no DTCs.

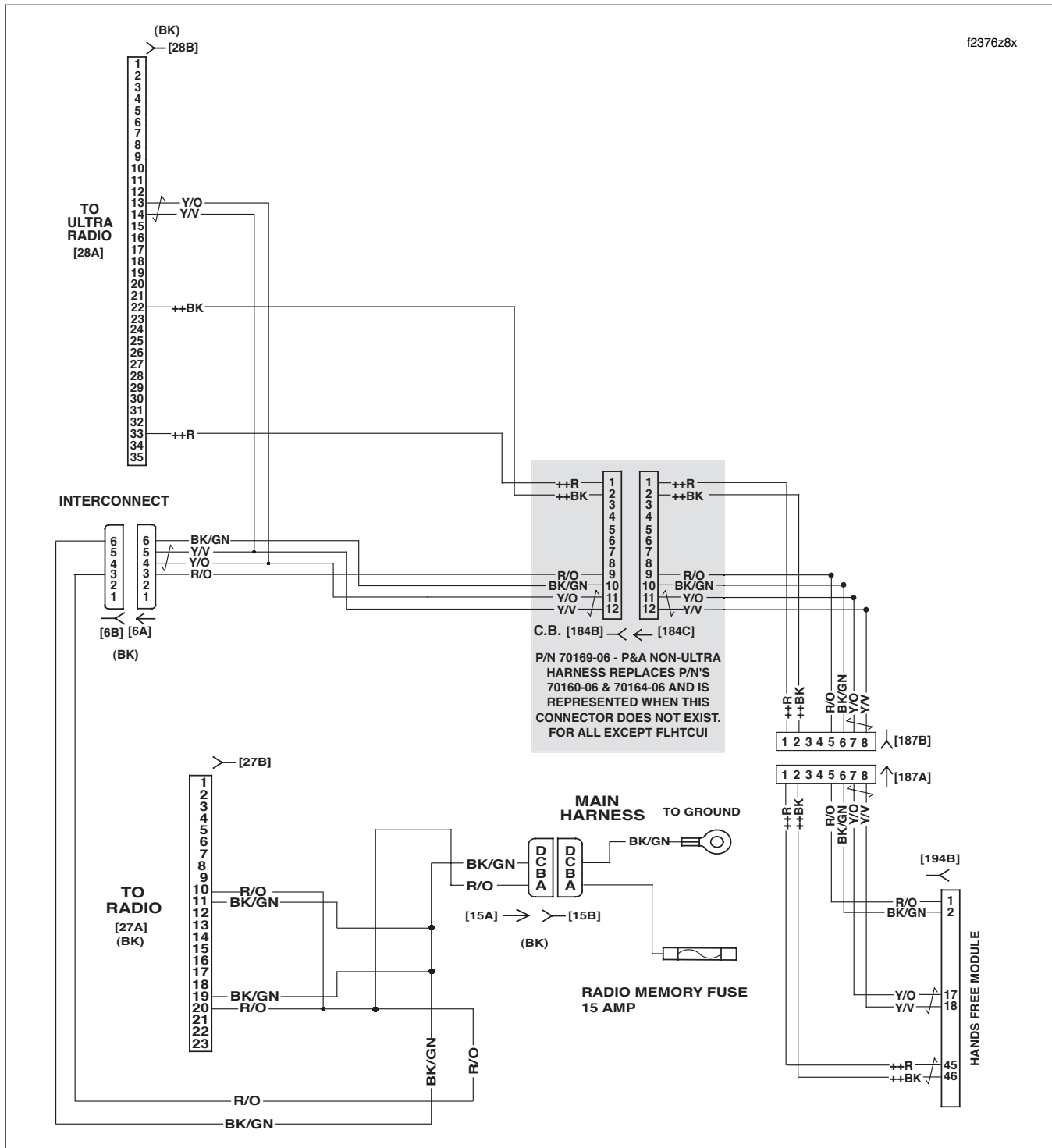

Figure 6-47. Hands Free Phone Circuit

Table 6-43. FLHTCU Wire Harness Connectors

NO.	DESCRIPTION	TYPE	LOCATION
[6]	Audio to Interconnect Harness	6-Place Deutsch (Black)	Inner Fairing - Top of Radio (Left Side)
[15]	Main to Interconnect Harness	4-Place Packard	Inner Fairing - Right Fairing Bracket
[27]	Radio	23-Place Amp	Inner Fairing - Back of Radio (Right Side)
[28]	Radio	35-Place Amp	Inner Fairing - Back of Radio (Left Side)
[187]	Hands Free Phone Module	12-Place Mini-Deutsch	Inner Fairing - Top of Radio (Left Side)
[194]	Hands Free Phone Module	54-Place Amp	Inside Tour-Pak (Left Side)

Test 6.5u (Part 3 of 5)

NO OR LOW AUDIO FROM HANDS FREE PHONE MODULE: SYMPTOM 21

NOTE
See *Diagnostic Notes* on Page 6-61.

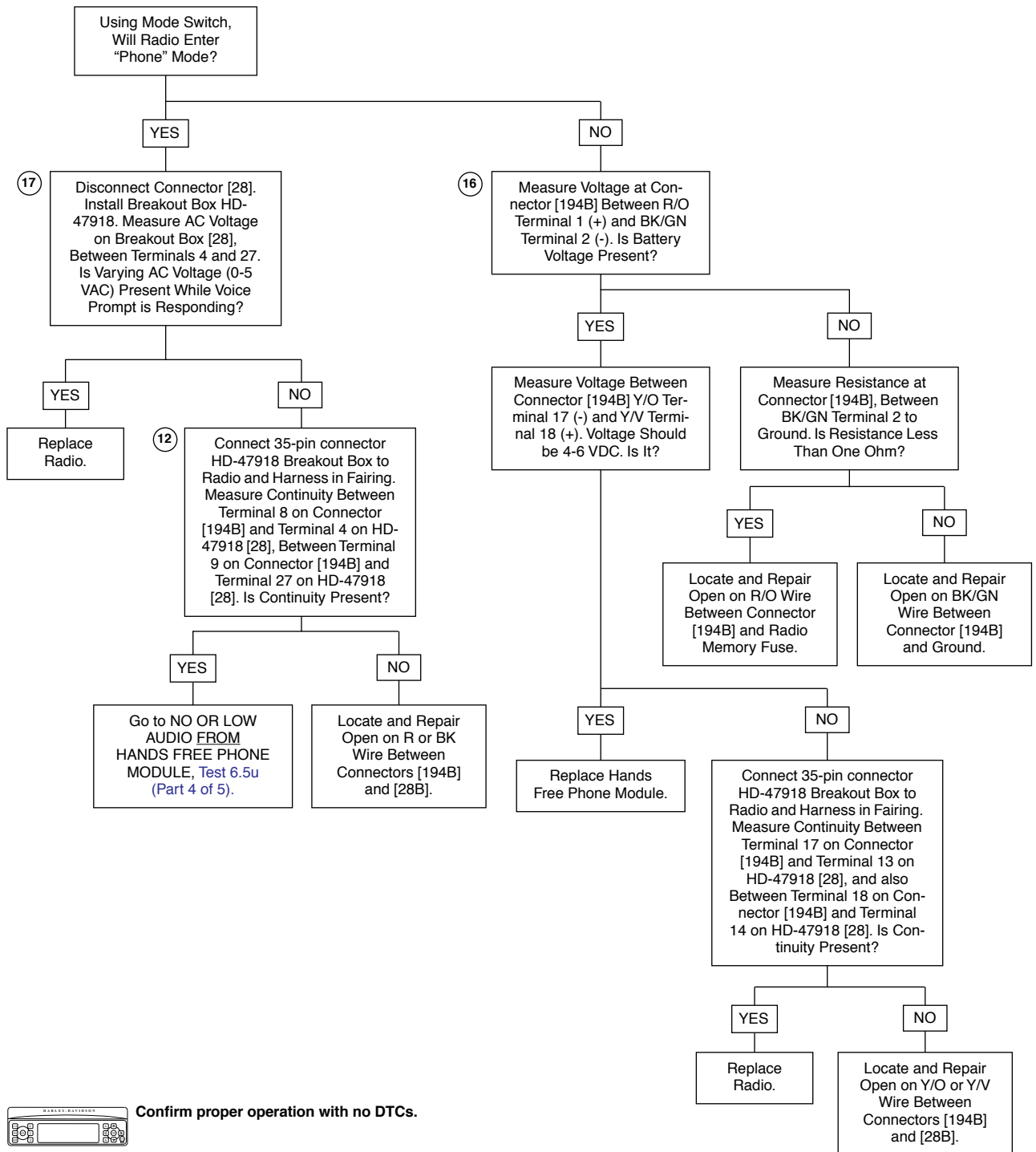

Confirm proper operation with no DTCs.

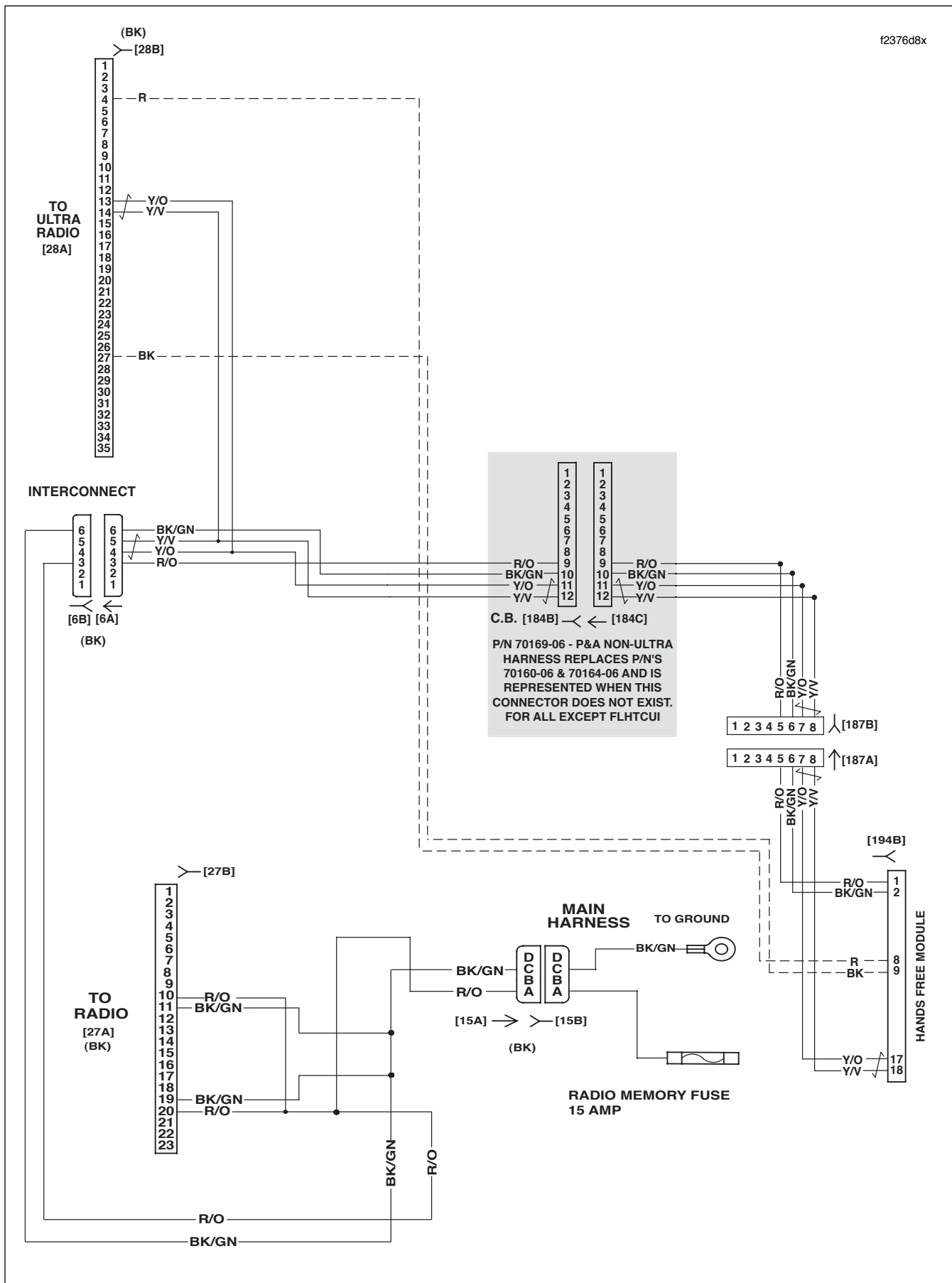
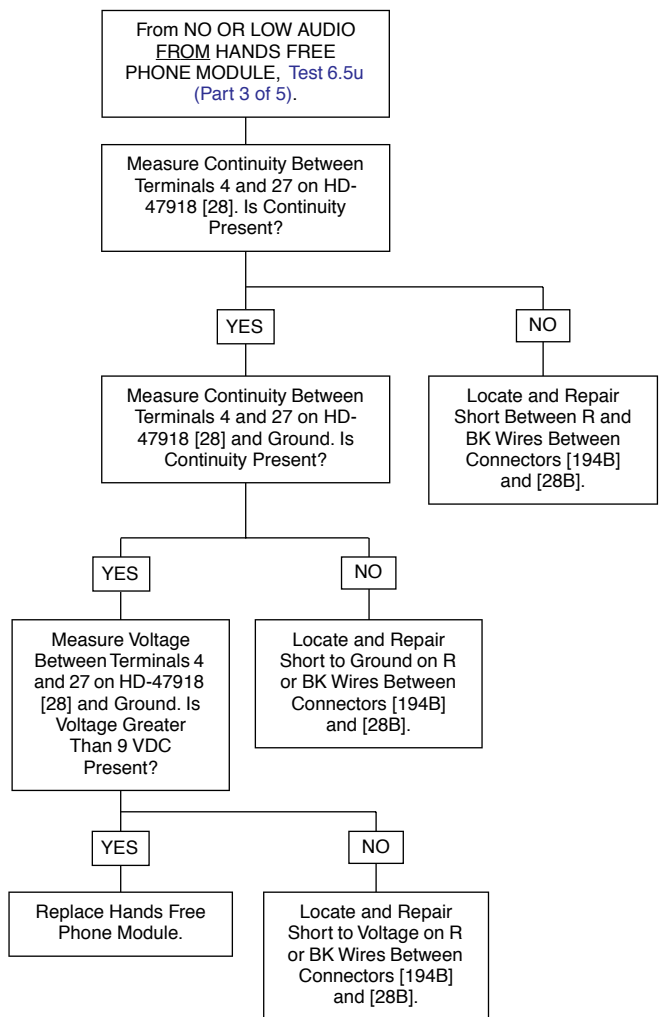

Figure 6-48. Hands Free Phone Circuit

Test 6.5u (Part 4 of 5)

NO OR LOW AUDIO FROM HANDS FREE PHONE MODULE: SYMPTOM 21



Confirm proper operation with no DTCs.

Table 6-44. FLHTCU Wire Harness Connectors

NO.	DESCRIPTION	TYPE	LOCATION
[6]	Audio to Interconnect Harness	6-Place Deutsch (Black)	Inner Fairing - Top of Radio (Left Side)
[15]	Main to Interconnect Harness	4-Place Packard	Inner Fairing - Right Fairing Bracket
[27]	Radio	23-Place Amp	Inner Fairing - Back of Radio (Right Side)
[28]	Radio	35-Place Amp	Inner Fairing - Back of Radio (Left Side)
[187]	Hands Free Phone Module	12-Place Mini-Deutsch	Inner Fairing - Top of Radio (Left Side)
[194]	Hands Free Phone Module	54-Place Amp	Inside Tour-Pak (Left Side)

Test 6.5u (Part 5 of 5)

HANDS FREE PHONE MODULE - PHONE NOT PAIRING: SYMPTOM 21

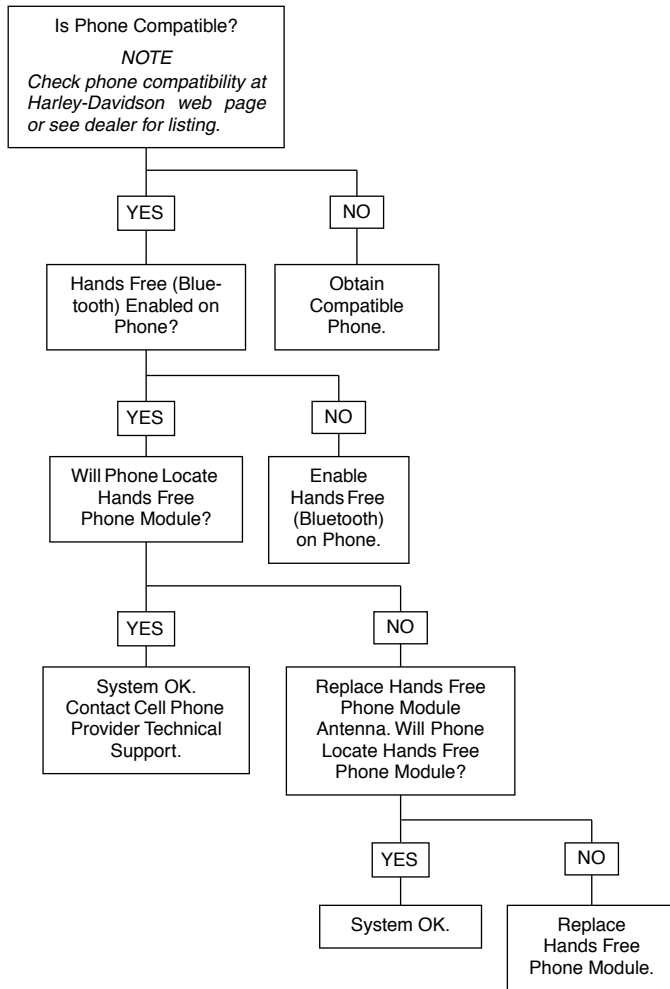

Confirm proper operation with no DTCs.