

TWIN CAM DAMPER SPRING DETAIL

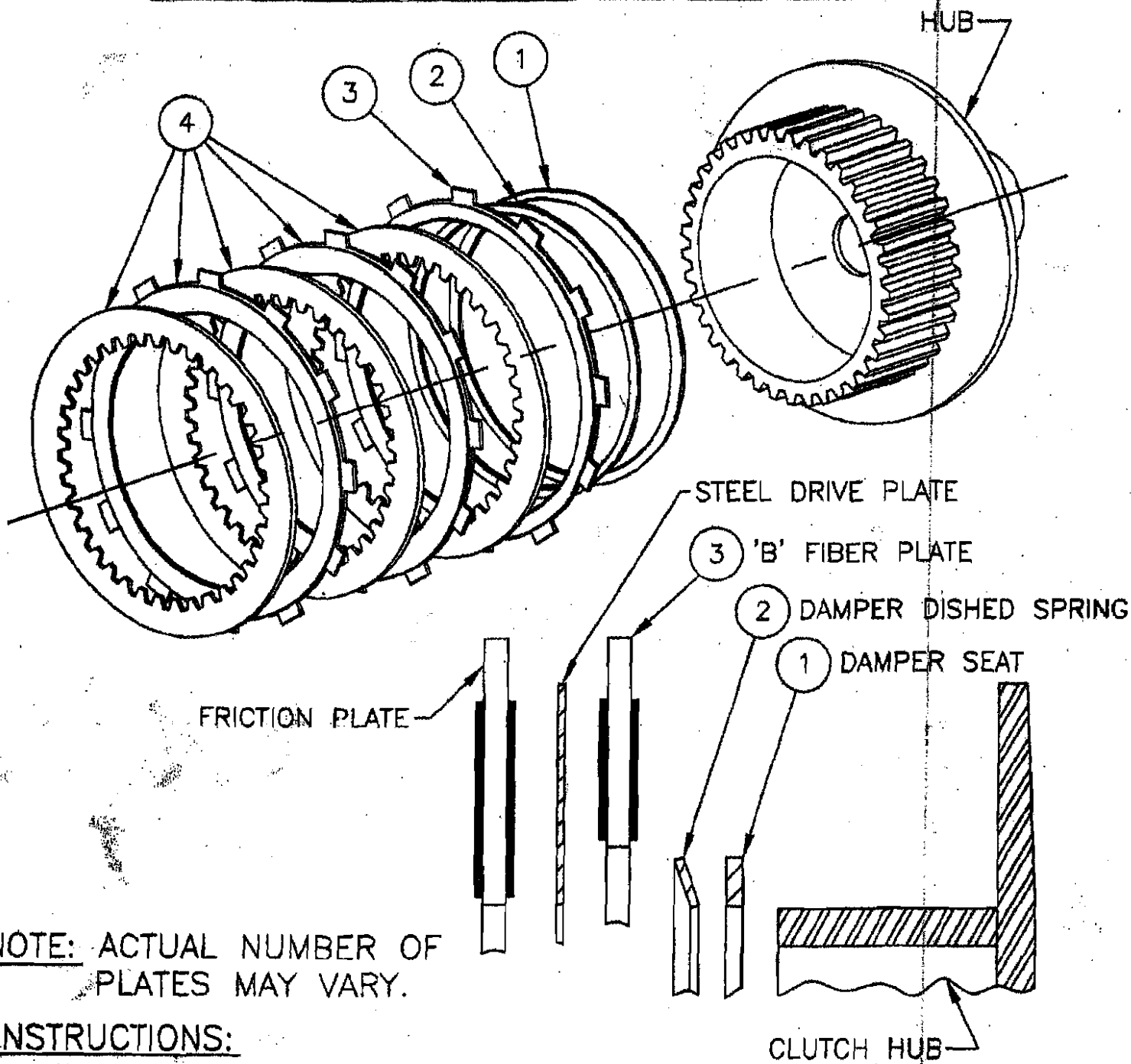

NOTE: ACTUAL NUMBER OF PLATES MAY VARY.

INSTRUCTIONS:

1. INSTALL SMALL FLAT STEEL SEAT RING IN UNIT.
2. INSTALL DAMPER DISHED SPRING WITH DISH FACING OUT.
3. INSTALL 'B' FIBER PLATE. ('B' PLATE HAS LARGER CENTER HOLE)
4. INSTALL A STEEL DRIVE PLATE FOLLOWED BY A FRICTION PLATE. USE THIS PATTERN TO COMPLETE INSTALLATION OF PLATES.
5. INSTALL PRESSURE PLATE AND SPRING(S).
6. RE-USE OEM DAMPER SEAT & SPRING.

BY
Barnett