



# INSTRUCTIONS

-J03831

2009-08-11

## 180 MM WIDE TIRE KIT

### GENERAL

#### Kit Number

43768-06

#### Models

For model fitment information, see the P&A Retail Catalog or the Parts and Accessories section of [www.harley-davidson.com](http://www.harley-davidson.com) (English only).

This kit will fit models equipped with the following:

- Saddlebag Kits
- Detachable Sideplate Kit only when installed with a Saddlebag Kit.

#### Additional Parts Required

A Dunlop® tire **must be purchased** for the front wheel when using the wide tire kit on the 2010 model year Dyna.

Motorcycles equipped with laced wheels also require inner tube (40502-06) and tire rim flap (43101-06) for proper installation.

Proper installation of this kit requires the use of Loctite® 243 Threadlocker and Sealant - Blue (99642-97).

#### ⚠ WARNING

**Dealer installation is required. Proper installation of this kit requires specific alignment procedures to ensure proper tire clearance. Tire contact with chassis components can lead to tire failure, which could result in death or serious injury. (00428c)**

#### NOTE

*This instruction sheet references Service Manual information. A Service Manual for your model motorcycle is required for this installation.*

#### Kit Contents

See Figure 9 and Table 1.

### INSTALLATION

#### Install Wide Tire

1. Place motorcycle on a lift and secure front tire.
2. Place a scissor jack under the frame so that the rear wheel can be raised and lowered.

#### ⚠ WARNING

**To prevent accidental vehicle start-up, which could cause death or serious injury, disconnect negative (-) battery cable before proceeding. (00048a)**

3. Disconnect battery negative (-) cable.

#### NOTE

**If a Dyna Saddlebag Kit has been previously installed, proceed to Step 16. Discard rear fender brackets, screws and cable straps from the 180 MM Wide Tire Kit.**

**If Dyna Saddlebag Kit is being simultaneously installed, install the saddlebags according to the Instruction Sheet included with that kit, then proceed to Step 16. Discard rear fender brackets, screws and cable straps from the 180 MM Wide Tire Kit.**

4. Refer to the appropriate Service Manual and remove the rear wheel.

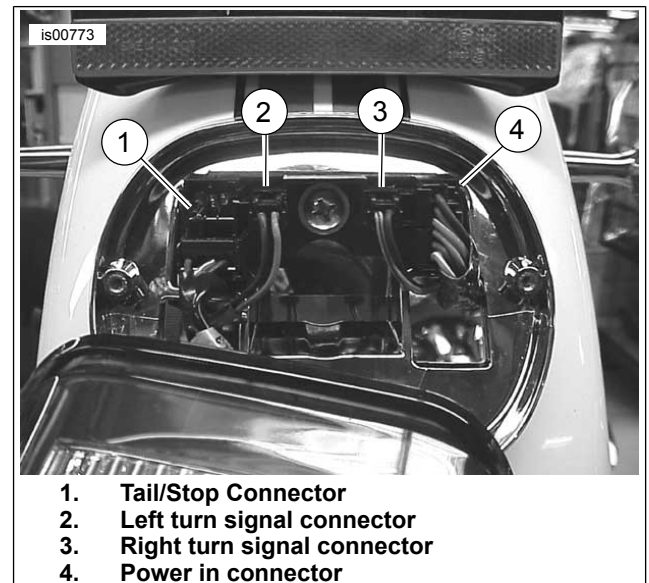
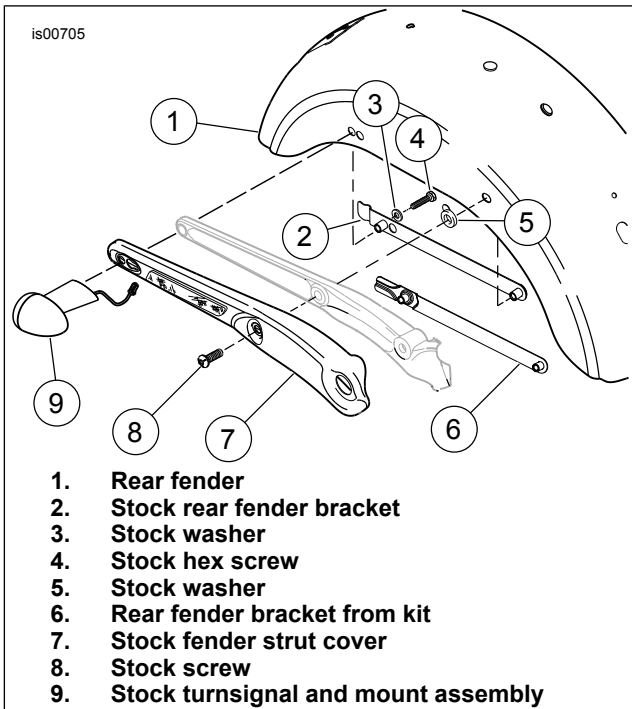

Figure 1. Remove Connectors



**Figure 2. Replace rear fender bracket**

5. See Figure 1. Remove two screws and tail light lens from the tail light base. Disconnect the tail light connector (1) and set the tail light aside.

**NOTE**

See Figure 2 for Steps 7-10.

6. See Figure 1. Disconnect the turn signal connectors (2 and 3) and power in connector (4).

**NOTE**

The washer (5) between the fender strut and fender is held in place with an adhesive. Do not remove.

7. Remove screw (4) and washer (3) from inside of the fender (1) and remove the rear turn signal and mount assembly (9).
8. Remove screw (8) and stock rear fender bracket (2). Save the screw, and discard rear fender bracket.
9. Install rear fender bracket from kit (6) loosely with screw (8) from previous step.

**NOTE**

See Figure 3. **Keep the turn signal wire flat to the fender to ensure the bracket seats properly against the fender.**

See Figure 4. **Ensure loop of the wire (1) that routes around the turn signal mounting screw and bracket stud is a maximum of 3/8 in. below the bottom of the rear fender bracket (4).**

10. See Figure 9. Apply 2-3 drops of Loctite 243 (blue) to the screw (3) from the kit, route the turn signal wire into the fender and loosely install turn signal using the screw.

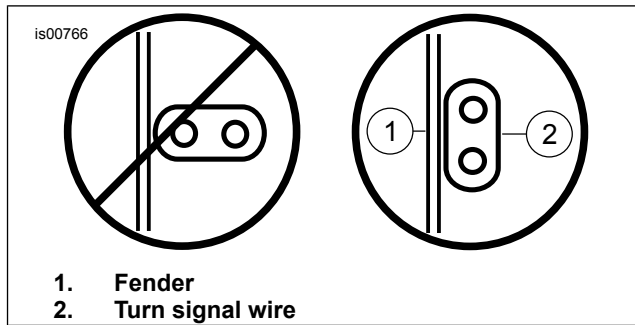

**Figure 3. Keep Turn Signal Wire Flat To Rear Fender Wall**

11. See Figure 4. Route turn signal wire down around the fender bracket stud, through the channel (3), towards the rear of the motorcycle. Ensure that the wire is flat to the fender in the channel. Continue to route the wire, flat against the fender, up to the rear of the wire clip as shown, then rearward to the tail light.
12. See Figure 4. Tighten turn signal mounting screw (5) to 19 N·m (14 ft-lbs).

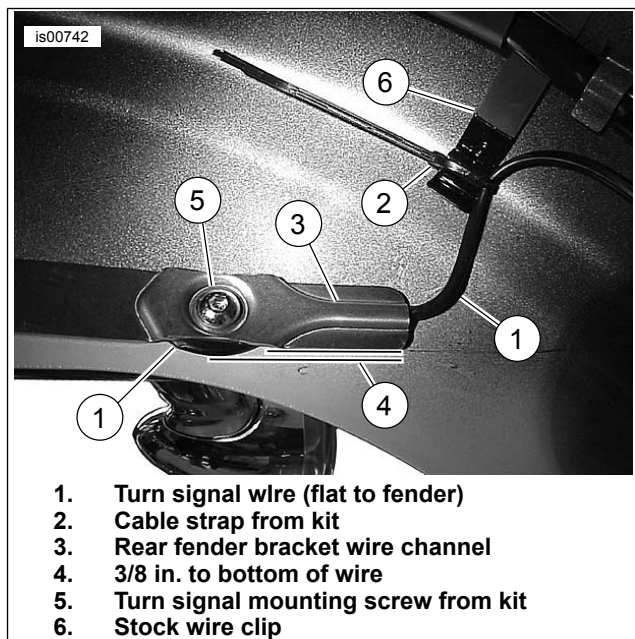

**Figure 4. Turn Signal Wire Routing**

13. See Figure 2. Tighten fender strut cover screw (8) to 24 N·m (18 ft-lbs).
14. See Figure 4. Secure the turn signal wire (1) to the rear of wire clip (6) using a cable strap (2) as shown. Ensure the clasp of the cable strap locates in front of (forward of) the wire clip as shown. Cut off excess cable strap.
15. Repeat Steps 7-15 for the opposite side of the motorcycle.
16. See the appropriate Service Manual and remove the rear tire from the wheel and replace with the tire from the kit. Also, inspect the tire, check radial and lateral runout, and balance the wheel.
17. See the appropriate Service Manual. Install the rear wheel and verify axle/swing arm alignment and belt deflection.

## Clearance Check

1. Remove upper shock bolts and spacers from both sides of the motorcyles.
2. Using the jack, lower the motorcycle until the rear fender strut almost rests on the belt guard.
3. Obtain a 24 in. length of straight, cold drawn, 3/16 in. round bar or square bar to use as a gauge.
4. See Figure 5. Lay gauge across the tire's radial ridge (2) and check that the gauge (1) can pass through the fender without touching the turn signal mounting screw or the rear fender bracket. Repeat for opposite side of motorcycle.
5. **If gauge passes**, proceed to the Return Motorcycle to Service section below. **If gauge contacts screw or bracket**, perform the Horizontal Adjustment procedure below.

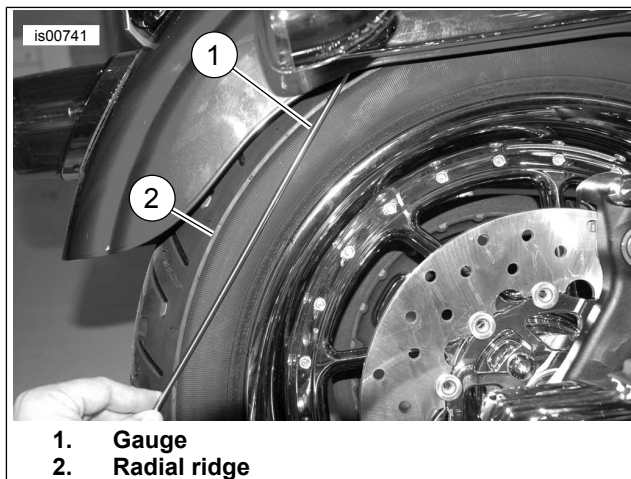

Figure 5. Gauge Clearance

## Horizontal Adjustment

The following adjustment procedure is meant to center the tire between the rear fender brackets. It requires two people.

1. See Figure 8. Loosen the two front (5) and two rear (1) mount bolts.

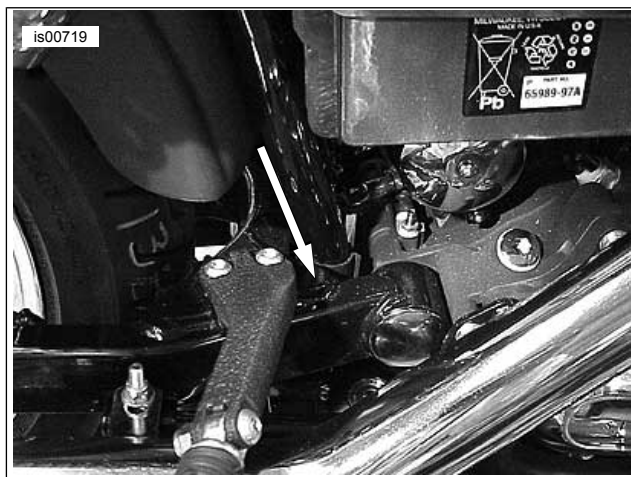

Figure 6. Rear Leverage Points (Right Side Shown, Left Side Similar)

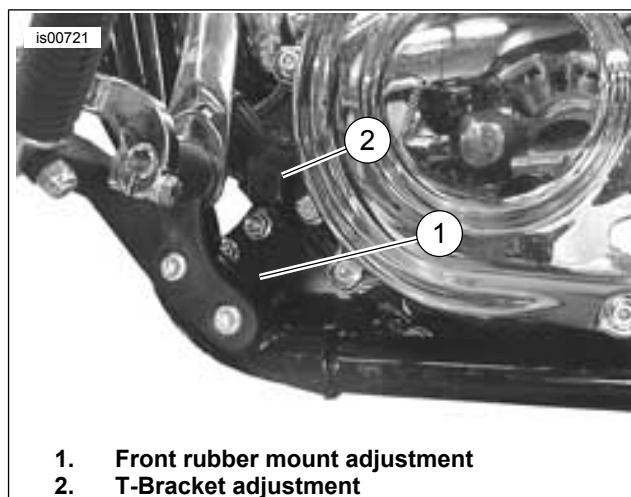

Figure 7. Front Leverage Points (Left Side Shown, Right Side Similar)

2. See Figure 6. Using a suitable tool wrapped in a clean, soft cloth, between the swingarm and frame, as indicated by the arrow, move the rear wheel to the left or right, as necessary, to provide clearance for the gauge. Tighten the rear mount bolts while maintaining pressure on the tool. Tighten bolts to 30–37 N·m (22–27 ft-lbs).
3. See Figure 7. Using a suitable tool wrapped in a clean, soft cloth, between the front mount and frame (1), move the rear wheel to the left or right, as necessary, to provide clearance for the gauge. Tighten the front mount bolts while maintaining pressure on the tool. Tighten bolts to 30–37 N·m (22–27 ft-lbs).
4. Repeat Clearance Check procedure. If further adjustment is necessary, proceed with the following step. If further adjustment is not necessary, proceed to RETURN MOTORCYCLE TO SERVICE section.
5. See Figure 8. Loosen the two top bolts (3) of the T-bracket (4).
6. See Figure 7. Use a suitable tool between the frame and T-bracket (2). Move the rear wheel to the left or right, as necessary, to provide clearance for the gauge. Tighten the T-bracket bolts while maintaining pressure on the tool. Tighten bolts to 34–41 N·m (25–30 ft-lbs).
7. Repeat Clearance Check procedure.

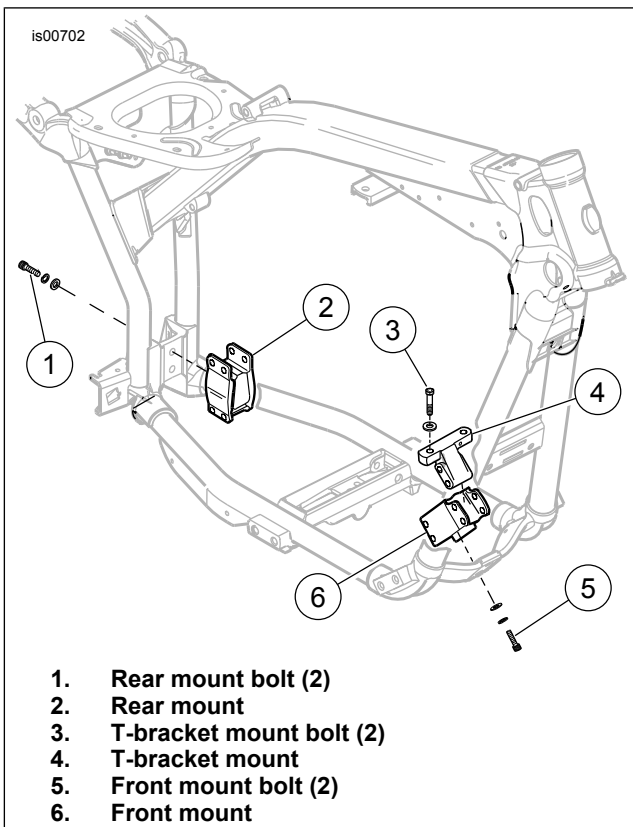

Figure 8. Vehicle Alignment

## Return Motorcycle to Service

1. Apply 2-3 drops of Loctite 243 (blue) to the upper shock bolts. Install upper shock bolts and spacers. Tighten upper shock bolts to 102–115 N·m (75–85 ft-lbs).
2. See Figure 1. Connect turn signals connectors (2 and 3), power in connector (4), and tail light connector (1). Route wires as shown.
3. Install tail light to rear fender using two tail light mounting screws removed previously.
4. Connect battery negative (-) cable.

### ▲ WARNING

Be sure that all lights and switches operate properly before operating motorcycle. Low visibility of rider can result in death or serious injury. (00316a)

5. Verify turn signal, brake and tail light operation.
6. See the appropriate Service Manual and perform the Vehicle Alignment procedure and verify rear wheel to front wheel parallelism.
7. Verify that belt and belt guard are clear of the rear tire.
8. To prevent excessive vibration, check for loose hardware and re-tighten as necessary.

## SERVICE PARTS

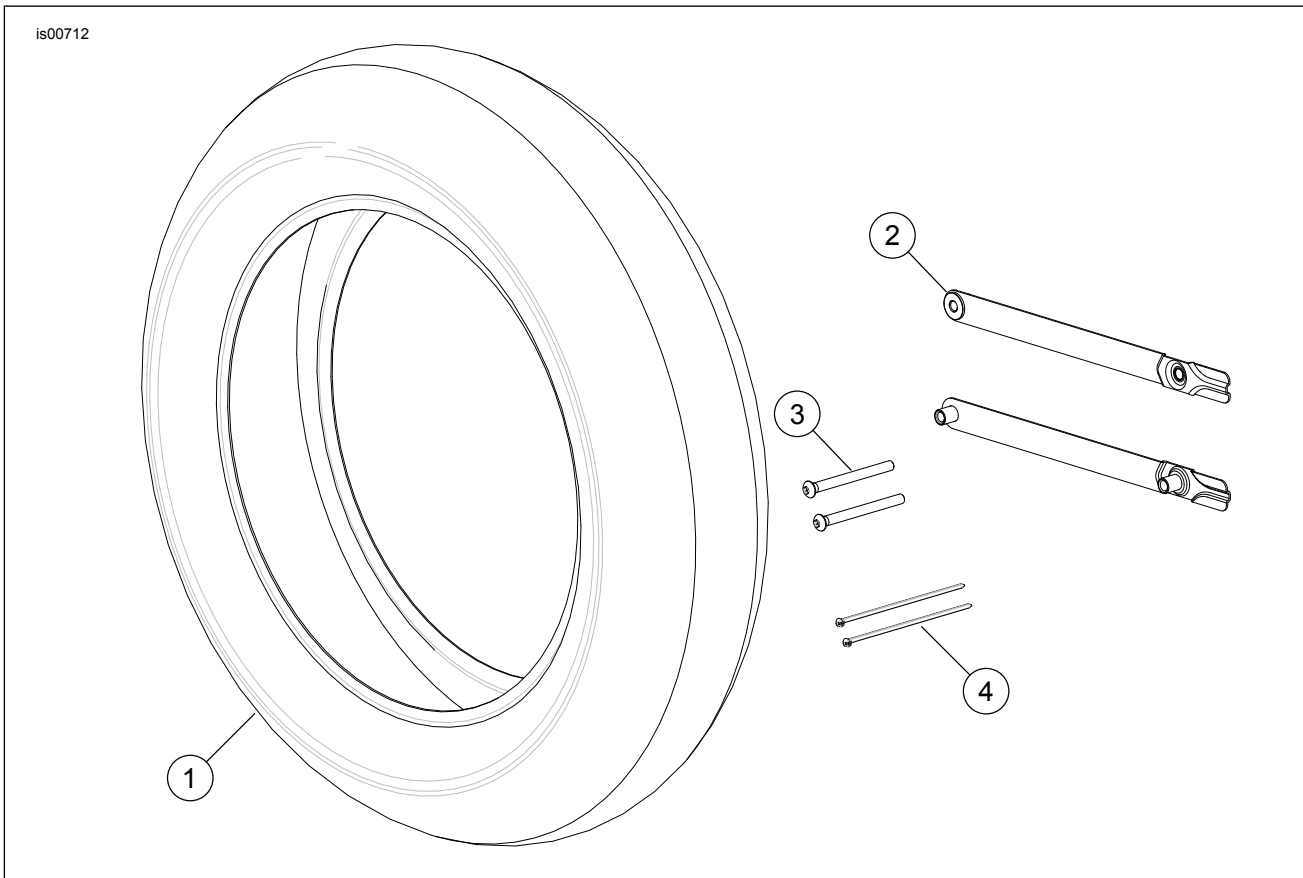

Figure 9. Service Parts for Wide Tire Kit

**Table 1. Service Parts Table**

<b>Item</b>	<b>Description (Quantity)</b>	<b>Part Number</b>
1	Tire, 180/60-B17 75V	43197-04A
2	Bracket, rear fender (2)	59514-06
3	Screw (2)	4592
4	Cable strap (2)	10065